



Emission Certified Stationary Engine Fuel and Control System Diagnostic Service Manual

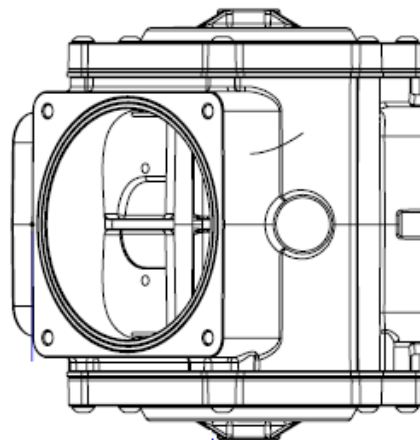
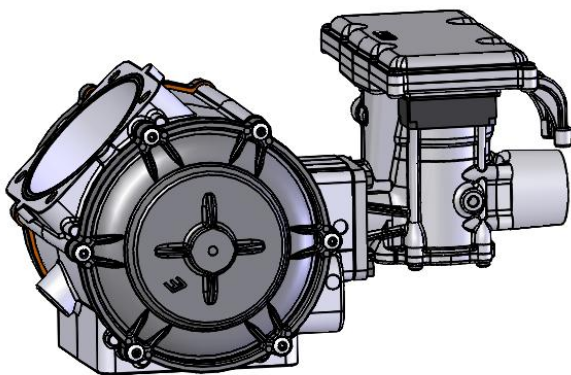

Table of Contents

| | |
|--|------------|
| General Information | 3 |
| <i>An overview of this Service Manual</i> | |
| Maintenance | 6 |
| <i>General maintenance and maintenance interval information</i> | |
| Fuel System | 14 |
| <i>An overview of the fuel system and its components</i> | |
| Fuel System Diagnosis | 21 |
| <i>How to identify a general problem</i> | |
| Symptom Diagnostics | 29 |
| <i>How to correct a specific problem</i> | |
| Electrical Section | 42 |
| Diagnostic Scan Tool | 47 |
| <i>Using the DST for testing and trouble shooting</i> | |
| Engine Wire Harness Repair | 69 |
| <i>Repairing a wire harness on the vehicle</i> | |
| Diagnostic Trouble Codes (DTCs) | 73 |
| <i>Application, schematic and DTC specific code information</i> | |
| Definitions | 231 |
| <i>Definitions of phrases and acronyms used throughout this Service Manual</i> | |

General Information

GENERAL INFORMATION

INTRODUCTION

This service manual has been developed to provide the service technician with the basic understanding of the NGE certified fuel and emission systems for their NGE engine line. This manual should be used in conjunction with the base engine manual and the OEM service manual when diagnosing fuel or electrical problems.

SERVICING YOUR EMISSIONS CERTIFIED ENGINE

Any maintenance and repair should be performed by trained and experienced service technicians. Proper tools and equipment should be used to prevent injury to the servicing technician and damage to the vehicle or components. Service repairs should always be performed in a safe environment and the technician should always wear protective clothing to prevent injury.

FUEL QUALITY

NGE engines are designed to operate on pipeline quality natural gas with a heat value of 1050 BTU or higher. LPG engines and fuel systems are designed to operate on HD-5 or HD-10 specification LPG fuel. Fuel other than HD-5 or HD-10 may cause harm to the engine's emission control system and a warranty claim may be denied on this basis if operators can readily find the proper fuel. Use of any other fuel may result in your engine no longer operating in compliance with CARB or EPA emissions requirements.

FUEL SYSTEM CAUTIONS



CAUTION

Do not smoke, carry lighted tobacco or use a lighted flame of any type when working on or near any fuel related component. Highly flammable air-fuel mixtures may be present and can be ignited causing personal injury



CAUTION

Do not allow LPG to contact the skin. LPG is stored in the fuel tank as a liquid. When LPG contacts the atmosphere, it immediately expands into a gas, resulting in a refrigeration effect that can cause severe burns to the skin.



CAUTION

Do not allow LPG to accumulate in areas below ground level such as in a service pit or underground ventilation systems. LPG is heavier than air and can displace oxygen, creating a dangerous condition



CAUTION

Do not make repairs to the LPG fuel system if you are not familiar with or trained to service LPG fuel system. Contact the dealer who sold you the vehicle to locate a repair facility with trained technicians to repair your fuel system

WARNINGS, CAUTIONS AND NOTES

This manual contains several different Warnings, Cautions, and Notes that must be observed to prevent personal injury and or damage to the vehicle, the fuel system or personal property.

A "WARNING" is an advisement that by performing a process or procedure listed in this manual improperly may result in serious bodily injury, death and/or serious damage to the vehicle or property.

PROPER USE OF THIS SERVICE MANUAL, TOOLS AND EQUIPMENT

To reduce the potential for injury to the technician or others and to reduce damage to the equipment during service repairs the technician should observe the following steps:

- The service procedures defined in this manual, when followed, have been found to be a safe and efficient process to repair the fuel system. In some cases special tools may be required to perform the necessary procedures to safely remove and replace a failed component.
- The installed NGE fuel system has been certified with the Environmental Protection Agency (EPA) and complies with the regulation in effect at the time of certification. When servicing the fuel and emission control system you should follow all the recommended service and repair procedures to insure the fuel and emissions system is operating as designed and certified. Purposely or knowingly defeating or disabling any part of the fuel and emission system may be in violation of the anti-tampering provision of the EPA's Clean Air Act.
- Other special tools identified in this manual can be acquired through the equipment OEM or NGE.

IMPORTANT

It is important to remember that there may be a combination of Metric and Imperial fasteners used in the installation of the NGE fuel system. Check to insure proper fit when using a socket or wrench on any fastener to prevent damage to the component being removed or injury from "slipping off" the fastener.



WARNING

Always leak check any fuel system connection after servicing! Use an electronic leak detector and/or a liquid leak detection solution. Failure to leak check could result in serious bodily injury, death, or serious property damage.

Maintenance

MAINTENANCE

The maintenance of an engine and related components are critical to its operating performance and lifespan. Industrial engines operate in environments that often include hot and cold temperatures and extreme dust. The recommended maintenance schedule is listed in this section, however, environmental operating conditions and additional installed equipment may require more frequent inspection and servicing. The owner and/or service agent should review the operating conditions of the equipment to determine the inspection and maintenance intervals.



WARNING

When performing maintenance on the engine, turn the ignition OFF and disconnect the battery negative cable to avoid injury or damage to the engine.

The engine installed in this equipment uses a drive belt that drives the water pump, alternator and additional pumps or devices. It is important to note that the drive belt is an integral part of the cooling and charging system and should be inspected according to the maintenance schedule in this section. When inspecting the belts check for:

- Cracks
- Chunking of the belt
- Splits
- Material hanging loose from the belt
- Glazing, hardening

If any of these conditions exist the belt should be replaced with the recommended OEM replacement belt.

SERPENTINE BELT SYSTEM

Serpentine belts utilize a spring-loaded tensioner to keep the belt properly adjusted. Serpentine belts should be checked according to the maintenance schedule in this section.

IMPORTANT:

The use of “belt dressing” or “anti-slipping

agents” on belts is not recommended.

COOLING SYSTEM

It is important that the cooling system of the engine be maintained properly to ensure proper performance and longevity.



WARNING

Do not remove the cooling system pressure cap (radiator cap) when the engine is hot. Allow the engine to cool and then remove the cap slowly to allow pressure to vent. Hot coolant under pressure may discharge violently.

Note that there may be an LPG vaporizer connected to the cooling system and the fuel system may be adversely affected by low coolant levels and restricted or plugged radiator cores. Therefore, the cooling system must be maintained according to the recommend maintenance schedule in this section and also include:

- The regular removal of dust, dirt and debris from the radiator core and fan shroud.
- Inspection of coolant hoses and components for leaks, especially at the radiator hose connections. Tighten hose clamps if necessary.
- Check radiator hoses for swelling, separation, hardening, cracks or any type of deterioration. If any of these conditions exist the hose should be replaced with a recommended OEM replacement part.
- Inspect the radiator cap to ensure proper sealing.

COOLANT

The engine manufacturer recommends the cooling system be filled with a 50/50 mixture of antifreeze and water. The use of DexCool “Long Life” type coolant is required. The antifreeze must meet the specification GM6277M. This antifreeze is typically a bright orange in color and should meet the requirements issued by NGE. Coolant should have a minimum boiling point of 300F (149c) and a freezing point no higher than -34F (-37c). Do not add plain water. Replace coolant per the recommended schedule.

IMPORTANT:

The manufacturers of the engine and fuel system do not recommend the use of “stop leak” additives to repair leaks in the cooling system. If leaks are present the radiator should be removed and repaired or replaced.

ENGINE ELECTRICAL SYSTEM MAINTNANCE

The engine’s electrical system incorporates an electronic control module (ECM) to control various related components. The electrical system connections and ground circuits require good connections. Follow the recommended maintenance schedule in this section to maintain optimum performance. When inspecting the electrical system check the following:

- Check Positive and Negative cables for corrosion, rubbing, chafing, burning and to ensure tight connections at both ends.
- Check battery for cracks or damage to the case and replace if necessary.
- Inspect engine wire harness for rubbing, chafing, pinching, burning, and cracks or breaks in the wiring.
- Verify that engine harness connectors are correctly locked in by pushing in and then pulling the connector halves outward.
- Inspect ignition coil wire for hardening, cracking, arcing, chafing, burning, separation, split boot covers.
- Check spark plug wires for hardening, cracking, chafing, arcing or burning, separation, and split boot covers.
- Replace spark plugs at the required intervals per the recommended maintenance schedule.
- Verify that all electrical components are securely mounted to the engine or chassis.

- Verify that any additional electrical services installed by the owner are properly installed in the system.
- Verify that the MIL, charging, and oil pressure lights illuminate momentarily during engine start.

ENGINE CRANKCASE OIL

OIL RECOMMENDATION

To achieve proper engine performance and durability, it is important that you only use engine lubricating oils displaying the American Petroleum Institute (API) “Starburst” Certification Mark ‘FOR GASOLINE ENGINES’ on the container.



IMPORTANT:

Oils recommended by the engine manufacturer already contain a balanced additive treatment. Oils containing “solid” additives, non-detergent oils, or low quality oils are not recommended by the engine manufacturer. Supplemental additives added to the engine oil are not necessary and may be harmful. The engine and fuel system supplier do not review, approve or recommend such products.

Multi-viscosity oil is recommended. SAE 15W-40 is recommended for your NGE industrial product. Synthetic oils are not recommended for industrial or stationary engines. The ash content should be less than 0.5% ash content; the use of medium ash content will void the catalyst warranty.

CHECKING/FILLING ENGINE OIL LEVEL

IMPORTANT:

Care must be taken when checking engine oil level. Oil level must be maintained between the “ADD” mark and the “FULL” mark on the dipstick. To ensure that you are not getting a false reading, make sure the following steps are taken before checking the oil level.

1. Stop engine.
2. Allow approximately several minutes for the oil to drain back into the oil pan.
3. Remove the dipstick. Wipe with a clean cloth or paper towel and reinstall. Push the dipstick all the way into the dipstick tube.
4. Remove the dipstick and note the amount of oil on the dipstick. The oil level must be between the "FULL" and "ADD" marks.

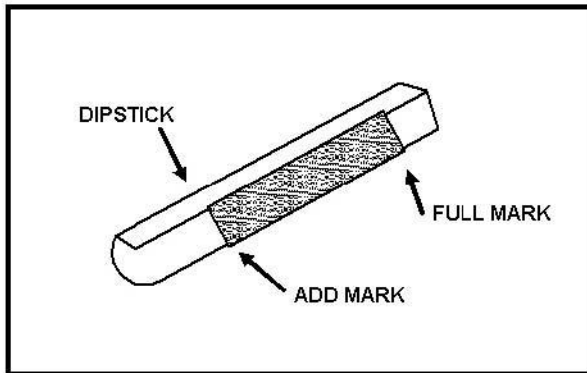

Figure 2 Engine Oil Dip tick (Typical)

5. If the oil level is below the "ADD" mark reinstall the dipstick into the dipstick tube and proceed to Step 6.
6. Remove the oil filler cap from the valve cover.
7. Add the required amount of oil to bring the level up to, but not over, the "FULL" mark on the dipstick. Reinstall the oil filler cap to the valve rocker arm cover and wipe any excess oil clean.

CHANGING THE ENGINE OIL

IMPORTANT:

When changing the oil, always change the oil filter.

1. Start the engine and run until it reaches normal operating temperature.



CAUTION

An overfilled crankcase (oil level being too high) can cause an oil leak, a fluctuation or drop in oil pressure. When overfilled, the engine crankshafts splash and agitate the oil, causing it to aerate or foam.

Change oil when engine is warm and the old oil flows more freely.

2. Stop engine

IMPORTANT:

Engine oil will be hot. Use protective gloves to prevent burns. Engine oil contains chemicals which may be harmful to your health. Avoid skin contact.

3. Remove drain plug and allow the oil to drain.
4. Remove and discard oil filter and its sealing ring.
5. Coat sealing ring on the new filter with clean engine oil, wipe the sealing surface on the filter mounting surface to remove any dust, dirt or debris. Tighten filter securely (follow filter manufacturers instructions). Do not over tighten.
6. Check sealing ring on drain plug for any damage, replace if necessary, wipe plug with clean rag, wipe pan sealing surface with clean rag and re-install plug into the pan. Tighten to specification.
7. Fill crankcase with oil.
8. Start engine and check for oil leaks.
9. Dispose of oil and filter in a safe manner.

IMPORTANT:

FUEL SYSTEM INSPECTION AND MAINTENANCE

NG FUEL SYSTEM

The fuel system installed on this industrial engine has been designed to meet the stationary engine emission standard applicable for the 2009 and later model years. To ensure compliance to these standards, follow the recommended maintenance schedule contained in this section.

INSPECTION AND MAINTENANCE OF THE FUEL STORAGE CYLINDER

The fuel storage cylinder should be inspected daily or at the beginning of each operational shift for any leaks, external damage, adequate fuel supply and to ensure the manual service valve is open. Fuel storage cylinders should always be securely mounted, inspect the securing straps or retaining devices for damage ensure that all locking devices are closed and locked. Check to ensure that the fuel storage cylinder is positioned with the locating pin in the tank collar on all horizontally mounted cylinders this will ensure the proper function of the cylinder relief valve.

When refueling or exchanging the fuel cylinder, check the quick fill valve for thread damage. Also verify O-ring is in place and inspect for cracks, chunking or separation. If damage to the o-ring is found, replace prior to filling. Check the service line quick coupler for any thread damage.

IMPORTANT:

When refueling the fuel cylinder, wipe both the female and male connection with a clean rag prior to filling to prevent dust, dirt and debris from being introduced to the fuel cylinder.

INSPECTION AND REPLACEMENT OF THE FUEL FILTER

The fuel system on this emission certified engine may utilize an in-line replaceable fuel filter element. This element should be replaced, at the intervals specified in the recommended maintenance schedule. When inspecting the fuel filter check the following:

- Check for leaks at the inlet and outlet fittings, using a soapy solution or an electronic leak detector and repair if necessary.

- Check to make sure filter is securely mounted.
- Check filter housing for external damage or distortion. If damaged replace fuel filter.

REPLACING THE FUEL FILTER:

1. Move the equipment to a well ventilated area and verify that sparks, ignition and any heat sources are not present.
2. Start the engine.
3. If the engine operates on a positive pressure fuel system, run the engine with the fuel supply closed to remove fuel from the system.

IMPORTANT:

A small amount of fuel may still be present in the fuel line. Use gloves and proper eye protection to prevent burns. If liquid fuel continues to flow from the connections when removed, make sure the manual valve is fully closed.

4. Slowly loosen the inlet fitting and disconnect.
5. Slowly loosen the outlet fitting and disconnect.
6. Remove the filter housing from the equipment.
7. Check for contamination.
8. Tap the opening of the filter on a clean cloth.
9. Check for debris.
10. Check canister for proper mounting direction.
11. Reinstall the filter housing to the equipment.
12. Tighten the inlet and outlet fittings to specification.
13. Check for leaks at the inlet and outlet fittings, and the filter housing end connection using a soapy solution or an electronic leak detector, if leaks are detected make repairs

DIRECT ELECTRONIC PRESSURE REGULATOR (DEPR) MAINTENANCE AND INSPECTION

IMPORTANT:

The Direct Electronic Pressure Regulator (DEPR) components have been specifically designed and calibrated to meet the fuel system requirements of the emission certified engine.

If the DEPR fails to operate or develops a leak, it should be repaired or replaced with the OEM recommended replacement parts. When inspecting the system check for the following items:

- Check for any fuel leaks at the inlet and outlet fittings.
- Check for any fuel leaks in the DEPR body.
- Check the inlet and outlet fittings of the coolant supply lines for water leaks if applicable.
- Check to ensure the DEPR is securely mounted and the mounting bolts are tight.
- Check DEPR for external damage.
- Check DEPR electrical connection to ensure the connector is seated and locked.

CHECKING/DRAINING OIL BUILD-UP IN THE VAPORIZER REGULATOR

During the course of normal operation for LPG engines oil or “heavy ends” may build inside the secondary chamber of the Vaporizer Regulator. These oil and heavy ends may be a result of poor fuel quality, contamination of the fuel, or regional variation of the fuel make up. A significant build up of oil can affect the performance of the secondary diaphragm response. The Recommended Maintenance Schedule found in this section recommends that the oil be drained periodically. This is the minimum requirement to maintain the emission warranty. More frequent draining of the Vaporizer Regulator is recommended where substandard fuel may be a problem. NGE recommends the Vaporizer Regulator be drained at every engine oil change if contaminated or substandard fuel is suspected or known to be have been used or in use with the emission complaint fuel system. This is known as special maintenance, and failure to follow this recommendation may be used to deny a warranty claim.

IMPORTANT:

Draining the regulator when the engine is warm

will help the oils to flow freely from the regulator.

To drain the regulator, follow the steps below:

1. Move the equipment to a well ventilated area and ensure no external ignition sources are present.
2. Start the engine.
3. With the engine running close the manual valve.
4. When the engine runs out of fuel turn OFF the key when the engine stops and disconnect the negative battery cable.

IMPORTANT:

A small amount of fuel may still be present in the fuel line, use gloves to prevent burns, wear proper eye protection. If liquid fuels continues to flow from the connections when loosened check to make sure the manual valve is fully closed.

5. Loosen the hose clamp at the inlet and outlet hoses and remove the hoses.
6. Remove the regulator mounting bolts.
7. Place a small receptacle in the engine compartment.
8. Rotate the regulator to 90° so that the outlet fitting is pointing down into the receptacle and drain the regulator.
9. Inspect the secondary chamber for any large dried particles and remove.
10. Remove the receptacle and reinstall the regulator retaining bolts and tighten to specifications.
11. Reinstall the fuel hoses.
12. Reconnect any other hoses removed during this procedure.
13. Slowly open the manual service valve.

IMPORTANT:

The fuel cylinder manual valve contains an “Excess Flow Check Valve” open the manual valve slowly to prevent activating the “Excess Flow Check Valve.”

14. Check for leaks at the inlet and outlet fittings using a soapy solution or an electronic leak detector. If leaks are detected make repairs. Check coolant line connections to ensure no leaks are present.
15. Start engine recheck for leaks at the regulator.
16. Dispose of any drained material in safe and proper manner.

AIR FUEL MIXER/THROTTLE CONTROL DEVICE MAINTENANCE AND INSPECTION

IMPORTANT:

The Air Fuel Mixer components have been specifically designed and calibrated to meet the fuel system requirements of the emission certified engine. The mixer should not be disassembled or rebuilt. If the mixer fails to operate or develops a leak the mixer should be replaced with the OEM recommended replacement parts.

When inspecting the mixer check for the following items:

- Leaks at the inlet fitting.
- Fuel inlet hose for cracking, splitting or chaffing, replace if any of these conditions exist.
- Ensure the mixer is securely mounted and is not leaking vacuum at the mounting gasket or surface.
- Inspect air inlet hose connection and clamp. Also inspect inlet hose for cracking, splitting or chafing. Replace if any of these conditions exist.
- Inspect Air cleaner element according to the Recommended Maintenance Schedule found in this section.
- Check Fuel lines for cracking, splitting or chafing. Replace if any of these conditions exist.
- Check for leaks at the throttle body and intake manifold.

EXHAUST SYSTEM AND CATALYTIC CONVERTER INSPECTION AND MAINTENANCE

IMPORTANT:

The exhaust system on this emission certified engine contains a Heated Exhaust Gas Oxygen Sensor (HEGO) which provides feed back to the ECM on the amount of oxygen present in the exhaust stream after combustion.

The oxygen in the exhaust stream is measured in voltage and sent to the ECM. The ECM then makes corrections to the fuel air ratio to ensure the proper fuel charge and optimum catalytic performance. Therefore, it is important that the exhaust connections remain secured and air tight.

IMPORTANT:

The HEGO sensor is sensitive to silicone based products. Do not use silicone sprays or hoses which are assembled using silicone lubricants. Silicone contamination can cause severe damage to the HEGO.

When inspecting the Exhaust system check the following:

- Exhaust manifold at the cylinder head for leaks and that all retaining bolts and shields (if used) are in place.
- Manifold to exhaust pipe fasteners to ensure they are tight and that there are no exhaust leaks repair if necessary.
- HEGO electrical connector to ensure connector is seated and locked, check wires to ensure there is no cracking, splits chafing or "burn through." Repair if necessary.
- Exhaust pipe extension connector for leaks tighten if necessary
- If the engine is equipped with a catalytic converter inspect the converter to ensure it is securely mounted.
- Check for any leaks at the inlet and outlet of the converter.

ENGINE MAINTENANCE REQUIREMENTS

Perform the following maintenance on the engine at the hours indicated and at equivalent hour intervals thereafter.

| | Interval Hours | | | | | |
|---|----------------|-----|-----|------|------|-------|
| | Daily | 200 | 500 | 1000 | 8000 | 25000 |
| General Maintenance Section | | | | | | |
| Visual check for fluid leaks | X | | | | | |
| Check engine oil level | X | | | | | |
| Check coolant level | X | | | | | |
| Change engine oil and filter ^{1, **} | | X | | | | |
| Change Crankcase Ventilation Filters | | X | | | | |
| Inspect accessory drive belts for cracks, breaks, splits or glazing | | | | X | | |
| Inspect and Adjust Belt Tension ¹ | | | X | | | |
| Inspect electrical system wiring for cuts, abrasions or corrosion | | | | X | | |
| Inspect all vacuum lines and fittings for cracks, breaks or hardening | | | | X | | |
| Check and adjust intake and exhaust valve clearance ¹ | | | X | | | |
| Grease fan tensioner pulley grease fitting | | | | X | | |
| Engine Coolant Section | | | | | | |
| Clean debris from radiator core | | X | | | | |
| Change coolant | | | | X | | |
| Inspect coolant hoses for cracks, swelling or deterioration | | | | X | | |
| Engine Ignition System | | | | | | |
| Replace spark plugs | | | | X | | |
| Check ignition coil | | | | X | | |
| Fuel System Maintenance | | | | | | |
| Inspect air cleaner *** | | X | | | | |
| Replace air filter element | | | | X | | |
| Inspect Shut-off Valve for leaks and closing | | | | X | | |
| Leak check fuel lines | | | | X | | |
| Check air induction for leaks | | | | X | | |
| Check manifold for vacuum leaks | | | | X | | |
| Drain LPL vaporizer oil build up | | | | X | | |
| Engine Exhaust System | | | | | | |
| Inspect exhaust manifold for leaks | | | | X | | |
| Inspect exhaust piping for leaks | | | | X | | |
| Check HEGO sensors, connector and wires for burns, cuts or damage | | | | X | | |
| Inspect catalyst for mechanical damage | | | | X | | |
| Engine Overhaul | | | | | | |
| Top End **** | | | | | X | |
| Bottom End **** | | | | | | X |

¹ FIRST 50 HOURS OF OPERATION

** Or every 120 days

*** Every 100 hours in dusty environment

**** Inspect and measure components, replace as necessary

This maintenance schedule represents the manufacturer's recommended maintenance intervals to maintain proper engine function.

Fuel System

STATIONARY ENGINE FUEL SYSTEM SCHEMATIC

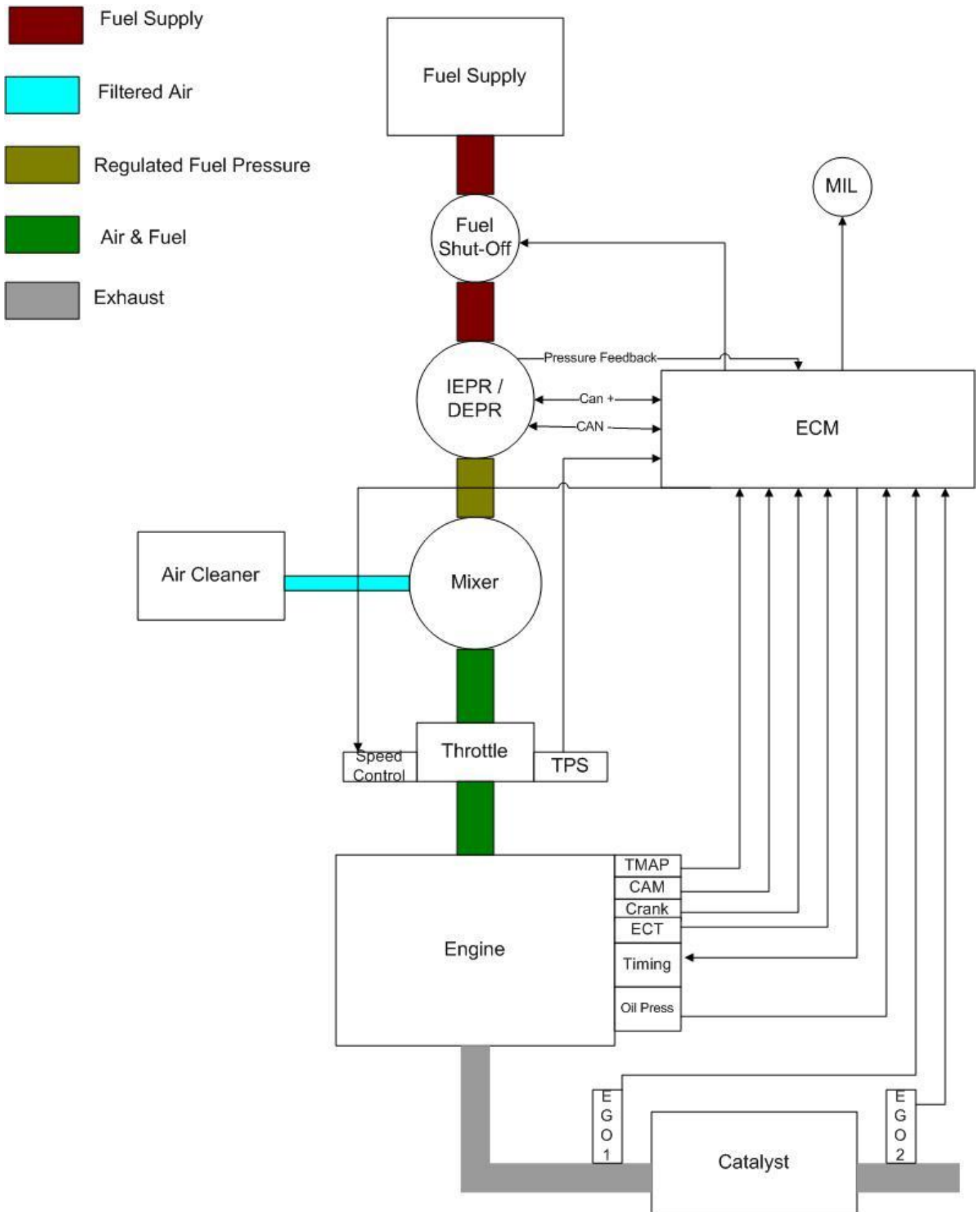

DESCRIPTION AND OPERATION OF THE FUEL SYSTEMS

NG & LP VAPOR FUEL SYSTEM

The primary components of the fuel system are the fuel supply, direct electronic pressure regulator (DEPR), fuel mixer, electronic throttle control (ETC) device, electric Shut-Off Valve, engine control module (ECM), and a catalytic converter. The system operates at pressures which range from 7 to 11 inches of water column for NG and LP Vapor.

SERVICE LINES

Fuel flows from the fuel supply to the electric Shut-Off Valve and then to the DEPR via the service lines. The service lines are not supplied by the engine manufacturer. Please contact the equipment manufacturer regarding fuel service lines

FUEL FILTER

LP, fuel like all other motor fuels is subject to contamination from outside sources. Refueling of the equipment tank and removal of the tank from the equipment can inadvertently introduce dirt and other foreign matter into the fuel system. It is therefore necessary to filter the fuel prior to entering the fuel system components down stream of the tank. An inline fuel filter has been installed in the fuel system to remove the dirt and foreign matter from the fuel, which is replaceable as a unit only. Maintenance of the filter is critical to proper operation of the fuel system and should be replaced according to the maintenance schedule or more frequently under severe operating conditions.

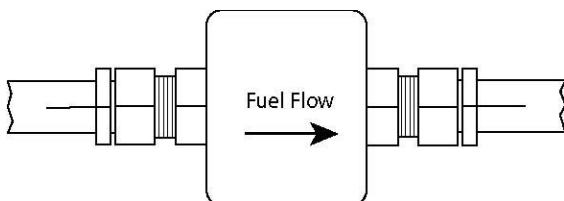

Inline Fuel Filter

ELECTRIC FUEL SHUT-OFF VALVE

The Electric Fuel Shut-Off Valve is an integrated assembly consisting of a 24 volt solenoid and a normally closed valve. When energized, the solenoid opens the valve and allows the fuel to flow through the device. The valve opens during cranking and engine run cycles.



Voltage to the Electric Shut-Off Valve may be controlled by the engine control module (ECM) or by equipment manufacturer's system controller.

DIRECT ELECTRONIC PRESSURE REGULATOR (DEPR)

The DEPR is an electronic pressure regulating device. The DEPR functions as a regulator with the ability to supply additional fuel by command from the ECM. When the engine is cranking or running, a partial vacuum is created in the fuel line which connects the regulator to the mixer. This partial vacuum opens the regulator permitting fuel to flow to the mixer.

Fuel enters the DEPR and passes through the actuator valve to the mixer. Fuel pressure between the mixer and the DEPR outlet is monitored and the actuator valve is controlled based on pressure feedback and command. An increase in the amount of time the valve is open increases fuel supply pressure to the mixer. A

decrease in the amount of time the valve is open decreasing fuel supply pressure to the mixer.

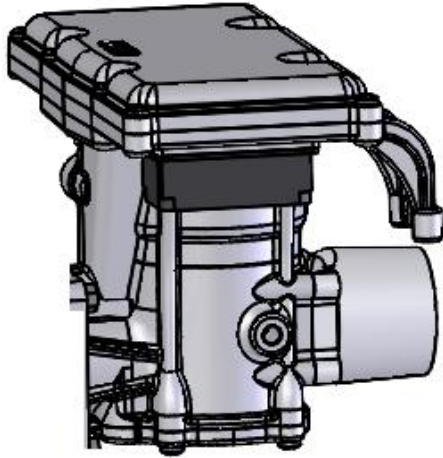

Direct Electronic Pressure Regulator



CAUTION

The DEPR is an emission control device and should only be serviced by qualified technicians.

AIR FUEL MIXER

The air valve mixer is a self-contained air-fuel metering device. The mixer is an air valve design, utilizing a relatively constant pressure drop to draw fuel into the mixer from cranking speeds to full load. The mixer is mounted in the air stream ahead of the throttle control device.

When the engine begins to crank it draws in air with the air valve covering the inlet, and negative pressure begins to build. This negative pressure signal is communicated to the top of the air valve chamber through vacuum ports in the air valve assembly. A pressure/force imbalance begins to build across the air valve diaphragm between the air valve vacuum chamber and the atmospheric pressure below the diaphragm. The vacuum being created is referred to as Air Valve Vacuum (AVV). As the air valve vacuum reaches the imbalance point, the air valve begins to lift against the air valve spring. The amount of AVV generated is a direct result of the

throttle position. At low engine speed the air valve vacuum and the air valve position is low thus creating a small venturi for the fuel to flow. As the engine speed increases the AVV increases and the air valve is lifted higher thus creating a much larger venturi. This air valve vacuum is communicated from the mixer venturi to the DEPR via the fuel supply hose.

The mixer is equipped with a low speed mixture adjustment retained in a tamper proof housing. The mixer has been preset at the factory and should not require adjustment. In the event that the idle adjustment should need to be adjusted refer to the Fuel System Repair section of this manual.



CAUTION

The air/fuel mixer is an emission control device. Components inside the mixer are specifically calibrated to meet the engine's emissions requirements and should never be disassembled or rebuilt. If the mixer fails to function correctly, replace with an OEM replacement part.

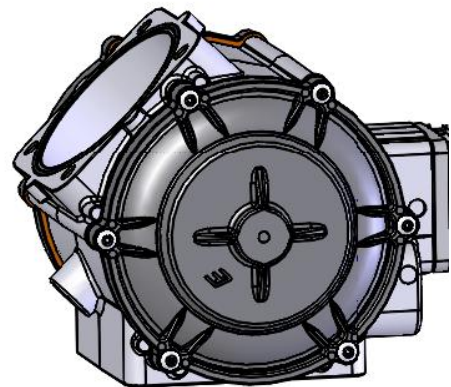

Air Valve Mixer

ELECTRONIC THROTTLE CONTROL DEVICE (ETC)—

Engine speed is controlled by the ECM and the Electronic Throttle Control device which is an au-

tomotive style throttle. The ECM controls engine speed one of several ways depending on the equipment manufacturer's requirement. Engine speed can be controlled by discrete speed governing, whereby the OEM sends an open, high or low voltage signal to an ECM pin. The ECM then targets the preprogrammed speed for that pin.

The ECM then sends an electrical signal to the motor on the electronic throttle control to increase or decrease the angle of the throttle blade thus increasing or decreasing the air/fuel charge to the engine. The electronic throttle control device incorporates two internal Throttle Position Sensors (TPS) which provide output signals to the ECM as to the location of the throttle shaft and blade. The TPS information is used by the ECM to correct for speed and load control as well as emission.

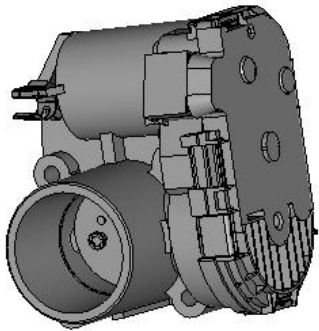

Electronic Throttle Control Device

THREE-WAY CATALYTIC CONVERTER

The Catalytic Converter is a component of the emissions system which is designed to meet the emission standards in effect for model years 2009 and beyond stationary engines.

The exhaust gases pass through the honeycomb catalyst which is coated with a mixture of precious group metals to oxidize and reduce CO, HC and NOX emission gases.

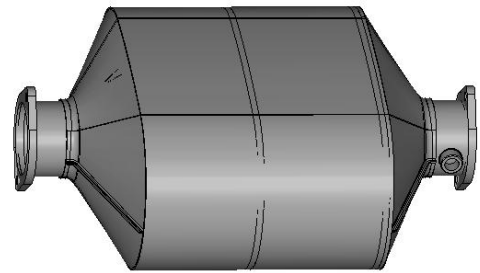

Three Way Catalytic Converter

ENGINE CONTROL MODULE

To obtain maximum effect from the catalyst and accurate control of the air fuel ratio, the emission certified engine is equipped with an onboard computer or Engine Control Module (ECM). The ECM is a 32 bit controller which receives input data from sensors mounted to the engine and fuel system and then outputs various signals to control engine operation.

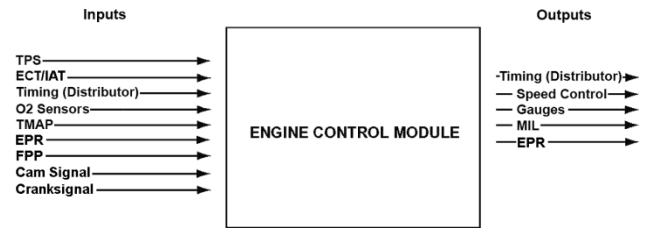

Engine Control Module (ECM)

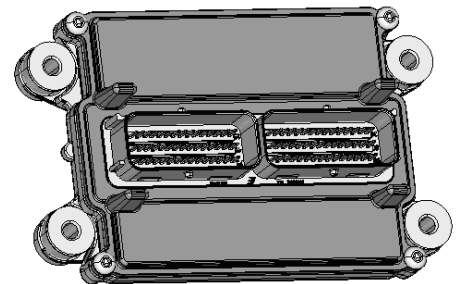

Engine Control Module (ECM)

One specific function of the controller is to maintain a closed loop fuel control which is accomplished by use of the Heated Exhaust Gas Oxygen sensor (HEGO) mounted in the exhaust system. The HEGO sensor sends a voltage signal to the controller which then outputs signals to the EPR to change the amount of fuel being delivered from the regulator or mixer to the engine.

The controller also performs diagnostic functions on the fuel system and notifies the operator of engine malfunctions by turning on a Malfunction Indicator Light (MIL) mounted in the dash. Malfunctions in the system are identified by a Diagnostic Trouble Code (DTC) number. In addition to notifying the operator of the malfunction in the system, the controller also stores the information about the malfunction in its memory. A technician can then utilize a computerized diagnostic scan tool to retrieve the stored diagnostic code and by using the diagnostic charts in this manual to determine the cause of the malfunction. In the event a technician does not have the computerized diagnostic tool, the MIL light can be used to identify the diagnostic code to activate the “blink” feature and count the number of blinks to determine the diagnostic code number to locate the fault in the system.

HEATED EXHAUST GAS OXYGEN SENSORS

The Heated Exhaust Gas Oxygen (HEGO) Sensors are mounted in the exhaust system, one upstream and one downstream of the catalytic converter. Models that do not use a catalyst assembly will only use one HEGO sensor.

The HEGO sensors are used to measure the amount of oxygen present in the exhaust stream to determine whether the air-fuel ratio is too rich or too lean. It then communicates this measurement to the ECM. If the HEGO sensor signal indicates that the exhaust stream is too rich, the ECM will decrease or lean the fuel mixture during engine operation. If the mixture is too lean, the ECM will richen the mixture. If the ECM determines that a rich or lean condition is present for an extended period of time which cannot be corrected, the ECM will set a diagnostic code and turn on the MIL light in the dash.

By monitoring output from the sensor upstream

and the sensor downstream of the catalytic converter, the ECM can determine the performance of the catalyst.



The Heat Exhaust Gas Oxygen (HEGO) Sensor

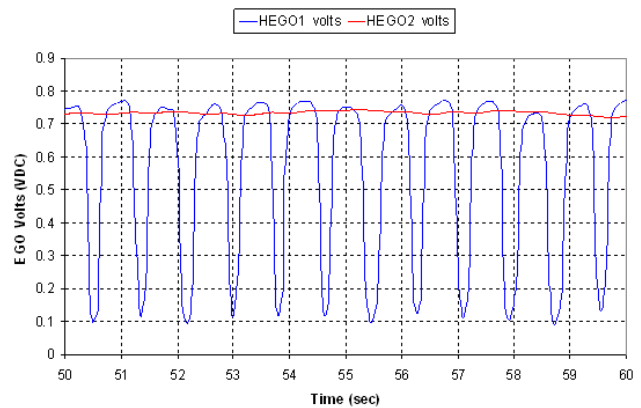

HEGO1 (upstream or before the catalytic converter) and HEGO2 (downstream) voltage output.



CAUTION

The Heated Exhaust Gas Oxygen Sensor (HEGO) is an emissions control component. In the event of a failure, the HEGO should only be replaced with the recommended OEM replacement part. The HEGO is sensitive to silicone based products and can become contaminated. Avoid using silicone sealers or air or fuel hoses treated with a silicone based lubricant.

TMAP SENSOR

The Temperature Manifold Absolute Pressure or TMAP sensor is a variable resistor used to monitor the difference in pressure between the intake manifold and outside or atmospheric pressure and the temperature. The ECM monitors the resistance of the sensor to determine engine load (the vacuum drops when the engine is under load or at wide open throttle). When the engine is under load, the computer may alter the fuel mixture to improve performance and emissions. The temperature is also monitored by the ECM, primarily to richen the fuel/air mixture during a cold start.

COOLANT TEMPERATURE SENSOR

The Engine Coolant Temperature sensor or ECT is a variable resistance thermistor that changes resistance as the engine's coolant temperature changes. The sensor's output is monitored by the ECM to determine a cold start condition and to regulate various fuel and emission control functions via a closed loop emission system.

OIL PRESSURE SENDER

The Engine Oil Pressure sensor is designed to ensure adequate lubrication throughout the engine. It provides a pressure value for the oil pressure gauge and is monitored by the ECM. If the pressure drops, an MIL will occur.

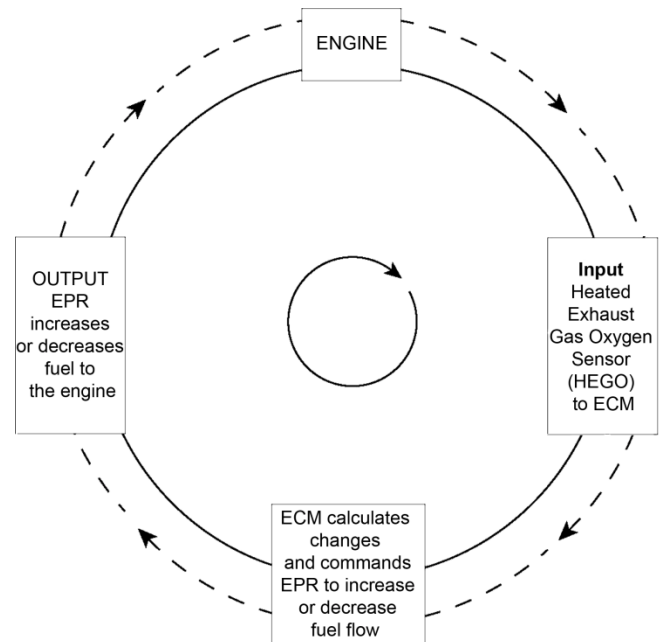

Closed-Loop Fuel Control

Fuel System Diagnosis

FUEL SYSTEM DIAGNOSIS

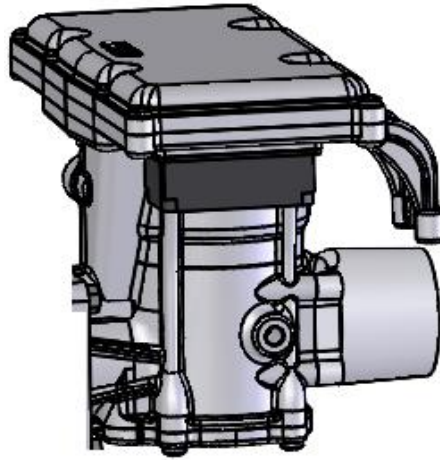

Direct Electronic Pressure Regulator Assembly

FUEL SYSTEM DESCRIPTION

The Engine Control Module (ECM) receives information from various engine sensors in order to control the operation of the Direct Electronic Pressure Regulator (DEPR) and Shut-Off Valve. The Shut-Off Valve solenoid prevents fuel flow unless the engine is cranking or running.

When the engine begins cranking the shut-off valve will open and allow fuel to pass through the valve.

The fuel then travels to the mixer. Engine cranking generates vacuum which provided lift for the mixer air valve and is commonly referred to as air valve vacuum. Once in the mixer, the fuel is combined with air and is drawn into the engine for combustion.

DIAGNOSTIC AIDS

This procedure is intended to diagnose equipment operating on NG or LPG. If the equipment will not continue to run, refer to Hard Start for preliminary checks. Before starting this procedure, complete the following tasks to verify that fuel is being delivered to the DEPR:

- Inspect the fuel supply lines to verify they are

properly connected and do not have any kinks or damage

- Verify the fuel shut off valve is operating properly. Refer to the OEM for information on the fuel shut off valve.
- Verify the ECM is selecting the proper fuel type by using the DST. You can view this under the faults page on the “fuel type” line.

TOOLS REQUIRED:

DST

- Diagnostic Scan Tool (DST)

PRESSURE GAUGES

- 0-20” Water Column Gauge

TEST DESCRIPTION

The basis of the fuel system test is to determine if the fuel is operating within proper fuel control parameters. This fuel control system operates on the basis of short term and long term fuel correction to compensate for the normal operation and aging of the engine. Abnormal operation of the engine, due to a component issue or lack of maintenance will cause fuel system control parameters to operate outside of the normal range.

The fuel system correction factors are viewable using the laptop based Diagnostic Service Tool (DST).

The short term correction factor is a percentage based fuel correction that will immediately be applied once the engine reaches the closed loop fuel control mode. The short term correction factor is known as "Closed Loop 1" on the DST.

The long term correction factor writes the short term correction into long term memory so it is available immediately on the next start/run cycle. The long term correction factor is known as "Adaptive 1" on the DST.

Closed Loop 1 and Adaptive 1 can be viewed on the Closed Loop Control panel on the Faults Page of the DST.

The screenshot shows the E-Controls, Inc. Diagnostic Service Tool (DST) interface. The 'Closed-Loop Control' panel is highlighted with a red circle, showing the following data:

| Parameter | Value |
|--------------------------------|-------------|
| EG01 | 0.229 volts |
| Closed-loop 1 | 0.0 % |
| Adaptive 1 | 0.0 % |
| Closed-loop 2 | 0.0 % |
| Adaptive 2 | 0.0 % |
| EG03 | 0.346 volts |
| Post-cat CL offset | 0.000 phi |
| Alternate-Fuel trim duty cycle | 0.0 % |

Other visible panels include 'System States', 'Monitored Drivers', 'Input Voltages', and 'Diagnostic Modes'.

Closed Loop 1 & Adaptive 1

Any parameter found to be out of conformance will require additional diagnosis.

HOW THE CORRECTION FACTORS WORK

The correction factors are displayed in the DST as a positive or negative percent. The numbers will range between -35% and +35%. A negative fuel correction number indicates the removal of fuel.

An outside condition causing the system to be rich, such as a restricted air cleaner, can cause a negative short term and long term fuel correction. An outside condition causing the system to be lean, such as a vacuum leak, can cause a positive fuel correction.

DETERMINING TOTAL FUEL CORRECTION

The total fuel correction is the sum of the short term correction (Closed Loop 1) and the long term correction (Adaptive 1).

For instance, a Closed Loop 1 reading of -1.5% and an Adaptive 1 reading of -3.5% would mean a total fuel correction of -5% was taking place at that time. The system is removing 5% fuel at that time.

A Closed Loop 1 reading of 1.5% and an Adaptive 1 reading of 3.5% (note both are positive numbers) would mean that a total fuel correction of 5% was taking place at that time. The system is adding 5% fuel.

NORMAL & ABNORMAL FUEL CORRECTION

Generally, the system is operating within specification when total fuel correction falls between -15% and +15%. Operation outside of this range will require further diagnosis to determine the system level issue affecting fuel control. The system will set Diagnostic Trouble Codes (DTC's) for correction factors in the +/- 30%-35% range.

If total fuel correction is found to be operating outside of the normal range additional diagnostic procedure will be required to determine the cause. Follow the appropriate Symptom Routine or DTC Chart for additional help.

Total Fuel Correction Chart

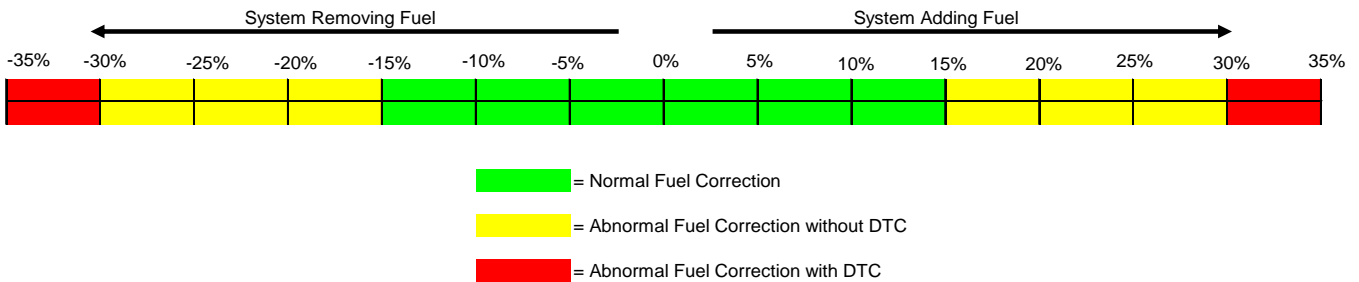

Fuel System Diagnosis

| Step | Action | Value(s) | Yes | No |
|------|---|---------------------|--------------------------------|-------------------------|
| 1 | Were you referred to this procedure by a DTC diagnostic chart? | | Go to Step 3 | Go to Step 2 |
| 2 | 1. Perform the On Board Diagnostic (OBD) System Check. Are any DTC's present in the ECM? | | Go to the applicable DTC Table | Go to Step 3 |
| 3 | 1. Verify that the fuel supply lines are connected properly without any kinks or damage Are fuel supply lines ok? | | Go to Step 4 | Repair and Go to Step 4 |
| 4 | 1. Connect the DST and start the engine and allow it to reach operating temperature. Does the engine start and run? | | Go to Step 5 | Go to Step 11 |
| 5 | 1. Bring the engine to operating speed and slowly increase the load in increments to full load. Does the engine pull full load? | | Go to Step 6 | Go to Step 13 |
| 6 | 1. Return the engine to its lowest operating speed and load. 2. View the DST and make sure the fuel control mode is "Closed Loop + Adapt". Note: The engine must be at 165°F or higher to reach this fuel control mode. Is the fuel control mode correct? | Closed Loop + Adapt | Go to Step 7 | Go to Step 22 |
| 7 | 3. Continue to run the engine at its lowest speed and load and check EGO1 voltage. Is EGO fluctuating rapidly? | | Go to Step 8 | Go to Step 23 |
| 8 | 1. Continue to operate the engine at its lowest speed and no load. 2. Using the DST observe Closed Loop 1 and Adaptive 1 and calculate total fuel correction. Is total fuel correction within the specified range? | -15% to +15% | Go to Step 9 | Go to Step 24 |
| 9 | 1. Raise the engine rpm to operating speed and load the engine to a mid-load point. 2. Using the DST observe Closed Loop 1 and Adaptive 1 and calculate total fuel correction. Is total fuel correction within the specified range? | -15% to +15% | Go to Step 10 | Go to Step 24 |

| Step | Action | Value(s) | Yes | No |
|------|---|--------------------|----------------------------|---------------------------------------|
| 10 | <ol style="list-style-type: none"> 1. Run the engine at operating speed and raise the load to full-load. 2. Using the DST observe Closed Loop 1 and Adaptive 1 and calculate total fuel correction. 3. Is total fuel correction within the specified range? | -15% to +15% | Go to 25 | Go to Step 24 |
| 11 | <ol style="list-style-type: none"> 1. Connect the DST 2. Turn the key on and set the DST view to the "Faults" page 3. Crank the engine and view the Gaseous Pressure Target and Gaseous Pressure Actual values. <p>Is there fuel pressure registered in Gaseous Pressure Actual and does it match Gaseous Pressure Target within .5" w.c.?</p> | | Go to Step 12 | Go to Step 14 |
| 12 | <ol style="list-style-type: none"> 4. Remove Air induction hose to the mixer. 5. Observe the air valve for movement while the engine is cranking. <p>Note: Movement of the air valve will be minimal at cranking speeds. Does the air valve move when the engine is cranked?</p> | | Go to Ignition System Test | Go to Step 13 |
| 13 | <ol style="list-style-type: none"> 1. Inspect the air intake stream to the mixer assembly and the throttle body for vacuum leaks. <p>Were vacuum leaks found and repaired?</p> | | Return to Step 4 | Go to Step 21 |
| 14 | <ol style="list-style-type: none"> 1. Inspect the fuel supply hose between the source and the DEPR and the mixer assembly for damage or leakage. <p>Was a problem found and repaired?</p> | | Return to Step 4 | Go to Step 15 |
| 15 | <ol style="list-style-type: none"> 1. Connect a water column gauge or manometer to the fuel supply hose between the fuel source and the fuel shut off valve. <p>Is fuel pressure in the specified range?</p> | 7"-11" w.c. | Go to Step 16 | Repair fuel source and Move to Step 4 |
| 16 | <ol style="list-style-type: none"> 1. Connect a water column gauge or manometer to the fuel supply hose between the fuel shut off valve and the DEPR. <p>Is fuel pressure within specified range?</p> | 7"-11" w.c. | Go to Step 19 | Go to Step 17 |
| 17 | <ol style="list-style-type: none"> 1. Turn OFF the ignition. 2. Connect volt meter across the harness side of the fuel shut off solenoid connector 3. Crank the engine. <p>Is voltage present?</p> | 19+V. volts | Go to Step 20 | Go to Step 18 |

| Step | Action | Value(s) | Yes | No |
|------|--|----------|-------------------------------|--|
| 18 | 1. Repair the open or broken electrical connection in the Shut-Off Valve circuit. Is the action complete? | | Go to Step 25 | |
| 19 | 1. Replace the DEPR. Refer to Integrated Electronic Pressure Regulator Repair. Is the action complete? | | Go to Step 4 and Restart Test | Recheck DTC's and try Additional Steps |
| 20 | 1. Replace the Shut-Off Valve. Refer to the <i>Shut-Off Valve Replacement</i> . Is the action complete? | | Go to Step 4 and Restart Test | |
| 21 | 1. Replace the mixer assembly. Refer to <i>Fuel Mixer Replacement</i> . Is the action complete? | | Go to Step 4 and Restart Test | |
| 22 | Check that the engine is reaching normal operating temperature. If engine is not reaching temperature diagnose problem with cooling system. If engine is reaching 165°F and does not go into Closed Loop mode check operation of O2 sensor and recheck DTC's. Was a problem found and repaired? | | Go to Step 6 | Recheck DTC's and Repair |
| 23 | Disconnect EGO1 connector and check heater circuit for 12V and ground. If present replace O2 sensor. If 12V and ground not present repair circuit. Check for DTC and follow DTC chart. Was a problem found and repaired? | | Go to Step 7 | Recheck DTC and follow DTC diagnosis |
| 24 | You were referred to this step because the total fuel correction was found to be out of tolerance. Check the system for pinched cut or disconnected vacuum hoses or electrical connections. Check for a restricted or missing air filter. Check for loose mounting hardware for the mixer and DEPR. Check to see that actual engine coolant temperature matches the Engine Coolant Temperature (ECT) reading with the DST. Was a problem found and corrected? | | Go to Step 4 and restart Test | Recheck DTC's and try Additional Steps |
| 25 | The Fuel Control System is operating normally. Remove all test equipment. | | System OK | |

ADDITIONAL STEPS

| STEP | ACTION | VALUE(S) | YES | NO |
|------|--|------------|----------------------------|-----------------------------|
| 1 | 1. Perform the On-Board Diagnostic (OBD) System check. Are any DTCs present in the ECM? | | Go to Applicable DTC Table | Go to Step 2 |
| 2 | Has the Fuel system diagnosis been performed? | | Go to Step 3 | Go to Fuel system Diagnosis |
| 3 | 1. Replace the Engine Control Unit (ECM). Refer to Engine Control Unit (ECM) replacement. Is this action complete? | | Go to Step 5 | Go to Step 4 |
| 4 | 1. Repair the open or damaged circuit. Is this action complete? | | Go to Step 5 | Go to Step 8 |
| 5 | 1. Return the fuel system to normal operating condition. 2. Observe the Adaptive 1 fuel correction. 3. Raise the engine speed to approximately 2500 rpm. Is the Adaptive 1 fuel correction within the specified range at idle and 2500 rpms? | -15 to +15 | Go to Step 9 | Go to Step 6 |
| 6 | 1. Check all vacuum hoses and mixer connections for leakage. Was a problem found? | | Go to Step 5 | Go to Step 7 |
| 7 | 1. Replace Mixer. Is this action complete? | | Go to Step 5 | Go to Step 9 |
| 8 | 1. The fuel control system is operating normally. Refer to Symptoms Diagnosis 1. Disconnect all test equipment 2. 2. If you were sent to this routine by another diagnostic chart, retune to the previous diagnostic procedure. Is this action complete? | | System OK | |
| 9 | 1. Disconnect all test equipment 2. Start the engine 3. Using a liquid leak detection solution leak check any fuel system repairs made. Is this action complete? | | System OK | |

Fuel System Symptom Diagnostics

FUEL SYSTEM SYMPTOM DIAGNOSTICS

| Checks | Action |
|----------------------------|---|
| Before Using This Section | <p>Before using this section, you should have performed On Board Diagnostic (OBD) Check and determined that:</p> <ol style="list-style-type: none"> 1. The ECM and MIL are operating correctly. 2. There are no Diagnostic Trouble Codes (DTCs) stored, or a DTC exists but without a MIL. <p>Several of the following symptom procedures call for a careful visual and physical check. These checks are very important as they can lead to prompt diagnosis and correction of a problem.</p> |
| Fuel System Check | <ol style="list-style-type: none"> 1. Verify the customer complaint. 2. Locate the correct symptom table. 3. Check the items indicated under that symptom. 4. Operate the equipment under the conditions the symptom occurs. Verify HEGO switching between lean and rich. IMPORTANT! Normal HEGO switching indicates the fuel system is in closed loop and operating correctly at that time. 5. Take a data snapshot using the DST under the condition that the symptom occurs to review at a later time. |
| Visual and Physical Checks | <ul style="list-style-type: none"> • Check all ECM system fuses and circuit breakers. • Check the ECM ground for being clean, tight and in its proper location. • Check the vacuum hoses for splits, kinks and proper connections. • Check thoroughly for any type of leak or restriction. • Check for air leaks at all the mounting areas of the intake manifold sealing surfaces. • Check for proper installation of the mixer assembly. • Check for air leaks at the mixer assembly. <p>Check the ignition wires for the following conditions:</p> <ul style="list-style-type: none"> • Cracking • Hardening • Proper routing • Carbon tracking. <ul style="list-style-type: none"> • Check the wiring for the following items: proper connections, pinches or cuts. • The following symptom tables contain groups of possible causes for each symptom. The order of these procedures is not important. If the DST readings do not indicate a problem, then proceed in a logical order, easiest to check or most likely to cause the problem. |

INTERMITTENT

| Checks | Action |
|--|---|
| <p>DEFINITION: The problem may or may not turn ON the (MIL) or store a Diagnostic Trouble Code (DTC).</p> | |
| Preliminary Checks | Do not use the DTC tables. If a fault is an intermittent, the use of the DTC tables with this condition may result in the replacement of good parts. |
| Faulty Electrical Connections or Wiring | <p>Faulty electrical connections or wiring can cause most intermittent problems. Check the suspected circuit for the following conditions:</p> <ul style="list-style-type: none"> • Faulty fuse or circuit breaker, connectors poorly mated, terminals not fully seated in the connector (backed out). Terminals not properly formed or damaged. • Wire terminals poorly connected. • Terminal tension is insufficient. • Carefully remove all the connector terminals in the problem circuit in order to ensure the proper contact tension. • If necessary, replace all the connector terminals in the problem circuit in order to ensure the proper contact tension (except those noted as “Not Serviceable”). See section <i>Wiring Schematics</i>. • Checking for poor terminal to wire connections requires removing the terminal from the connector body. |
| Operational Test | If a visual and physical check does not locate the cause of the problem, operate the vehicle with the DST connected. When the problem occurs, an abnormal voltage or scan reading indicates a problem circuit. |
| Intermittent MIL Illumination | <p>The following components can cause intermittent MIL and no DTC(s):</p> <ul style="list-style-type: none"> • A defective relay. • Switch that can cause electrical system interference. Normally, the problem will occur when the faulty component is operating. • The improper installation of add on electrical devices, such as lights, 2-way radios, electric motors, etc. • The ignition secondary voltage shorted to a ground. • The MIL circuit or the Diagnostic Test Terminal intermittently shorted to ground. • The MIL wire grounds. |
| Loss of DTC Memory | <p>To check for the loss of the DTC Memory:</p> <ol style="list-style-type: none"> 1. Disconnect the TMAP sensor. 2. Idle the engine until the MIL illuminates. 3. The ECM should store a TMAP DTC which should remain in the memory when the ignition is turned OFF. If the TMAP DTC does not store and remain, the ECM is faulty. |

NO START

| Checks | Action |
|---|--|
| DEFINITION: The engine cranks OK but does not start. | |
| Preliminary Checks | None |
| ECM Checks | <p>Use the DST to :</p> <ul style="list-style-type: none"> • Check for proper communication with both the ECM • Check all system fuses engine fuse holder. Refer to <i>Engine Controls Schematics</i>. • Check battery power, ignition power and ground circuits to the ECM. Refer to <i>Engine Control Schematics</i>. Verify voltage and/or continuity for each. |
| Sensor Checks | <ul style="list-style-type: none"> • Check the TMAP sensor. • Check the cam angle sensor for output (RPM). |
| Fuel System Checks | <p>Important: A closed LPG manual fuel shut off valve will create a no start condition.</p> <ul style="list-style-type: none"> • Check for air intake system leakage between the mixer and the throttle body. Verify proper operation of the low pressure lock-off solenoids. • Verify proper operation of the fuel control solenoids. • Check the fuel system pressures. • Refer to the <i>LPG Fuel System Diagnosis</i>. • Check for proper mixer air valve operation. |
| Ignition System Checks | <p>Note: LPG being a gaseous fuel requires higher secondary ignition system voltages for the equivalent gasoline operating conditions.</p> <ol style="list-style-type: none"> 1. Check for the proper ignition voltage output with <i>J 26792</i> or the equivalent. 2. Verify that the spark plugs are correct for use with LPG. <p>Check the spark plugs for the following conditions:</p> <ul style="list-style-type: none"> • Wet plugs. • Cracks. • Wear. • Improper gap. • Burned electrodes. • Heavy deposits. • Check for bare or shorted ignition wires. • Check for loose ignition coil connections at the coil. |

NO START

| Checks | Action |
|--------------------------|--|
| Engine Mechanical Checks | <p>Important: The LPG Fuel system is more sensitive to intake manifold leakage than the gasoline fuel system.</p> <p>Check for the following:</p> <ul style="list-style-type: none">• Vacuum leaks.• Improper valve timing.• Low compression.• Improper valve clearance.• Worn rocker arms.• Broken or weak valve springs. <p>Worn camshaft lobes.</p> |
| Exhaust System Checks | <p>Check the exhaust system for a possible restriction:</p> <ul style="list-style-type: none">• Inspect the exhaust system for damaged or collapsed pipes:• Inspect the muffler for signs of heat distress or for possible internal failure.• Check for possible plugged catalytic converter. Refer to <i>Restricted Exhaust System Diagnosis</i>. |

HARD START

| Checks | Action |
|--|---|
| <p>DEFINITION: The engine cranks OK, but does not start for a long time. The engine does eventually run, or may start but immediately dies.</p> | |
| Preliminary Checks | Make sure the vehicle's operator is using the correct starting procedure. |
| Sensor Checks | <ul style="list-style-type: none"> • Check the Engine Coolant Temperature sensor with the DST. Compare the engine coolant temperature with the ambient air temperature on a cold engine. If the coolant temperature reading is more than 10 degrees greater or less than the ambient air temperature on a cold engine, check for high resistance in the coolant sensor circuit. Check the cam angle sensor. • Check the Throttle Position (TPS) and Foot Pedal Position (FPP) sensor connections. |
| Fuel System Checks | <p>Important: A closed LPG manual fuel shut off valve will create an extended crank OR no start condition.</p> <ul style="list-style-type: none"> • Verify the excess flow valve is not tripped or that the manual shut-off valve is not closed. <p>Check mixer assembly for proper installation and leakage.</p> <ul style="list-style-type: none"> • Verify proper operation of the low pressure lock-off solenoid. • Verify proper operation of the EPR. • Check for air intake system leakage between the mixer and the throttle body. Check the fuel system pressures. Refer to the <i>Fuel System Diagnosis</i>. |
| Ignition System Checks | <p>Note: LPG being a gaseous fuel requires higher secondary ignition system voltages for the equivalent gasoline operating conditions.</p> <ul style="list-style-type: none"> • Check for the proper ignition voltage output with J 26792 or the equivalent. • Verify that the spark plugs are the correct type and properly gapped. <p>Check the spark plugs for the following conditions:</p> <ul style="list-style-type: none"> • Wet plugs. • Cracks. • Wear. • Burned electrodes. • Heavy deposits • Check for bare or shorted ignition wires. • Check for moisture in the distributor cap. • Check for loose ignition coil connections. <p>Important:</p> <ol style="list-style-type: none"> 1. If the engine starts but then immediately stalls, check the cam angle sensor. 2. Check for improper gap, debris or faulty connections. |

HARD START

| Checks | Action |
|--------------------------|--|
| Engine Mechanical Checks | <p>Important: The LPG Fuel system is more sensitive to intake manifold leakage than the gasoline fuel supply system.</p> <p>Check for the following:</p> <ul style="list-style-type: none"> • Vacuum leaks • Improper valve timing • Low compression • Improper valve clearance. • Worn rocker arms • Broken or weak valve springs • Worn camshaft lobes. <p>Check the intake and exhaust manifolds for casting flash.</p> |
| Exhaust System Checks | <p>Check the exhaust system for a possible restriction:</p> <ul style="list-style-type: none"> • Inspect the exhaust system for damaged or collapsed pipes. • Inspect the muffler for signs of heat distress or for possible internal failure. <p>Check for possible plugged catalytic converter. Refer to <i>Restricted Exhaust System Diagnosis</i>.</p> |

CUTS OUT, MISSES

| Checks | Action |
|--|--|
| <p>DEFINITION: A surging or jerking that follows engine speed, usually more pronounced as the engine load increases, but normally felt below 1500 RPM. The exhaust has a steady spitting sound at idle, low speed, or hard acceleration for the fuel starvation that can cause the engine to cut-out.</p> | |
| Preliminary Checks | None |
| Ignition System Checks | <ol style="list-style-type: none"> 1. Start the engine. 2. Check for proper ignition output voltage with spark tester J 26792. 3. Check for a cylinder misfire. 4. Verify that the spark plugs are the correct type and properly gapped. <p>Remove the spark plugs and check for the following conditions:</p> <ul style="list-style-type: none"> • Insulation cracks. • Wear. • Improper gap. • Burned electrodes. • Heavy deposits. <p>Visually/Physically inspect the secondary ignition for the following:</p> <ul style="list-style-type: none"> • Ignition wires for arcing and proper routing. • Cross-firing. • Ignition coils for cracks or carbon tracking |
| Engine Mechanical Checks | <p>Perform a cylinder compression check. Check the engine for the following:</p> <ul style="list-style-type: none"> • Improper valve timing. • Improper valve clearance. • Worn rocker arms. • Worn camshaft lobes. • Broken or weak valve springs. • Check the intake and exhaust manifold passages for casting flash. |
| Fuel System Checks | <p>Check the fuel system:</p> <ul style="list-style-type: none"> • Plugged fuel filter. • Low fuel pressure, etc. Refer to <i>LPG Fuel System Diagnosis</i>. • Check the condition of the wiring to the low pressure lock-off solenoid. |
| Additional Check | <p>Check for Electromagnetic Interference (EMI), which may cause a misfire condition. Using the DST, monitor the engine RPM and note sudden increases in rpms displayed on the scan tool but with little change in the actual engine rpm. If this condition exists, EMI may be present. Check the routing of the secondary wires and the ground circuit.</p> |

HESITATION, SAG, STUMBLE

| Checks | Action |
|---|---|
| <p>DEFINITION: The engine has a momentary lack of response when putting it under load. The condition can occur at any engine speed. The condition may cause the engine to stall if it's severe enough.</p> | |
| Preliminary Checks | None. |
| Fuel System Checks | <ul style="list-style-type: none"> • Check the fuel pressure. Refer to <i>LPG Fuel System Diagnosis</i>. • Check for low fuel pressure during a moderate or full throttle acceleration. If the fuel pressure drops below specification, there is possibly a faulty low pressure regulator or a restriction in the fuel system. • Check the TMAP sensor response and accuracy. • Check Shut-Off electrical connection. • Check the mixer air valve for sticking or binding. • Check the mixer assembly for proper installation and leakage. Check the EPR. |
| Ignition System Checks | <p>Note: LPG being a gaseous fuel requires higher secondary ignition system voltages for the equivalent gasoline operating conditions. If a problem is reported on LPG and not gasoline, do not discount the possibility of a LPG only ignition system failure and test the system accordingly.</p> <ul style="list-style-type: none"> • Check for the proper ignition voltage output with <i>J 26792</i> or the equivalent. Verify that the spark plugs are the correct type and properly gapped. • Check for faulty spark plug wires. • Check for fouled spark plugs. |
| Additional Check | <ul style="list-style-type: none"> • Check for manifold vacuum or air induction system leaks. • Check the alternator output voltage. |

BACKFIRE

| Checks | Action |
|---|---|
| <p>DEFINITION: The fuel ignites in the intake manifold, or in the exhaust system, making a loud popping noise.</p> | |
| Preliminary Check | None. |
| Ignition System Checks | <p>Important! LPG, being a gaseous fuel, requires higher secondary ignition system voltages for the equivalent gasoline operating conditions. The ignition system must be maintained in peak condition to prevent backfire.</p> <ul style="list-style-type: none"> • Check for the proper ignition coil output voltage using the spark tester J26792 or the equivalent. • Check the spark plug wires by connecting an ohmmeter to the ends of each wire in question. If the meter reads over 30,000 ohms, replace the wires. • Check the connection at ignition coil. • Check for deteriorated spark plug wire insulation. <p>Remove the plugs and inspect them for the following conditions:</p> <ul style="list-style-type: none"> • Wet plugs. • Cracks. • Wear. • Improper gap. • Burned electrodes. • Heavy deposits. |
| Engine Mechanical Check | <p>Important! The LPG Fuel system is more sensitive to intake manifold leakage than a gasoline fuel supply system.</p> <p>Check the engine for the following:</p> <ul style="list-style-type: none"> • Improper valve timing. • Engine compression. • Manifold vacuum leaks. • Intake manifold gaskets. • Sticking or leaking valves. • Exhaust system leakage. • Check the intake and exhaust system for casting flash or other restrictions. |
| Fuel System Checks | Perform a fuel system diagnosis. Refer to <i>LPG Fuel System Diagnosis</i> . |

LACK OF POWER, SLUGGISHNESS, OR SPONGINESS

| Checks | Action |
|---|---|
| DEFINITION: <i>The engine delivers less than expected power.</i> | |
| Preliminary Checks | <ul style="list-style-type: none"> • Refer to the <i>LPG Fuel system OBD System Check</i>. • Compare the customer's vehicle with a similar unit to verify customer has an actual problem. <i>Do not compare the power output of the vehicle operating on LPG to a vehicle operating on gasoline as the fuels do have different drive feel characteristics.</i> • Remove the air filter and check for dirt or restriction. • Check the vehicle transmission. • Refer to the OEM transmission diagnostics. |
| Fuel System Checks | <ul style="list-style-type: none"> • Check for a restricted fuel filter, contaminated fuel, or improper fuel pressure. Refer to <i>LPG Fuel System Diagnosis</i>. • Check for the proper ignition output voltage with the spark tester <i>J 26792</i> or the equivalent. • Check for proper installation of the mixer assembly. Check all air inlet ducts for condition and proper installation. • Check for fuel leaks between the EPR and the mixer. • Verify that the LPG tank manual shut-off valve is fully open. • Verify that liquid fuel (not vapor) is being delivered to the EPR. |
| Sensor Checks | <ul style="list-style-type: none"> • Check the Heated Exhaust Gas Oxygen Sensors (HEGO) for contamination and performance. Check for proper operation of the TMAP sensor. • Check for proper operation of the TPS and FPP sensors. |
| Exhaust System Checks | <p>Check the exhaust system for a possible restriction:</p> <ul style="list-style-type: none"> • Inspect the exhaust system for damaged or collapsed pipes. • Inspect the muffler for signs of heat distress or for possible internal failure. • Check for possible plugged catalytic converter. |
| Engine Mechanical Check | <p>Check the engine for the following:</p> <ul style="list-style-type: none"> • Engine compression. • Valve timing. • Improper or worn camshaft. • Refer to <i>Engine Mechanical</i> in the Service Manual. |
| Additional Check | <ul style="list-style-type: none"> • Check the ECM grounds for being clean, tight, and in their proper locations. • Check the alternator output voltage. <p>If all procedures have been completed and no malfunction has been found, review and inspect the following items:</p> <ul style="list-style-type: none"> • Visually and physically, inspect all electrical connections within the suspected circuit and/or systems. • Check the DST data. |

ROUGH, UNSTABLE, OR INCORRECT IDLE, STALLING

| Checks | Action |
|---|---|
| <p>DEFINITION: The engine runs unevenly at idle. If severe enough, the engine may shake.</p> | |
| Preliminary Check | None. |
| Sensor Checks | <p>Check the Heated Exhaust Gas Oxygen Sensors (HEGO) performance:</p> <ul style="list-style-type: none"> • Check for silicone contamination from fuel or improperly used sealant. If contaminated, the sensor may have a white powdery coating result in a high but false signal voltage (rich exhaust indication). The ECM will reduce the amount of fuel delivered to the engine causing a severe drivability problem. <p>Check the Temperature Manifold Absolute Pressure (TMAP) sensor response and accuracy.</p> |
| Fuel System Checks | <ul style="list-style-type: none"> • Check for rich or lean symptom that causes the condition. • Drive the vehicle at the speed of the complaint. • Monitoring the oxygen sensors will help identify the problem. • Check for a sticking mixer air valve. • Verify proper operation of the EPR. • Perform a cylinder compression test. Refer to <i>Engine Mechanical</i> in the Service Manual. • Check the EPR fuel pressure. Refer to the <i>LPG Fuel System Diagnosis</i>. • Check mixer assembly for proper installation and connection. |
| Ignition System Checks | <ul style="list-style-type: none"> • Check for the proper ignition output voltage using the spark tester J26792 or the equivalent. • Verify that the spark plugs are the correct type and properly gapped. <p>Remove the plugs and inspect them for the following conditions:</p> <ul style="list-style-type: none"> • Wet plugs. • Cracks. • Wear. • Improper gap. • Burned electrodes. • Blistered insulators. • Heavy deposits. <p>Check the spark plug wires by connecting an ohmmeter to the ends of each wire in question. If the meter reads over 30,000 ohms, replace the wires.</p> |
| Additional Checks | <p>Important: The LPG Fuel system is more sensitive to intake manifold leakage than the gasoline fuel supply system.</p> <ul style="list-style-type: none"> • Check for vacuum leaks. Vacuum leaks can cause a higher than normal idle and low throttle angle control command. • Check the ECM grounds for being clean, tight, and in their proper locations. Check the battery cables and ground straps. They should be clean and secure. Erratic voltage may cause all sensor readings to be skewed resulting in poor idle quality. |

ROUGH, UNSTABLE, OR INCORRECT IDLE, STALLING

| Checks | Action |
|-------------------------|---|
| Engine Mechanical Check | Check the engine for: <ul style="list-style-type: none">• Broken motor mounts.• Improper valve timing.• Low compression.• Improper valve clearance.• Worn rocker arms.• Broken or weak valve springs.• Worn camshaft lobes. |

Electrical Section

NOTE: YOU CAN OBTAIN A FULL SIZE ELECTRONIC WIRE DIAGRAM BY CONTACTING THE OEM.

SLAVE HARNESS

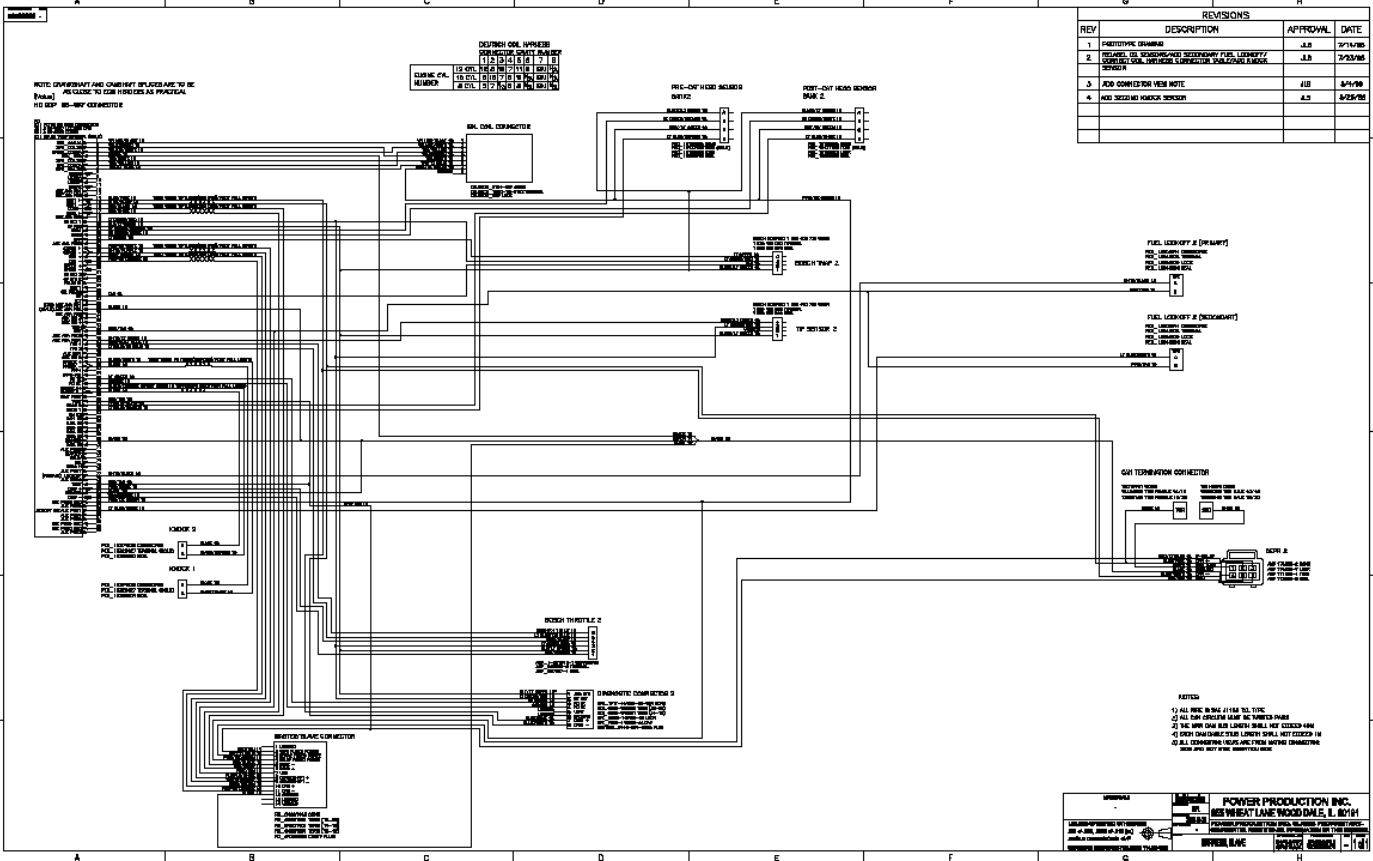

MASTER HARNESS V-SERIES

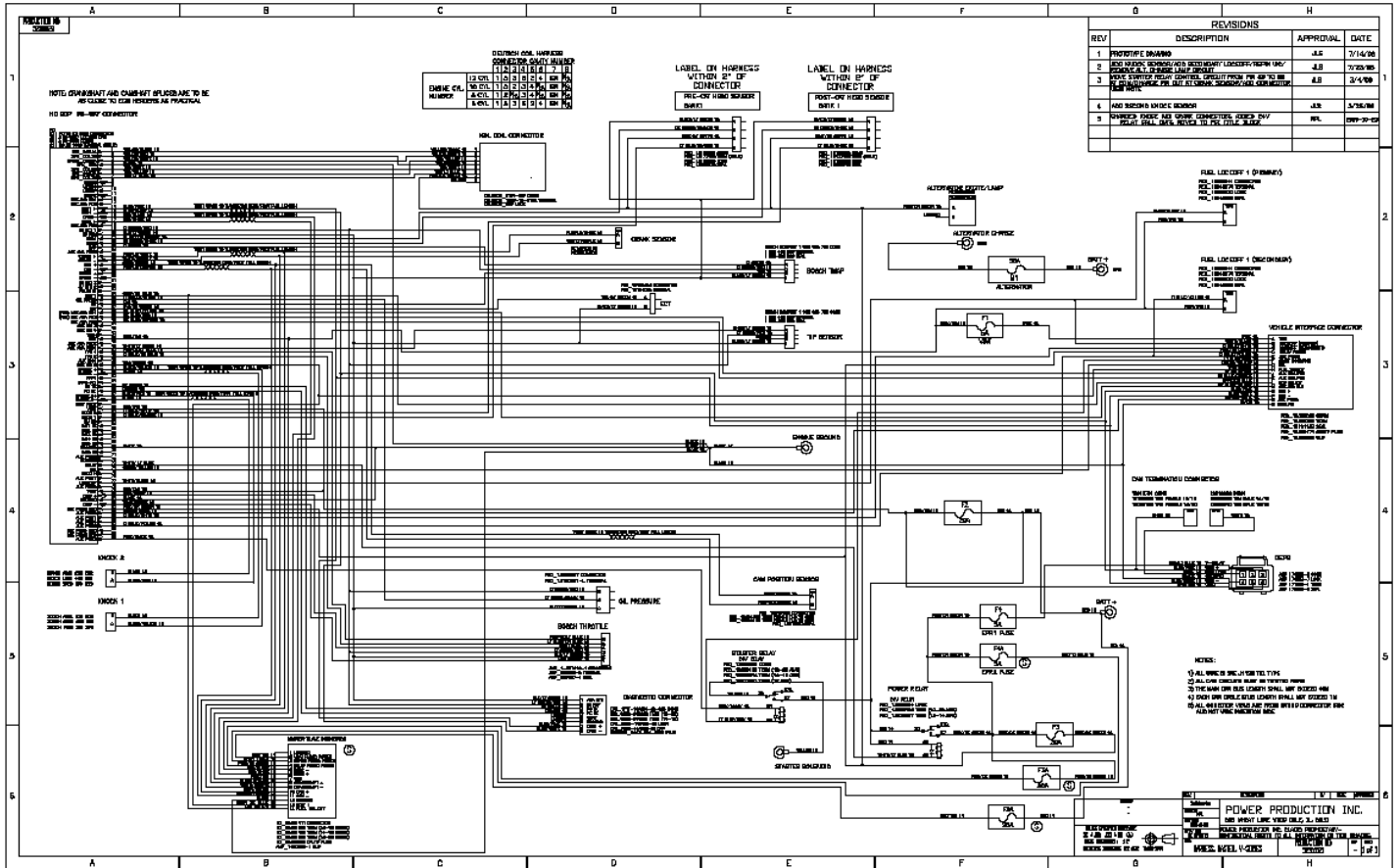

11L MAIN HARNESS

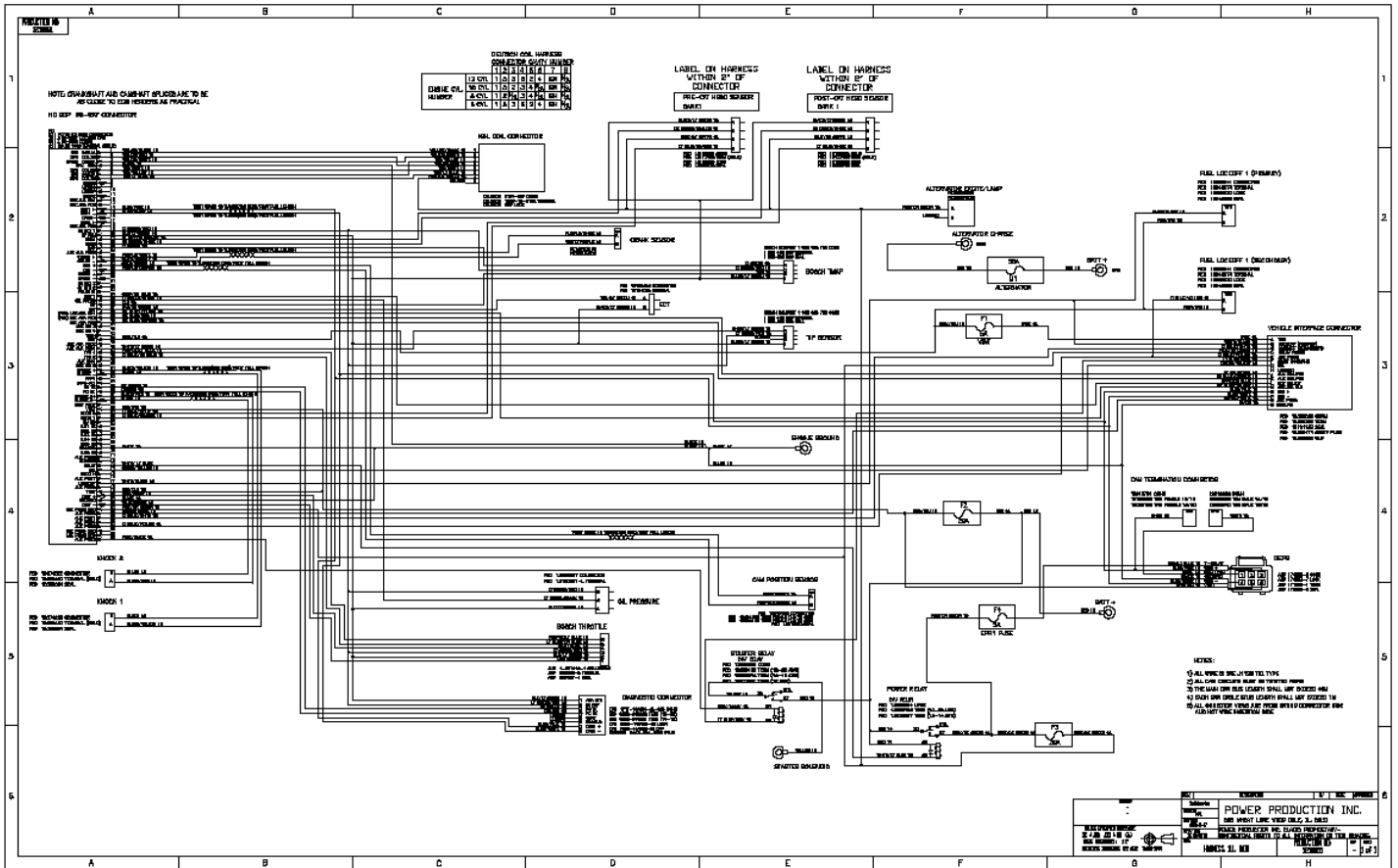

8L MAIN HARNESS

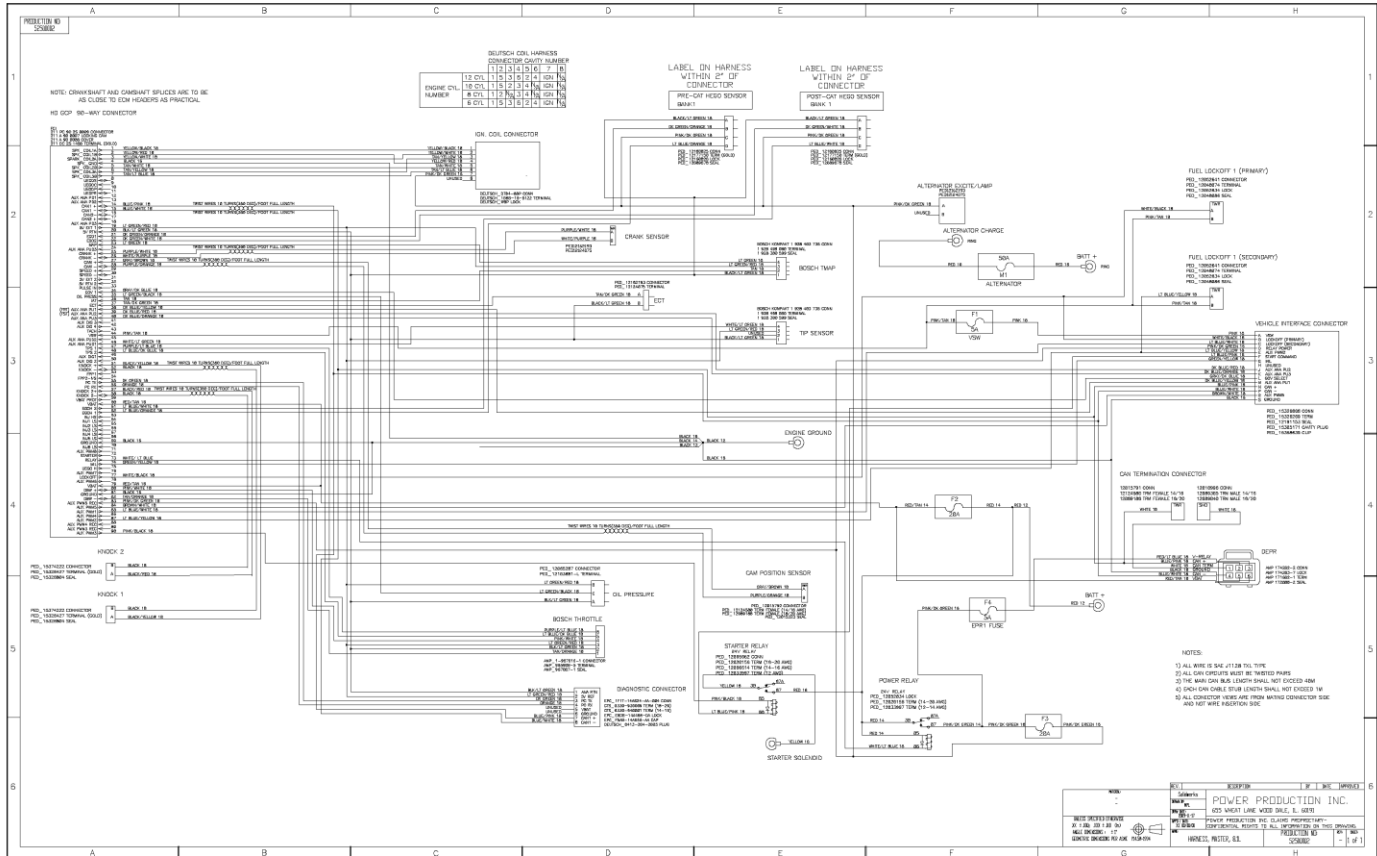

Diagnostic Scan Tool (DST)

CONTENTS

- Installation of the DST package to a personal computer (PC).
- Software login and password functionality.
- DST service pages.
- Updating the ECM calibration using a MOT file.
- DTC pages.

Examples and snapshots used in this manual are based off of the initial DST tool release as of July, 2007. This tool is frequently updated and the illustrations may vary depending on the changes included in any updated DST display Interface. For example, the Electronic Pressure Regulator (EPR) may be referred to as the “megajector.” Terms, names and descriptions of parts and servicing procedures will be updated based on trade, brand, or common description to more accurately describe the part or service procedure.

DST INSTALLATION INSTRUCTIONS

Before installing the DST software, please be sure your computer meets the minimum system requirements.

Supported operating systems are:

- Windows Vista
- Windows XP
- Windows 2000

Minimum processor speed:

- Pentium II 450 MHz
- Pentium III 1.0 GHz for Windows Vista

Minimum RAM requirement:

- Windows Vista 512 MB
- Windows XP 256 MB
- Windows 2000 128 MB

* At least one available RS232 serial or USB port.

* ECOM cable supports USB port only.

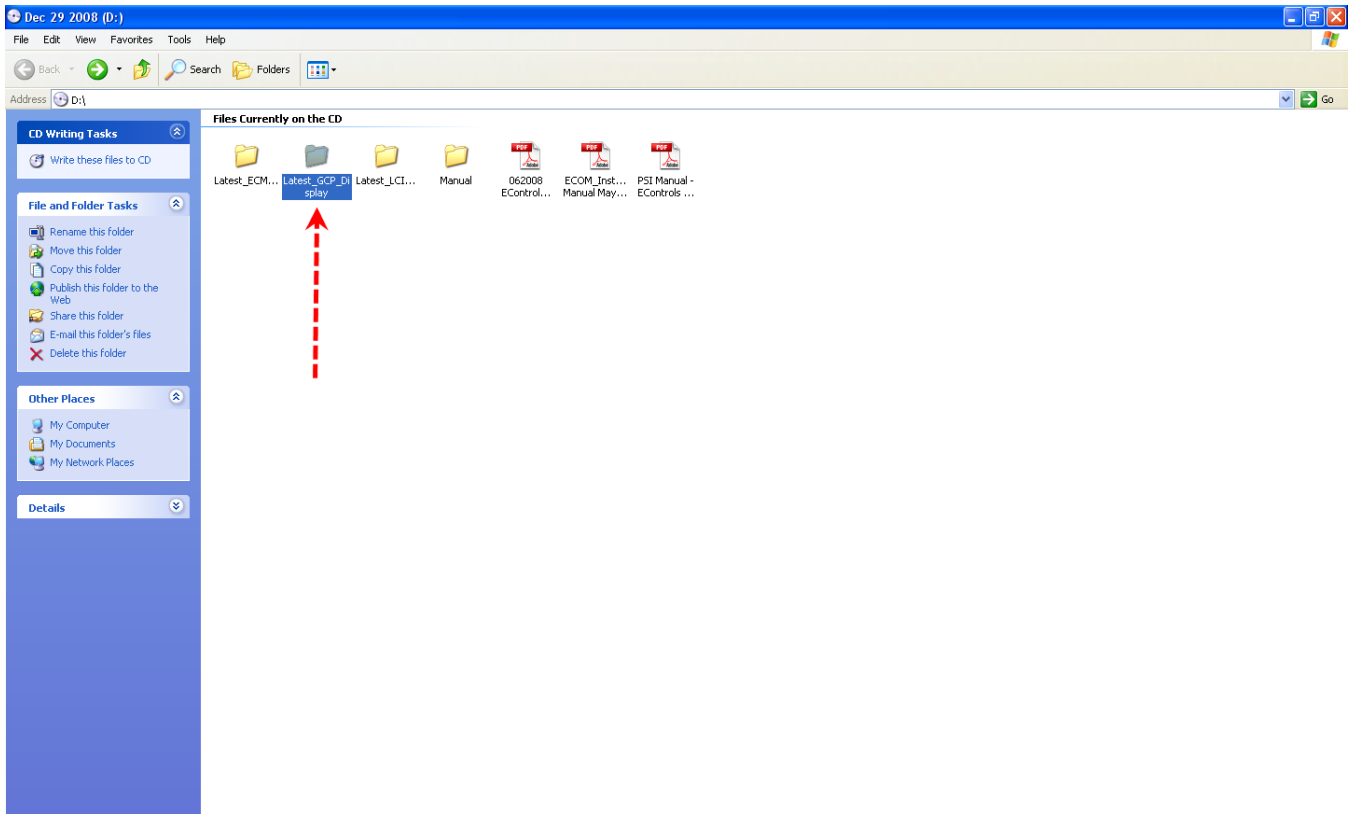

- Insert the CD into your computer and select **LATEST_GCP_DISPLAY**

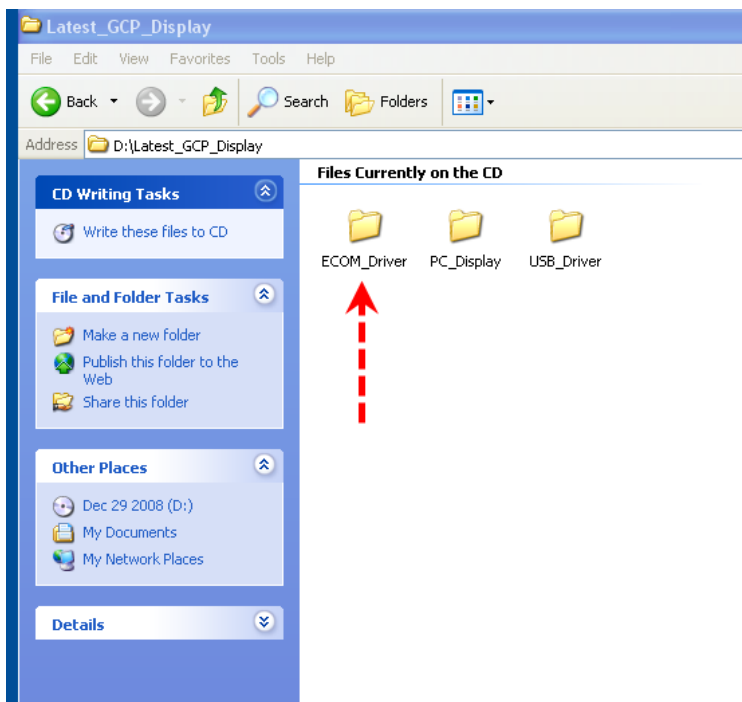

- Open the **ECOM_Driver** Folder

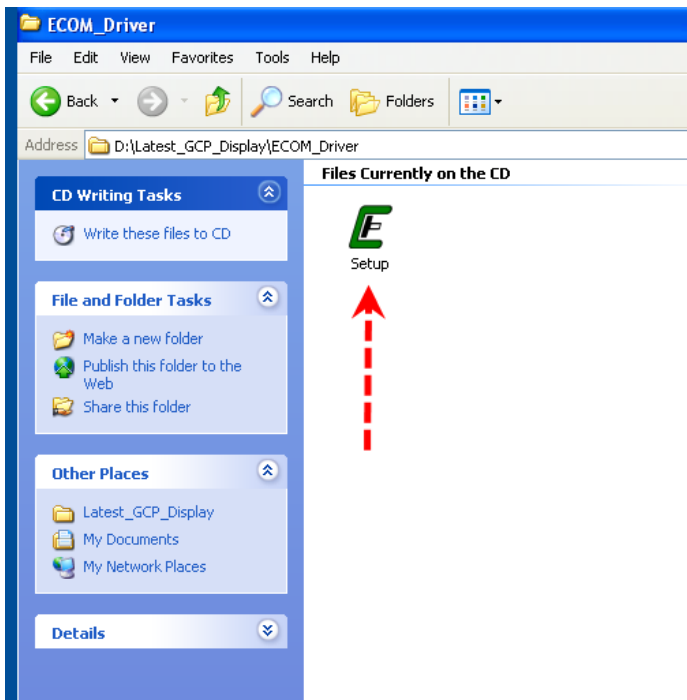

- Double Click the setup.exe file - - - > This will launch the installation wizard
- Select "NEXT" until you finish the installation as shown below

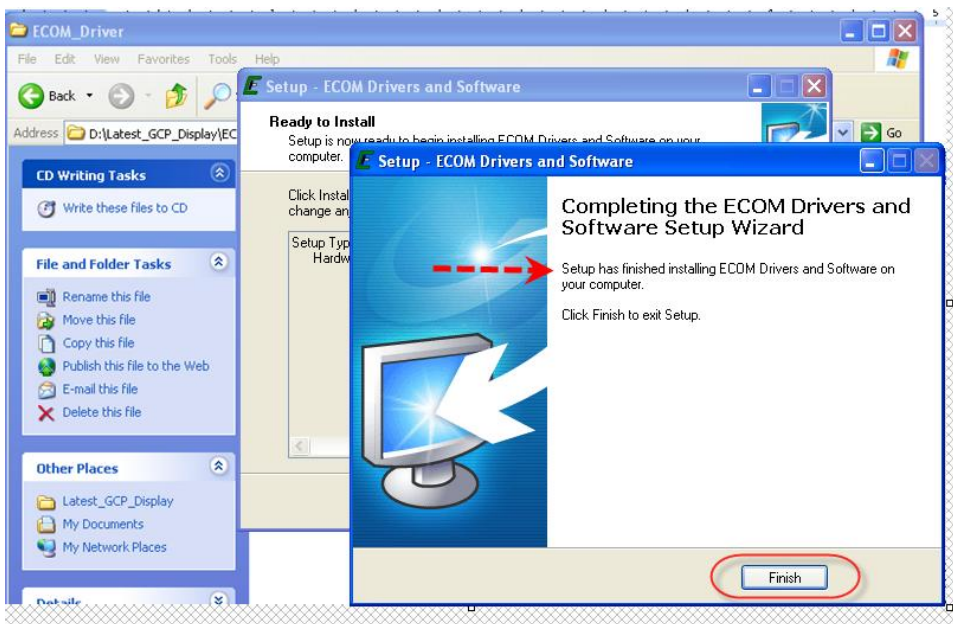

- Return to the **LATEST_GCP_DISPLAY** folder

- Select the PC Display folder

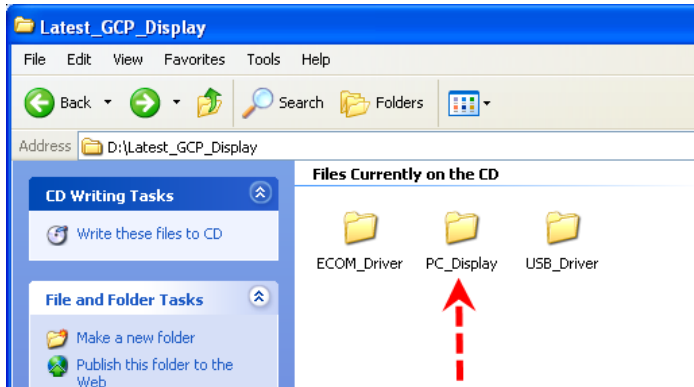

- Select the GCP Display icon

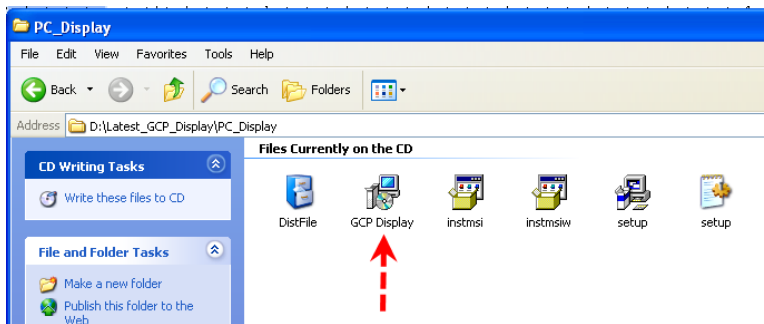

- Select the GCP Display icon - - - > This will launch the installation wizard

- Select NEXT until it says you are finish

- Restart your PC

- Go to the START button on the lower left corner and find the GCP Display Program

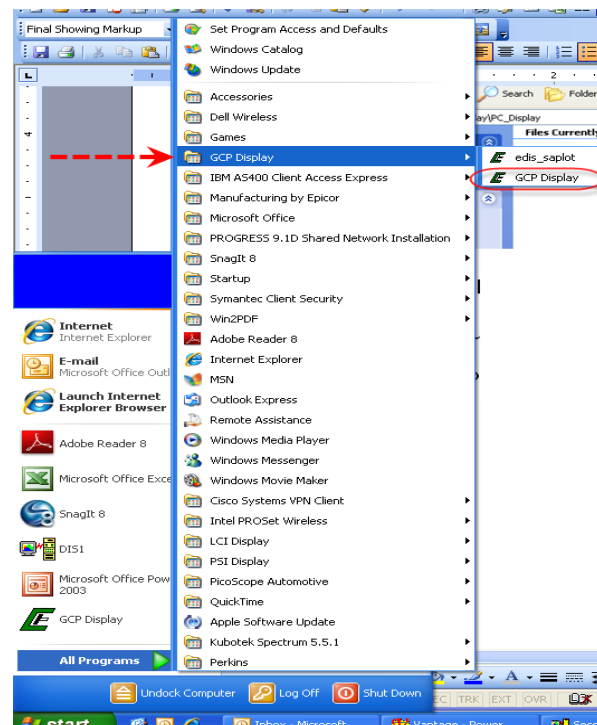

PASSWORD LOGIN

Figure 1 shows the password dialog box, which is displayed when a software session begins. Login can be accomplished in two ways.

1. Enter an “All S/N Password” which is a password applicable to all ECMs of a given original equipment manufacture (OEM).
2. Enter a “Single S/N Password” and corresponding ECM serial number for a single ECM. A Single Serial Number password is unique to a specific ECM serial number and permits authorized service personnel to make changes or view information for a specific ECM.
3. In most instances the top “all” serial number boxes should be used for password entry. In this case, do not check the single serial number box. Each password is a 16-character alphanumeric string specific to each Spectrum customer and determines which pages and variables are visible through the software. Passwords are assigned by the OEM support group and may change periodically. Check the “save password” box to automatically retain the password for future use.

Note: The password is printed on the CD disk. If it does not have a password or you have questions please contact the OEM.

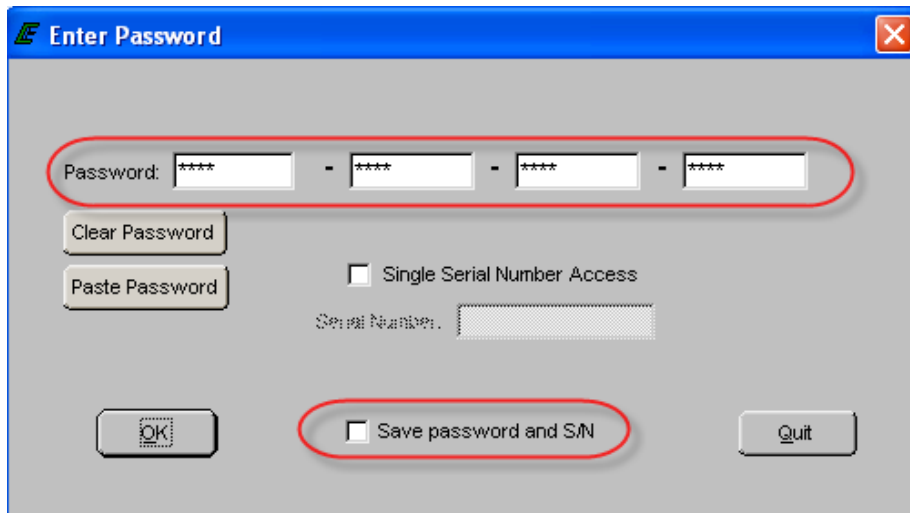

Figure 1: Populated Password Dialog Box

PASSWORD DIALOG BOX FUNCTIONS

- **Clear Password Button** Erases the current password from the password field.
- **Paste Password Button** Allows the user to copy a 16-character string from any word processor and paste the string in the password field.
- **Single Serial Number Access Checkbox** Tells the software that the password is applicable for single serial number access.
- **Serial Number Field** Only applicable when Single Serial Number Access Checkbox is checked. The entry field must be populated for the 6-digit serial number for which the Single Serial Number Access password applies (NOTE: Leading zeros included in the serial number are not required).
- **Save Password and S/N Checkbox** Retains the password, and serial number (if applicable) for the next software session.

Should an invalid password be entered, the error prompt shown in figure (2) will be displayed and the software will not load. This prompt signifies the following:

- The All S/N password is invalid.
- The Single S/N password is incorrect for the Single Serial Number entered.
- An All S/N password is entered for Single Serial Number use.
- The Single Serial Number password is valid; however, the Single Serial Number Access Check-box is not checked.



Figure 2: Password Error Prompt

If the Single S/N password entered is correct for the software but does not match the entered S/N of the targeted ECM, the prompt in *Figure 3* will be displayed.

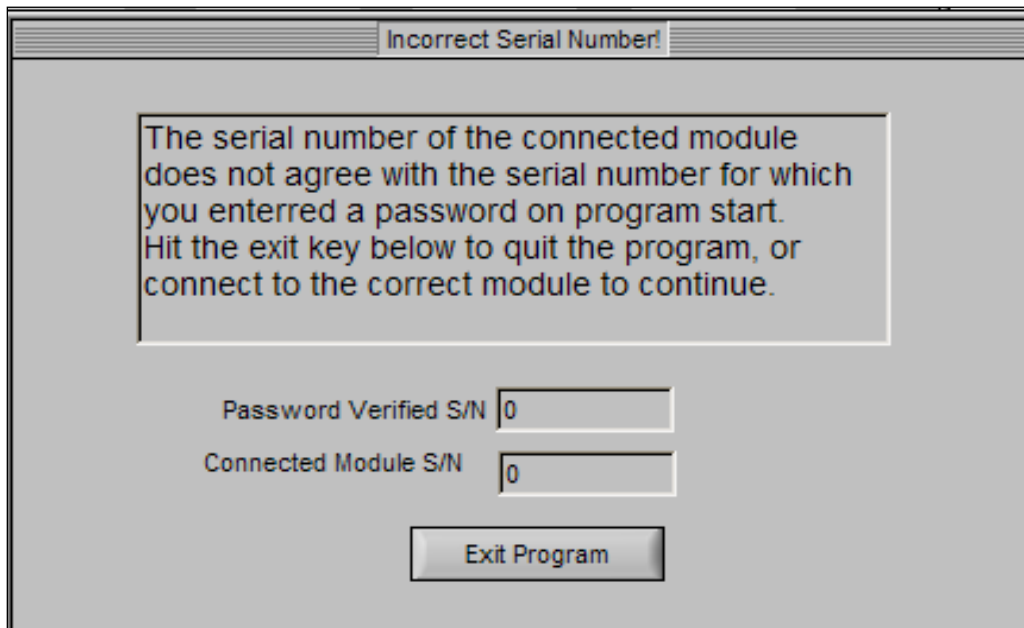

Figure 3: Incorrect Serial Number Message

Figure 4 shows the communication status if a valid software password is entered when attempting to connect to an ECM with a different key. In this instance the software will load but will not connect to the target (ECM).

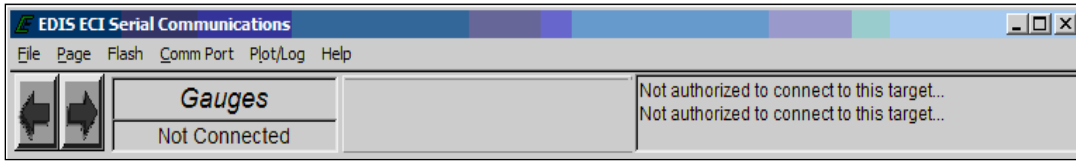
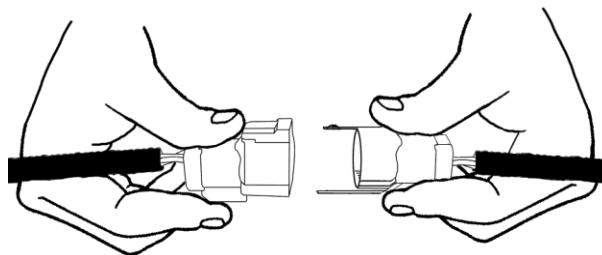

Figure 4: Not Authorized to Connect Message

In the event you receive this error message call your OEM support group for more information.

CONNECTING THE PC TO THE ENGINE WIRE HARNESS



Connecting the DST cable

A laptop computer, with the diagnostic cable and software is the required tool for performing proper diagnostic testing of the fuel system. It is also used to monitor sensor and actuator values and to read and clear Diagnostic Trouble codes. The DST software also performs several special tests.

- Connect the system diagnostic cable to the USB port on the back of the computer.
- Connect the diagnostic cable to the DLC (diagnostic link connector) labeled in the electrical schematic. The DLC is located on the engine harness. The new 8 pin DLC requires the use of the 4 to 8 pin adapter.
- Turn the computer ON.
- Start Windows.
- From the start menu select Programs → NGE GCP Display → NGE GCP Display
- Place the ignition key in the ON position.

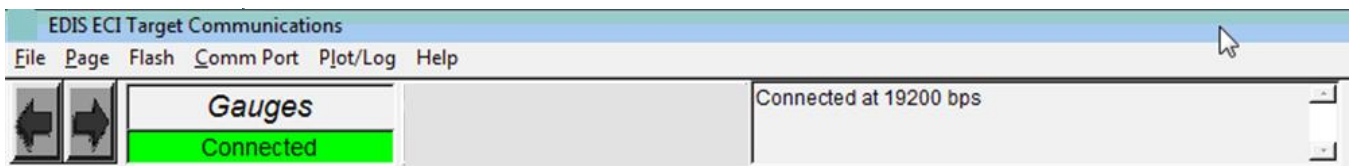

Within several seconds the system Gauge screen should now appear and a green banner in the upper left hand will read “Connected.”

- Connecting to the PC using the ECOM cable

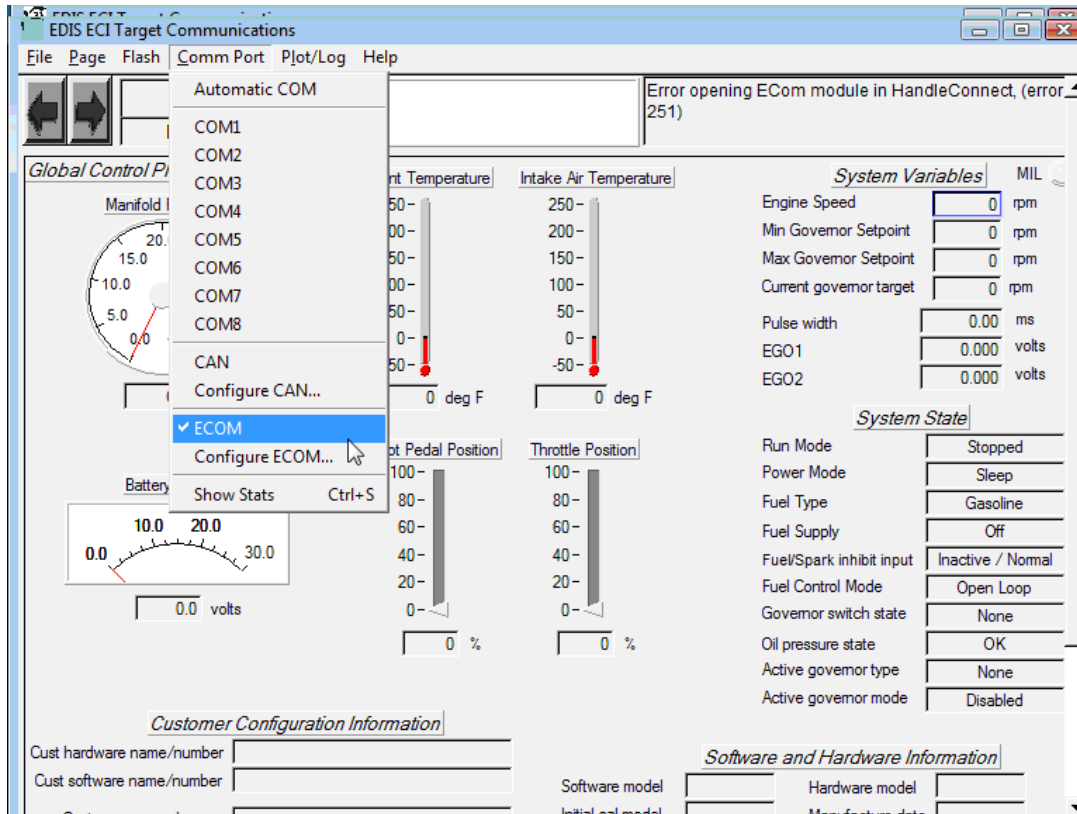

- To connect using the ECOM cable you must select ECOM from the COM Port drop down menu.

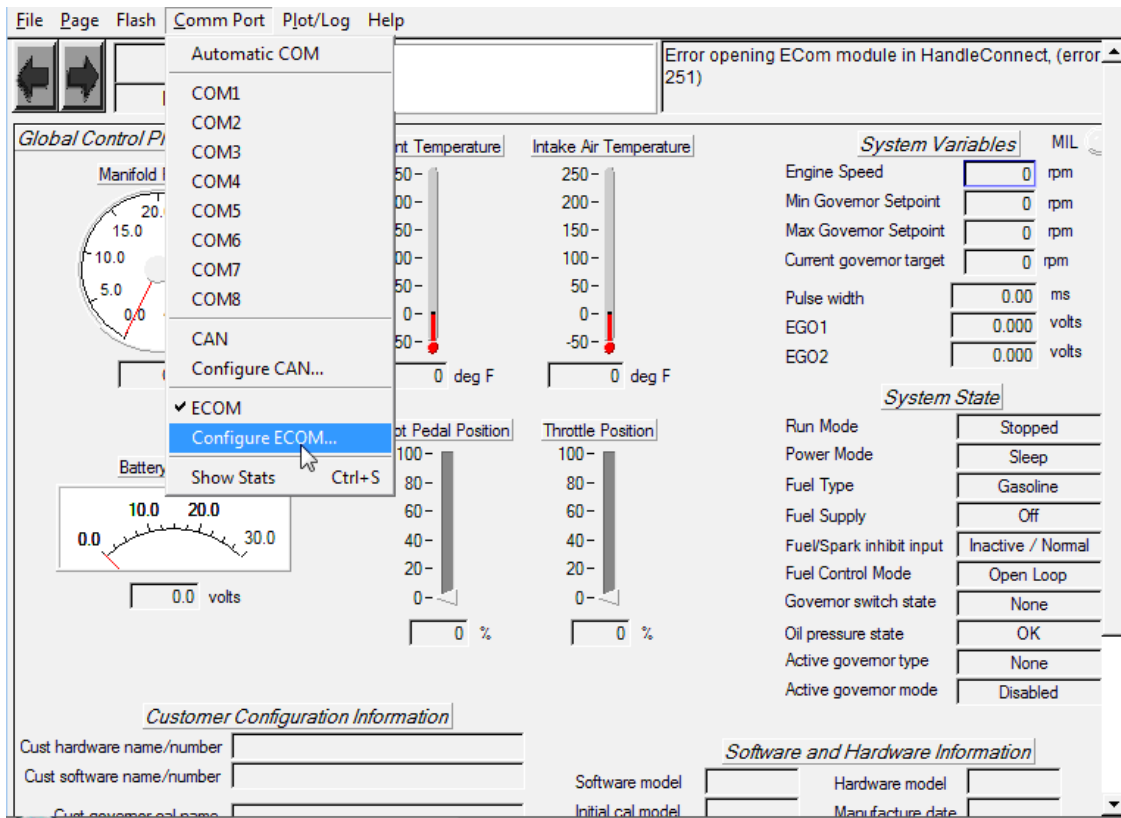

- You will now need to configure the ECOM communication protocol.

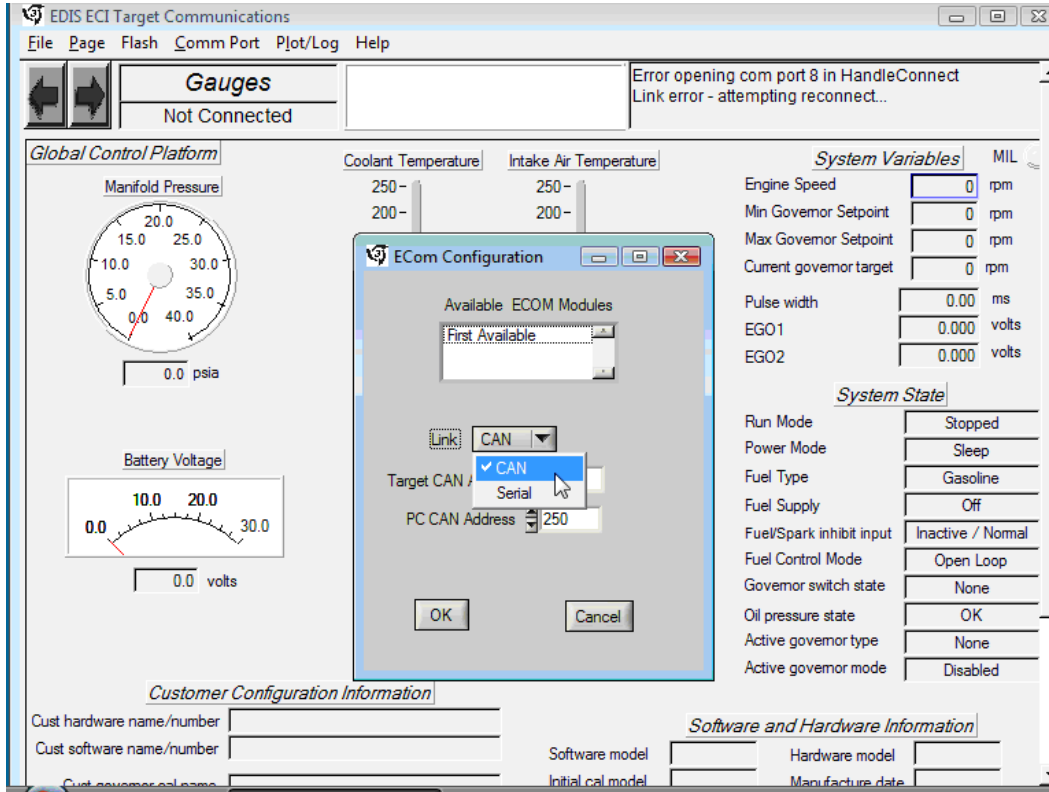

- Select the CAN for systems with CAN enabled or serial for all others. Then select OK. You are now ready to connect using the ECOM USB DLC cable.

DST SERVICE PAGES

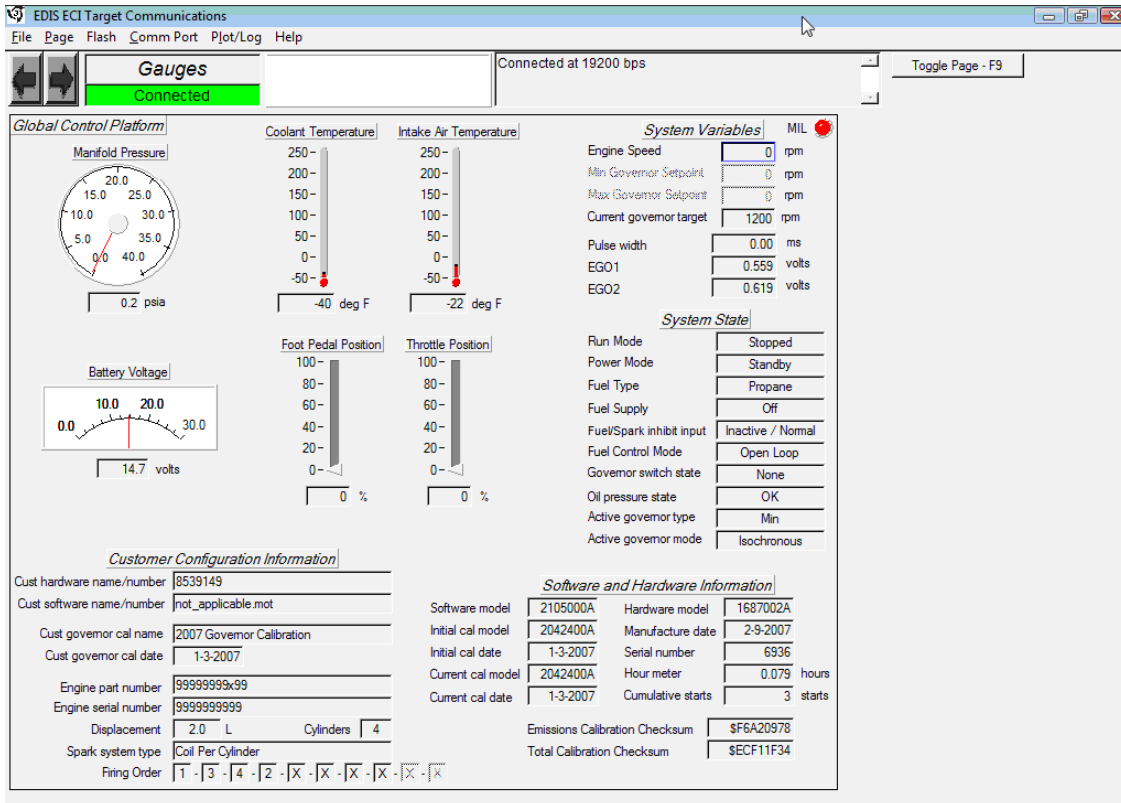

Gauge Page

Provides system data in large easy to read displays. Displays ECM configuration information for the ECM software, hardware, serial numbers and calibration dates.

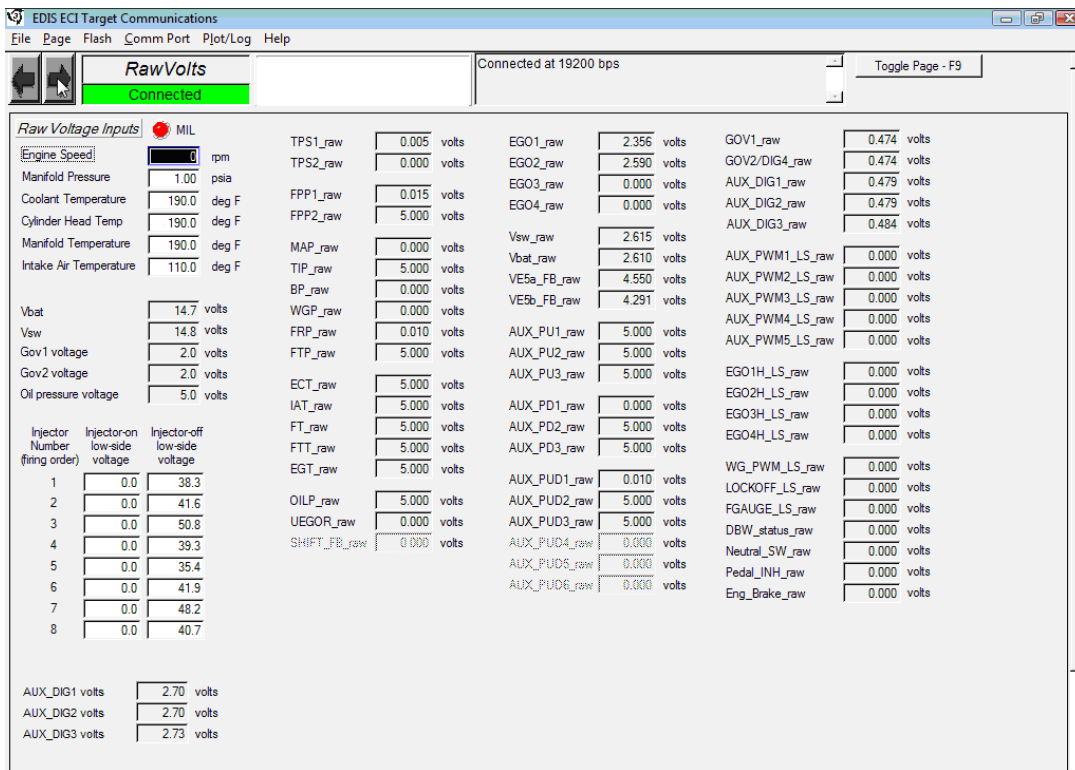

Raw Volts Page

The raw volts page displays the sensor inputs and outputs in a raw voltage format. This page is most commonly used to check values in the diagnostic trouble shooting charts.

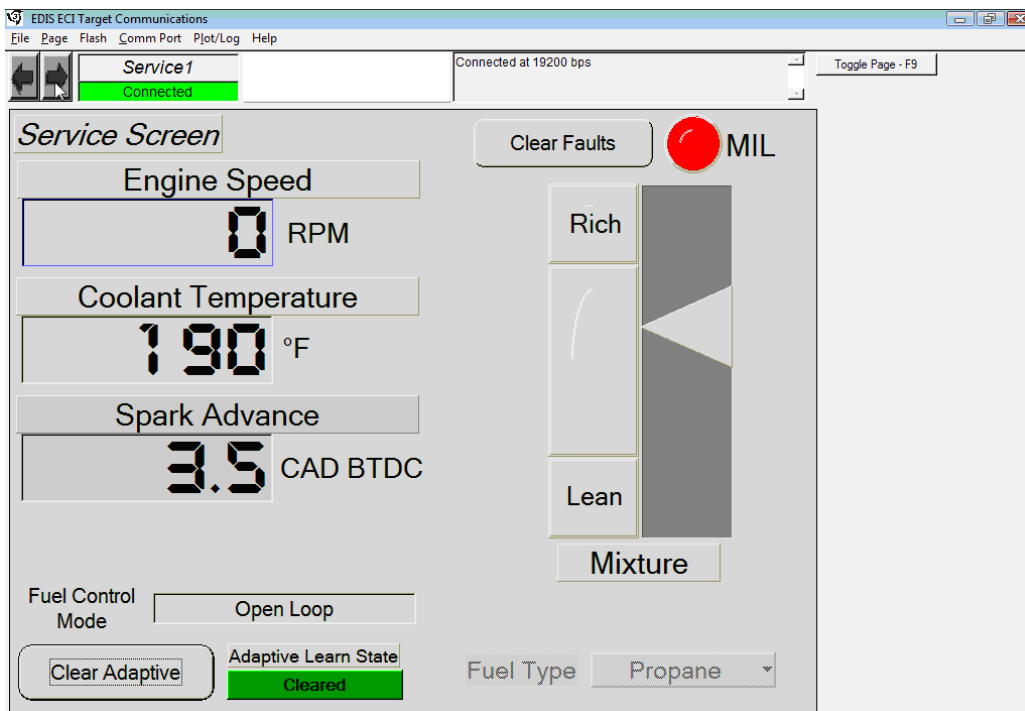

Service 1

The Service 1 screen is used to clear the adaptive learn, shows the MIL status and provides a display for rpm, coolant temperature and spark advance. It also provides a large display to monitor the closed loop mixture control.

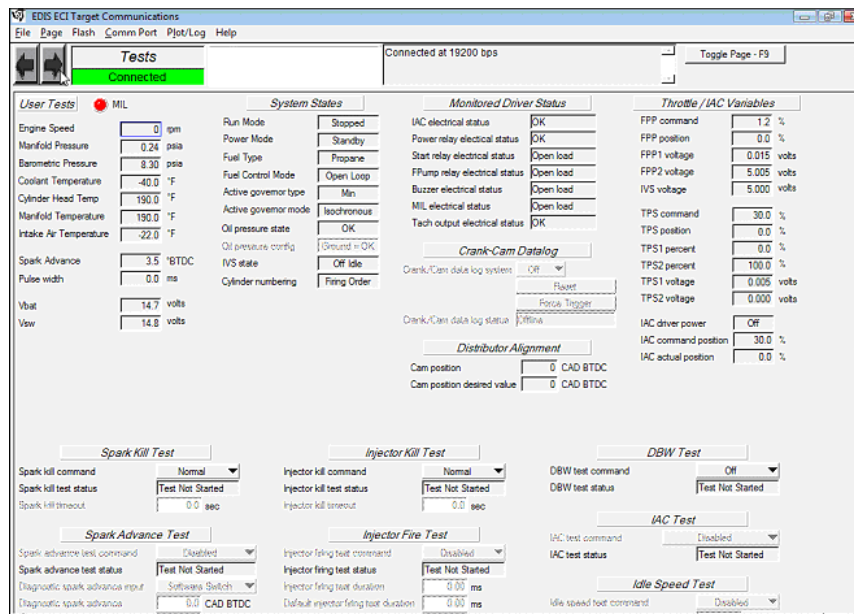

Tests Page

Provides diagnostic information voltages and sensor outputs and includes diagnostic engine tools such as spark and injector kill controls. Please note that not all features are available for all applications. The disabled item menus are grayed out or rendered inoperative.

SPARK KILL

The spark kill mode allows the technician to disable the ignition on individual cylinders. If the Spark Kill diagnostic mode is selected with the engine running below 1000 rpm, the minimum throttle command will lock into the position it was in when the test mode was entered. If the Spark System Test mode is selected with the engine running above 1000 rpm, the throttle will continue to operate normally. Disabling Ignition Outputs to disable the ignition system for an individual cylinder, use the mouse to highlight the “Spark Kill” button and select the desired coil. The spark output can be re-enabled by using the mouse to highlight the “Spark Kill” button and selecting “Normal.” If the engine is running below 1000 rpm, the spark output will stay disabled for 15 seconds and then re-set. If the engine is running above 1000 rpm, the spark output will stay disabled for 5 seconds and then re-set. This test mode has a timeout of 10 minutes. Record the rpm drop related to each spark output disabled. The spark outputs are arranged in the order which the engine fires, not by cylinder number.

INJECTOR KILL

The Injector Kill mode is used to disable individual fuel injectors. If the Injector Kill mode is selected with the engine running below 1000 rpm, the minimum throttle command will lock into the position it was in when the test mode was entered. If the Injector Kill mode is selected with the engine running above 1000 rpm, the throttle will continue to operate normally. To disable an injector, use the mouse to select the desired injector. The word “Normal” will change to the Injector you have selected. The injector driver can be re-enabled by selecting again. If the engine is running below 1000 rpm, the injector driver will stay disabled for 15 seconds and then re-

set. If the engine is running above 1000 rpm, the injector driver will stay disabled for 5 seconds and then re-set. Record the change in rpm while each driver is disabled.

DBW TEST MODE

The DBW (Drive by Wire) test mode allows the technician to control the throttle directly with the foot pedal or throttle input and is used during the diagnostic routines specified for FPP and TPS for Spectrum systems that use DBW control. FPP position displays the current position of the foot pedal as a percentage. FPP volts display the voltage which the ECM is reading from the FPP sensor. TPS Command displays the commanded throttle position expressed as a percentage, which is being sent to the throttle. TPS Position is the actual percent of throttle opening being sent to the ECM from the throttle. TPS volts display the actual TPS signal voltage the ECM is receiving from the throttle. To select this test mode the engine must be off and the key must be in the ON position.

EXTERNAL POWER TEST

The external power test manually activates relays (relay power, fuel pump, and drive-by wire power) controlled by the ECM while the engine is in the “Stopped” or “Running” states. Reverts to normal operation if “Automatic” state is selected or ignition voltage is cycled from high to low.

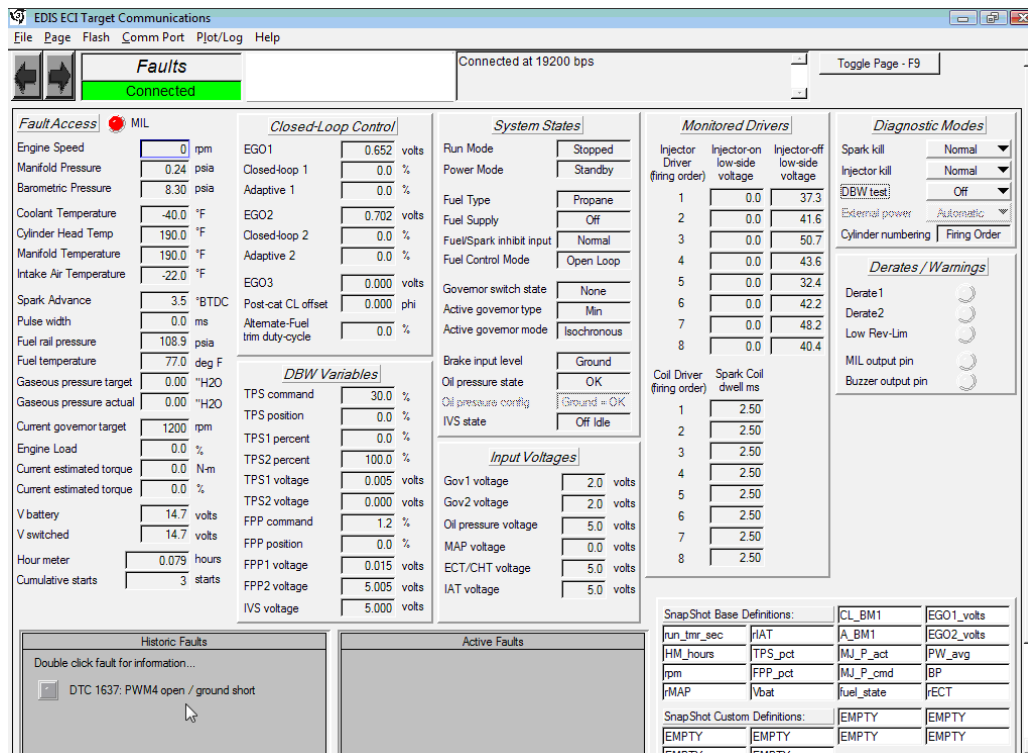

Faults Page

Stores DTC codes that may have occurred in the past (Historic Faults) or current set codes (Active Faults). Includes useful system voltages and sensor readings used while working with the fuel and emission trouble shooting charts. Shows power derate mode status. To erase a historic DTC code, double click on the code with the left mouse button. Then choose to “Clear All Faults.”

PLOT/LOG MENU FUNCTIONS

The Plot/Log menu allows the user to graphically plot or numerically log variables that have been tagged for plotting/logging. To plot or log variables, a tag must be assigned to each variable of interest. A variable is tagged for plotting/logging through a single right-mouse click in the variable's vicinity. Once a variable has been tagged for plotting/logging, it is highlighted in green.

Figure 5 shows an example of variables that have been tagged. A maximum of twenty (20) variables may be tagged for logging and a maximum of ten (10) variables may be tagged for plotting. The maximum achievable sample frequency/minimum period is dependent on the number of variables tagged.

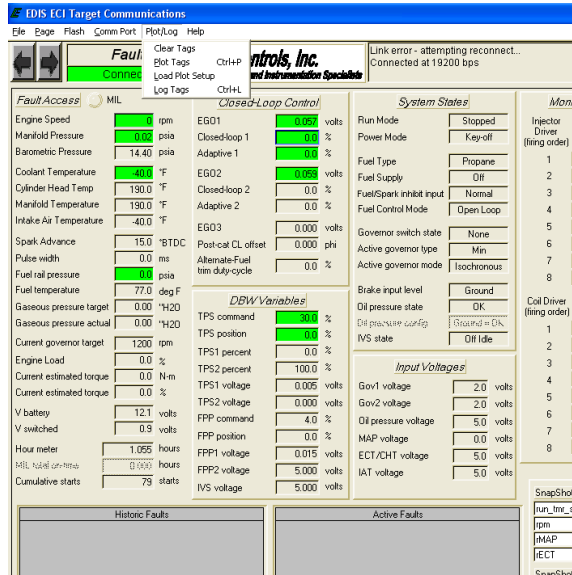

Figure 5: Tagged Variables for Plot/Log

Once the variables have been tagged as highlighted by the green color fill, select the "Plot/Log" function in the top menu bar as shown below in figure 6.

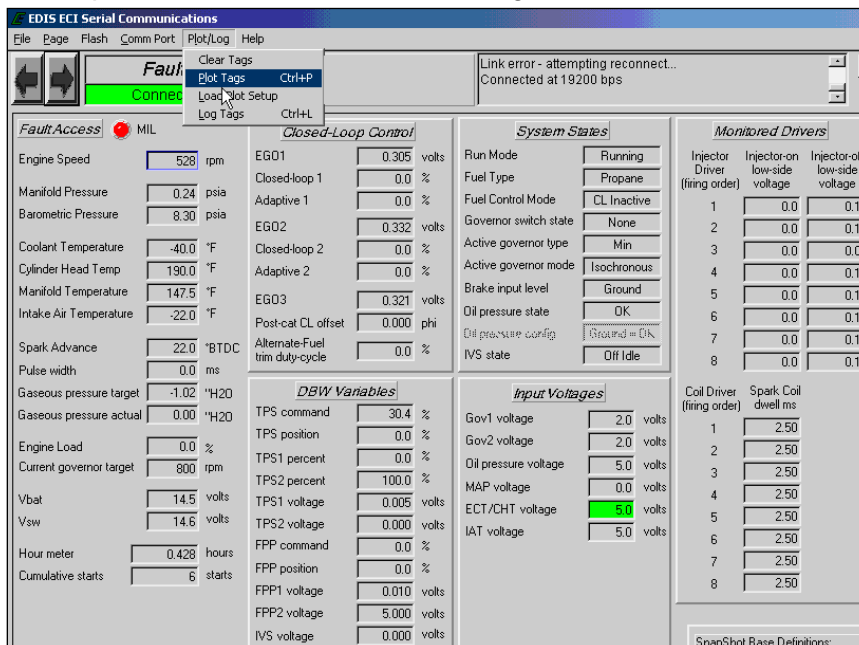

Figure 6

- Select “Plot Tags” to open the snapshot window

Other functions available from the Plot/Log menu include:

- **Clear Tags:** Releases all plot/log variables.
- **Plot Tags (Ctrl + P, or P):** Graphically plot all tagged variables.
- **Load Plot Setup:** Loads and tags variables for plotting/logging that have been stored in a plot file (.plt).
- **Log Tags (Ctrl + L):** Numerically log all variables that have been tagged for plotting/logging.

Once the Plot Tags menu item has been selected, tagged variables are graphically plotted in a strip chart interface. An example of a plot is shown in Figure 7. Capabilities of the plotter are outlined in Table 1.

| Start/Stop Button | Start or stop plotting of selected variables |
|---|---|
| Save Button | Save plotted data displayed in the plot to a comma-separated value file (CSV) on the PC hard drive. Format must not be altered if the <i>Load</i> function is to be used. |
| Snapshot Button | Convert the plot into a snapshot that may be panned, zoomed, scrolled, and saved |
| Close Button | Close the DST Plot interface |
| Load Setup Button | Load tags from a previously saved plot (.plt) file to allow for similar plots and logs to be generated |
| Load Plot Button | Load a previously saved plot from the PC into the DST Plot interface |
| Variable Selector Menu | Selects the active variable for axis scaling |
| Single Shot Acquisition Checkbox * | When checked, this does not allow the plot to scroll past the ‘Time Interval’ thereby preserving plotted data for post-processing. |
| Exclusive Serial Use Checkbox * | When checked, this allows exclusive serial communication for the plot variables. Other variables on the active page are not updated. |
| Min Y Value Field * | Specify the minimum Y-axis scaling for the active variable |
| Max Y Value Field * | Specify the maximum Y-axis scaling for the active variable |
| Sample Interval (ms) Field * | Define the sample period for recording and display <i>Frequency (Hz.) = 1000/Sample Interval (ms)</i> |
| Time Interval (s) Field * | Defines the total sample acquisition time for the plot. |
| *Accessible only when plotter is not running. | |

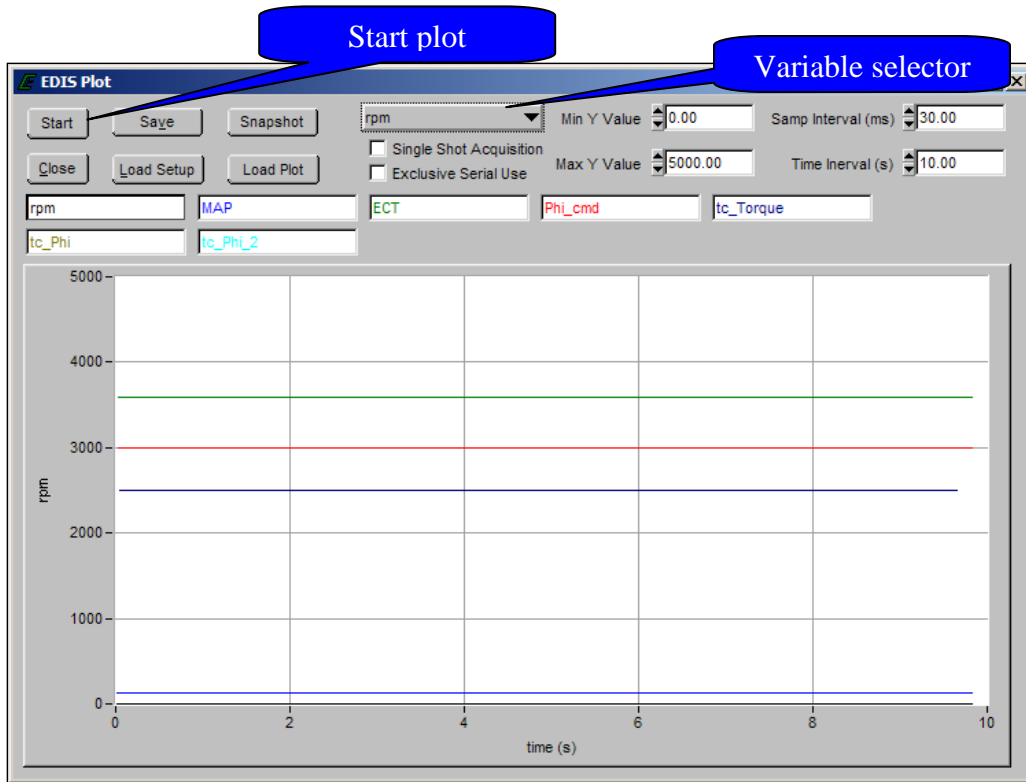

Figure 7: DST Plot

- Click on the “Start” button to start the DST plot function.
- Click on the variable selector button to view selected sensors

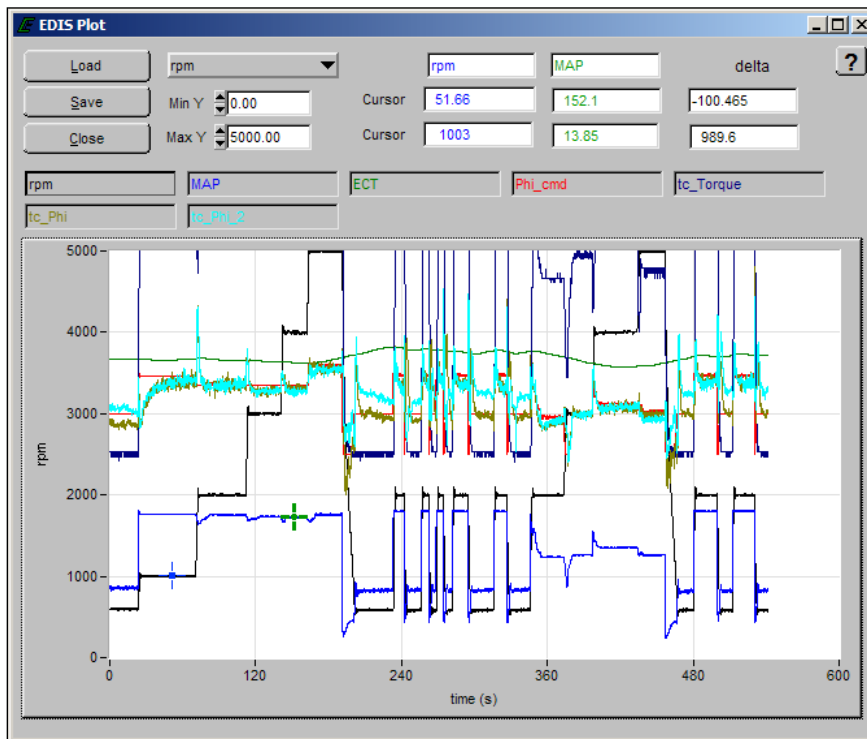
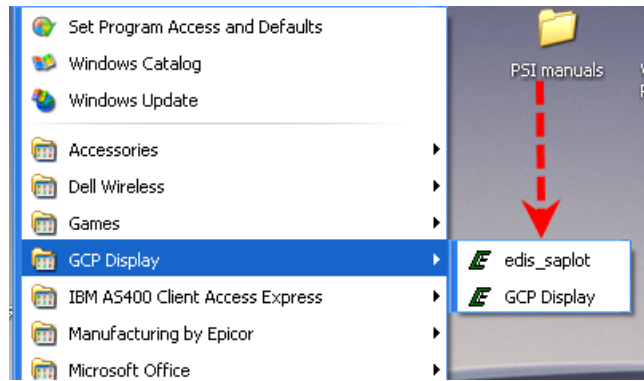

Figure 8: DST Plot Snapshot

- Click on the “Save” button to save the snapshot as a file. To replay the saved file, open the edis_saplot program from the windows start menu.



- Start Menu → Programs → NGE GCP Display → edis_saplot

DST PLOT INTERFACE FUNCTIONS

A graphic tool incorporated in the plotter is the snapshot function. This function allows data collected in a plot to be transferred into a second window for quick graphical post-processing. The snapshot allows the user to zoom in/out, pan left/right, and move cursors along the signal traces to measure the variable values in virtual real-time. An example of a snapshot is shown in Figure 8. Any CSV file in plot format (.plt) may be loaded into the snapshot. Table 2 outlines the available hot key functions of the snapshot screen.

SNAPSHOT HOT KEY FUNCTIONS

| Command | Function |
|----------------------------------|---|
| <Single, left-click on trace> | Snap closest cursor to data |
| <Ctrl + Up/Down Arrows> | Move/pan plot along y axis |
| <Ctrl + Left/Right Arrows> | Move/pan plot along t axis |
| <Ctrl+Shift + Up/Down Arrows> | Zoom plot in and out in y axis |
| <Ctrl+Shift + Left/Right Arrows> | Zoom plot in and out in t axis |
| <Ctrl + Home> | Resize plot to default settings |
| <Ctrl + Page Up> | Zoom out by 10% |
| <Ctrl + Page Down> | Zoom in by 10% |
| <Page Up> | Toggle to previous cursor |
| <Page Down> | Toggle to next cursor |
| <Left/Right Arrow> | Follow selected data along trace |
| <Up/Down Arrow> | Follow selected data along trace |
| <Shift + Left/Right Arrow> | Move 10 points along trace |
| <Shift + Up/Down Arrow> | Move 10 points along trace |
| <Home> | Go to first visible point on current plot |
| <End> | Advance to last visible point on current plot |
| <Shift + Up/Down Arrow> | Toggle between traces/variables |

Table 1

DST LOGGER

Another data capture function incorporated in the software is the DST logger. This tool serves as a PC data logger for any variable available in the ECM through the interface software. Figure 9 shows the interface display for configuring the DST Log. The interface allows the user to create the filename, set the sample rate for acquisition, set the time interval for sampling, and display the progress of acquisition. A maximum of twenty (20) variables may be tagged for the log. The amount of data stored is only limited by available PC RAM. The resulting text file may then be viewed by any standard Windows text editor/reader program. To create a log file select the “Log Tags” in the drop down menu as shown in figure 6.

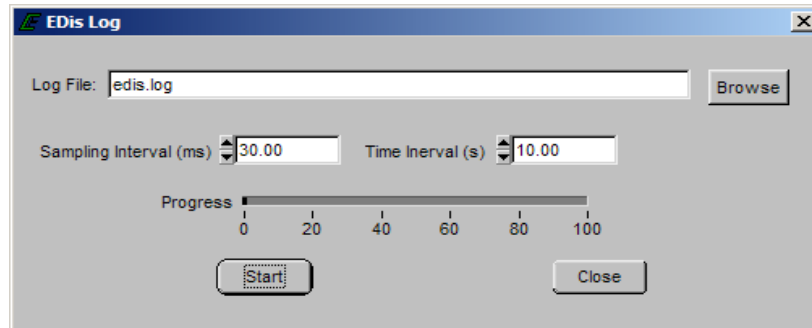

Figure 9: DST Log Interface

MALFUNCTION INDICATOR LAMP (MIL)

The Fuel system has built-in diagnostics for system trouble shooting. The system has a dash mounted malfunction indicator lamp (MIL) that provides indications of engine or fuel system related problem. Most engine control system related problems that affect emissions or drivability of the vehicle will set a (DTC) diagnostic trouble code and illuminate the MIL.

The MIL serves as notification to the operator of a problem related to the emission control system so the driver can arrange for service as soon as possible. It will also display DTCs that have been stored due to a system malfunction.

The MIL should illuminate when the key is in the ON position and the engine is not running. This feature verifies that the lamp is in proper working order. If the MIL does not illuminate with the vehicle key ON/engine OFF, repair it as soon as possible. Once the engine is in start or run mode, the MIL should turn off. If the lamp remains on while the engine is in the start or run mode a diagnostic trouble code may be set.

The MIL will be turned OFF after three (3) consecutive run cycles or by clearing the active code with the Diagnostic Scan Tool (DST).

DIAGNOSTIC TROUBLE CODES (DTC)

Diagnostic Trouble Codes are set when the Spectrum ECM (Electronic Control Module) runs a diagnostic self test and the test fails. When a DTC is set, the ECM will illuminate the MIL on the instrument panel and also save the DTC in memory. The ECM will continue to run the self test. If the system continues to fail the test, the lamp will stay illuminated and the DTC is stored as an active DTC. If the self test runs and passes, the DTC will be stored as historic DTC. All DTCs are stored as historic faults until they are cleared. Most DTCs will automatically clear from memory if

the DTC does not reset within 50 to 100 consecutive engine run cycles.

While a Diagnostic Trouble Code is current for a sensor, the ECM may assign a default “limp home” value and use that value in its control algorithms. All of the system diagnostic self-tests run continuously during normal vehicle operation.

The Diagnostic Trouble Codes can be read by using either the MIL lamp or a laptop computer. Diagnostic Trouble Codes can be cleared from memory with a laptop computer, or by turning the ignition key to the OFF position and removing the ECM power fuse or battery cable for at least 15 seconds.

If more than one DTC is detected, start the diagnostic repair with the lowest DTC number set. Diagnose each problem to correction unless directed to do otherwise by the diagnostic chart. The DTCs are numbered in order of importance. Both DTC 112 and DTC122 pertain to the oxygen sensor, so it is possible that a repair that corrects DTC 112 may also correct the problem causing the DTC 122.

Diagnostic test charts contained in this manual refer to the DST to be connected and in the “System Data Mode.” This simply means that the DST is connected and communicating with the PC. In some instances the chart will call out a special test mode. An example of this would be instructions for the DST to be connected and in the DBW (drive by wire) mode. Always be sure to follow the special instructions to avoid a false diagnosis of fuel system components.

DLC COMMUNICATION ERROR

The ECM 5 volt reference circuit powers the Spectrum diagnostic link cable. In the event that the 5 volt reference signal is open or shorted to ground, you will not be able to connect to the system. If you are unable to connect, follow the quick checks listed below:

Be sure you are using the correct password and latest software for the system you are connecting to.

Check the ECM system power and ground circuits. Refer to DTC 562 for the power schematic. Also check for +12 volts switched power at ECM pin 45 with the ignition key ON.

Check for power at the DLC connector for + 5 volts between pin 1 (BLK /LT GRN) and pin 2 (LT GRN RED) with the ignition key in the ON position.

You may still be able to retrieve a code using the blink code function if none of the above recommendations prove useful. In the event of a 5 volt reference signal malfunction, DTC 642 or DTC 643 should set. If you find one of these codes using the blink code function, follow the DTC diagnostic chart recommendations for that specific DTC.

BLINK CODE FUNCTION

Flashing Diagnostic Trouble Codes (DTC) using the blink code function is not available. DTC's will need to be pulled out of the ECM using the GCP Display software available from the OEM or PSI.

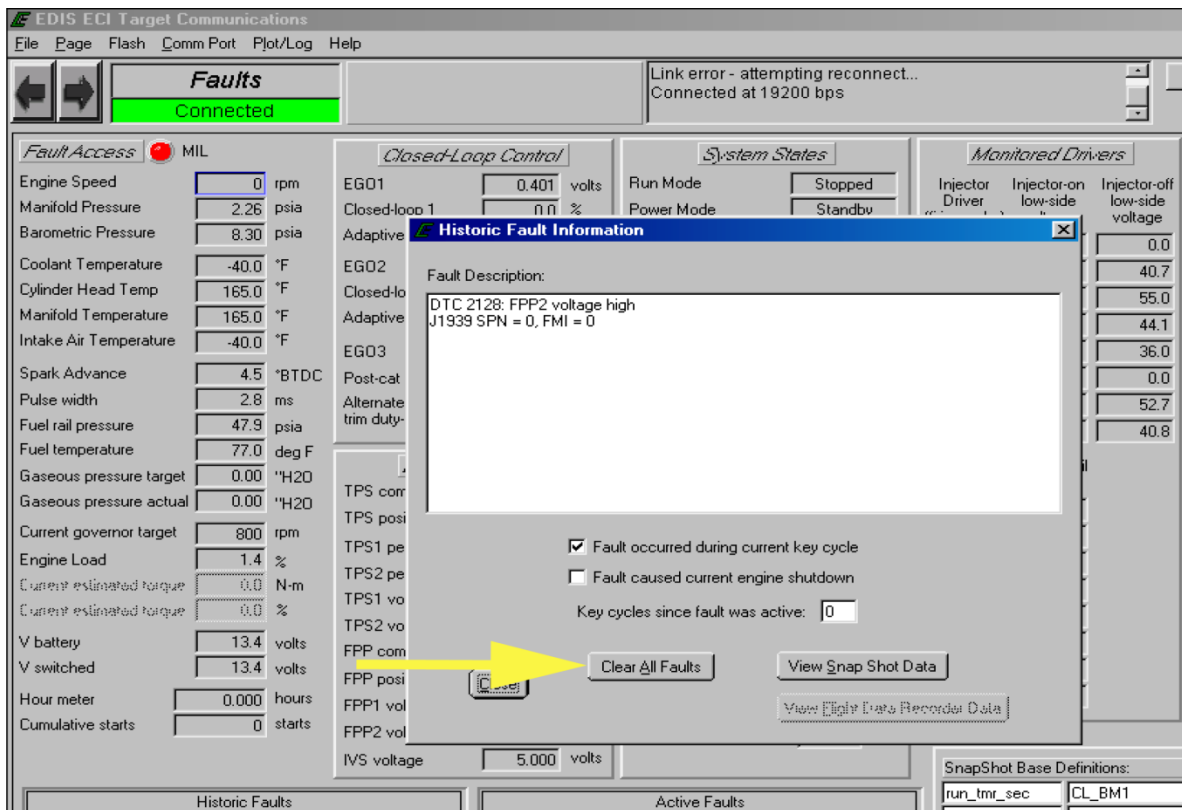

Diagram 1

When using the DST program to clear a DTC, always select the “Clear All Faults” function to immediately turn the MIL OFF after a successful repair (as shown in diagram 1 above).

INTERMITTENT PROBLEMS

Intermittent fuel system problems can prove to be the most challenging to repair. It is most important to remember when looking to find the cause of these problems, to operate the system in the condition when and where the problem occurs. An example of this would be, if the DST showed a lean fuel mixture at full load, one of the first things to look at would be the fuel pressure. The fuel pressure would need to be monitored while the machine is operating at full load, not at idle because the leaning effect does not occur at idle. Electrical problems should be treated the same way. One excellent tool for finding intermittent electrical problems is the DST plot/log function. Set up the plot for the code that sets. An example of this would be if an intermittent IAT code set, tag the IAT voltage and watch the plot. While watching the plot, agitate the electrical wire connection at the sensor and ECM connector. The resolution of the plot screen is such that you will be able to see any unstable voltages that you would otherwise not see with a standard DVOM.

Caution should be used when pressure washing the under hood of any electrical system. Avoid direct pressure spray on the system electrical connectors. They are splash proof, but if water is sprayed directly at the connector moisture can become trapped behind the connector seal and cause serious system problems.

Extra care must be taken when probing electrical pins and terminals. Do not bend or spread these terminals as this can also be a source of intermittent problems caused by improper handling of these connectors.

Engine Wire Harness Repair

ON-VEHICLE SERVICE WIRE HARNESS REPAIR

The ECM harness electrically connects the ECM to a various components in both the engine and passenger compartments.

Wire harnesses should be replaced with proper part number harnesses. When wires are spliced into a harness, use wire with high temperature insulation only.

Low current and voltage levels are used in the system, so it is important that the best possible bond at all wire splices be made by soldering the splices.

CONNECTORS AND TERMINALS

Use care when probing a connector or replacing terminals in them to prevent shorting opposite terminals and damage certain components. Always use jumper wires between connectors, for circuit checking. Do not probe through the Weather-Pack seals with oversized wire probes. Use tachometer adapter J 35812 (or equivalent) which provides an easy hook up of the tach lead. The connector test adapter kit J 35616 (or equivalent), contains an assortment of flexible connectors used to probe terminals during diagnosis. Fuse remover and test tool BT 8616, or equivalent, is used for removing a fuse and to adapt fuse holder, with a meter, for diagnosis. Do not solder oxygen sensor wire terminals as these wire ends are used for the sensors oxygen reference.

Open circuits are often difficult to locate by sight due to dirt, oxidation, or terminal misalignment. Merely wiggling a connector on a sensor, or in the wiring harness, may correct the open circuit condition. This should always be considered, when an open circuit, or failed sensor is indicated. Intermittent problems may also be caused by oxidized or loose connections.

Before making a connector repair, be certain of the type of connector. Weather-Pack and Compact Three connectors look similar, but are serviced differently.

REPAIRING TWISTED/SHIELDED CABLE

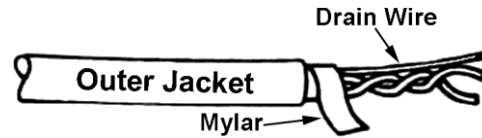

1. Remove outer jacket
2. Unwrap aluminum/Mylar tape. Do not remove Mylar.



3. Untwist conductors, strip insulation as necessary.

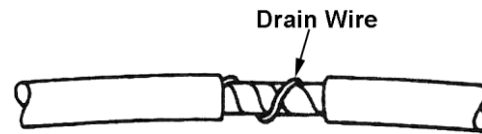

4. Splice wire using splice clips and rosin core solder. Wrap each splice to insulate.
5. Wrap with Mylar and drain wire (uninsulated) wire.



6. Tape over entire juncture and secure.

REPAIRING TWISTED LEADS



1. Locate Damaged Wire.
2. Remove insulation as required.

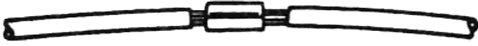

3. Splice two wires together using splice clips and rosin core solder.

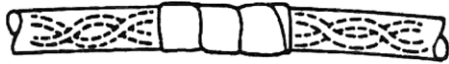

4. Cover splice with tape to insulated from other wires.
5. Retwist as before and tape with electrical tape and hold in place.

MICRO-PACK

Refer to Figure 2 and repair procedure for replacement of a Micro-Pack terminal.

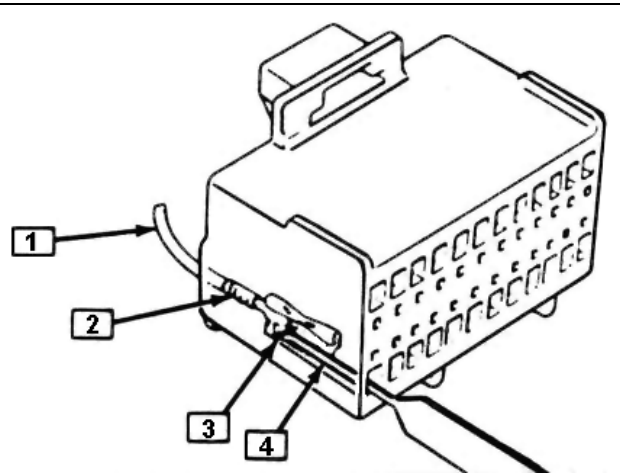

Micropack Connector

1. Cable
2. Terminal
3. Locking Tang
4. Tool J33095/BT8234-A

METRI-PACK

Some connectors use terminals called Metri-Pack Series 150. They are also called "Pull-To-Seat" terminals because of the method of installation. The wire is inserted through the seal and connector, the terminal is crimped on the wire and then pulled back into the connector to seat it in place.

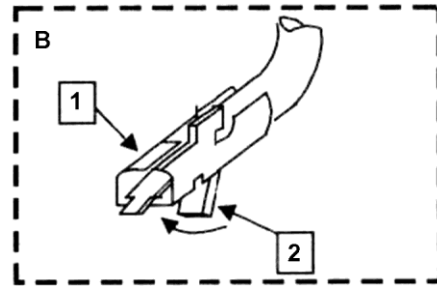
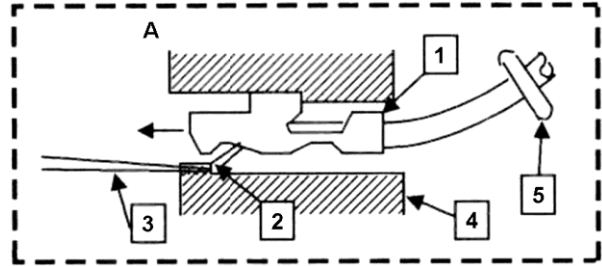

Metri-Pack Series 150 Terminal Removal

1. Slide the seal back on the wire.
2. Insert tool BT-8518, or J 35689, or equivalent, as shown in insert "A" and "B" to release the terminal locking tab (2).
3. Push the wire and terminal out through the connector. If reusing the terminal, reshape the locking tab (2).

WEATHER-PACK

A Weather-Pack connector can be identified by a rubber seal, at the rear of the connector. The connector is used in the engine compartment to protect against moisture and dirt that may oxidize and/or corrode the terminals. Given the low voltage and current levels found in the electronic system, this protection is necessary to ensure a good connection.

WEATHER-PACK TERMINAL REPAIR

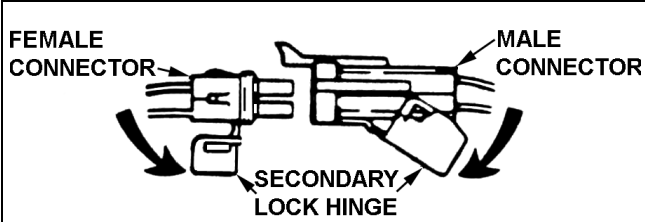

1. Open secondary lock hinge on connector.

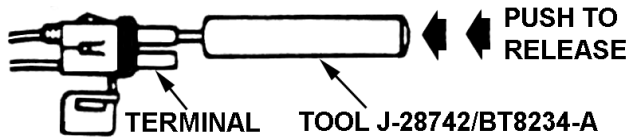

2. Remove terminal using tool.

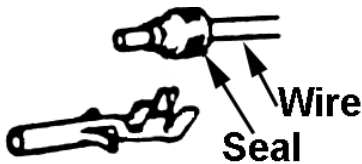

3. Cut wire immediately behind cable seal

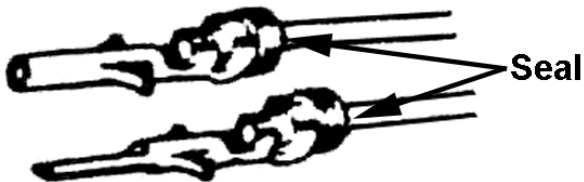

4. Replace terminal.
 - a. Slip new seal onto wire
 - b. Strip 5 mm (.2") of insulation from wire.
 - c. Crimp terminal over wire and seal.
5. Push terminal and connector and engage locking tangs.
6. Close secondary lock hinge.

Use tool J M28742, or BT8234-A or equivalent to remove the pin and sleeve terminals. If the removal is attempted with an ordinary pick, there is a good chance that the terminal will be bent, or deformed. Unlike standard blade type terminals, these terminals cannot be straightened once they are bent.

Verify that the connectors are properly seated and all of the sealing rings in place, when connecting leads. The hinge type flap provides a backup, or secondary locking feature for the connector. They are used to improve the connector reliability by retaining the terminals, if the small terminal lock tabs are not positioned properly.

Weather-Pack connections cannot be replaced with standard connections. Additional instructions are provided with Weather-Pack connector and terminal packages.

Diagnostic Trouble Codes (DTCs)

DIAGNOSTIC TROUBLE CODE (DTC) CHART – **SORTED BY DTC # (1 of 4)**

| Description | DTC Set 2 | | Description | DTC Set 2 | |
|---|-----------|-------|---|-----------|-------|
| | SPN-2 | FMI-2 | | SPN-2 | FMI-2 |
| DTC 11: Intake cam / distributor position error | 520800 | 7 | DTC 268: Injector 3 coil shorted | 653 | 6 |
| DTC 16: Crank and/or cam could not synchronize during start | 636 | 8 | DTC 270: Injector 4 open or short to ground | 654 | 5 |
| DTC 24: Exhaust cam position error | 520801 | 7 | DTC 271: Injector 4 coil shorted | 654 | 6 |
| DTC 87 Fuel pressure lower than expected | 94 | 1 | DTC 273: Injector 5 open or short to ground | 655 | 5 |
| DTC 88 Fuel pressure higher than expected | 94 | 0 | DTC 274: Injector 5 coil shorted | 655 | 6 |
| DTC 91: FP low voltage | 94 | 4 | DTC 276: Injector 6 open or short to ground | 656 | 5 |
| DTC 92: FP high voltage | 94 | 3 | DTC 277: Injector 6 coil shorted | 656 | 6 |
| DTC 107: MAP voltage low | 106 | 4 | DTC 279: Injector 7 open or short to ground | 657 | 5 |
| DTC 108: MAP pressure high | 106 | 16 | DTC 280: Injector 7 coil shorted | 657 | 6 |
| DTC 111: IAT higher than expected stage 1 | 105 | 15 | DTC 282: Injector 8 open or short to ground | 658 | 5 |
| DTC 112: IAT voltage low | 105 | 4 | DTC 283: Injector 8 coil shorted | 658 | 6 |
| DTC 113: IAT voltage high | 105 | 3 | DTC 285: Injector 9 open or short to ground | 659 | 5 |
| DTC 116: ECT higher than expected stage 1 | 110 | 15 | DTC 286: Injector 9 coil shorted | 659 | 6 |
| DTC 117: ECT voltage low | 110 | 4 | DTC 288: Injector 10 open or short to ground | 660 | 5 |
| DTC 118: ECT voltage high | 110 | 3 | DTC 289: Injector 10 coil shorted | 660 | 6 |
| DTC 121: TPS1-2 lower than expected | 51 | 1 | DTC 1631: PWM1-Gauge1 open / ground short | 697 | 5 |
| DTC 122: TPS1 voltage low | 51 | 4 | DTC 299: Boost control underboost failure | 1692 | 1 |
| DTC 123: TPS1 voltage high | 51 | 3 | DTC 301: Cylinder 1 emissions/catalyst damaging misfire | 1323 | 31 |
| DTC 127: IAT higher than expected stage 2 | 105 | 0 | DTC 302: Cylinder 2 emissions/catalyst damaging misfire | 1324 | 31 |
| DTC 129: BP pressure low | 108 | 1 | DTC 303: Cylinder 3 emissions/catalyst damaging misfire | 1325 | 31 |
| DTC 134: EGO1 open / lazy | 724 | 10 | DTC 304: Cylinder 4 emissions/catalyst damaging misfire | 1326 | 31 |
| DTC 140: EGO3 open / lazy | 520209 | 10 | DTC 305: Cylinder 5 emissions/catalyst damaging misfire | 1327 | 31 |
| DTC 154: EGO2 open / lazy | 520208 | 10 | DTC 306: Cylinder 6 emissions/catalyst damaging misfire | 1328 | 31 |
| DTC 160: EGO4 open / lazy | 520210 | 10 | DTC 307: Cylinder 7 emissions/catalyst damaging misfire | 1329 | 31 |
| DTC 171: Adaptive-learn gasoline bank1 high | 520200 | 0 | DTC 308: Cylinder 8 emissions/catalyst damaging misfire | 1330 | 31 |
| DTC 172: Adaptive-learn gasoline bank1 low | 520200 | 1 | DTC 326: Knock1 excessive or erratic signal | 731 | 2 |
| DTC 174: Adaptive-learn gasoline bank2 high | 520201 | 0 | DTC 327: Knock1 sensor open or not present | 731 | 4 |
| DTC 175: Adaptive-learn gasoline bank2 low | 520201 | 1 | DTC 331: Knock2 excessive or erratic signal | 520241 | 2 |
| DTC 182: FT low voltage | 174 | 4 | DTC 332: Knock2 sensor open or not present | 520241 | 4 |
| DTC 183: FT high voltage | 174 | 3 | DTC 336: CRANK input signal noise | 636 | 2 |
| DTC 187: Gaseous fuel temperature sender low voltage | 520240 | 4 | DTC 337: Crank signal loss | 636 | 4 |
| DTC 188: Gaseous fuel temperature sender high voltage | 520240 | 3 | DTC 341: CAM input signal noise | 723 | 2 |
| DTC 217: ECT higher than expected stage 2 | 110 | 0 | DTC 342: Loss of CAM input signal | 723 | 4 |
| DTC 219: RPM higher than max allowed govern speed | 515 | 15 | DTC 359: Fuel run-out longer than expected | 1239 | 7 |
| DTC 221: TPS1-2 higher than expected | 51 | 0 | DTC 420: Catalyst inactive on gasoline (Bank 1) | 520211 | 10 |
| DTC 222: TPS2 voltage low | 520251 | 4 | DTC 430: Catalyst inactive on gasoline (Bank 2) | 520212 | 10 |
| DTC 223: TPS2 voltage high | 520251 | 3 | DTC 502: Roadspeed input loss of signal | 84 | 1 |
| DTC 234: Boost control overboost failure | 1692 | 0 | DTC 508: IAC ground short | 520252 | 6 |
| DTC 236: TIP active | 1692 | 2 | DTC 509: IAC coil open/short | 520252 | 5 |
| DTC 237: TIP low voltage | 1127 | 4 | DTC 520: Oil pressure sender low pressure stage 1 | 100 | 18 |
| DTC 238: TIP high voltage | 1127 | 3 | DTC 521: Oil pressure sender high pressure | 100 | 0 |
| DTC 261: Injector 1 open or short to ground | 651 | 5 | DTC 522: Oil pressure sender low voltage | 100 | 4 |
| DTC 262: Injector 1 coil shorted | 651 | 6 | DTC 523: Oil pressure sender high voltage | 100 | 3 |
| DTC 264: Injector 2 open or short to ground | 652 | 5 | DTC 524: Oil pressure low | 100 | 1 |
| DTC 265: Injector 2 coil shorted | 652 | 6 | DTC 562: Vbat voltage low | 168 | 17 |
| DTC 267: Injector 3 open or short to ground | 653 | 5 | DTC 563: Vbat voltage high | 168 | 15 |

DIAGNOSTIC TROUBLE CODE (DTC) CHART – SORTED BY DTC # (2 of 4)

| Description | DTC Set 2 | | Description | DTC Set 2 | |
|--|-----------|-------|---|-----------|-------|
| | SPN-2 | FMI-2 | | SPN-2 | FMI-2 |
| DTC 601: Microprocessor failure - FLASH | 628 | 13 | DTC 1175: MegaJector voltage supply low | 520260 | 4 |
| DTC 604: Microprocessor failure - RAM | 630 | 12 | DTC 1176: MegaJector internal actuator fault detection | 520260 | 12 |
| DTC 606: Microprocessor failure - COP | 629 | 31 | DTC 1177: MegaJector internal circuitry fault detection | 520260 | 12 |
| DTC 615: Start relay coil open | 1321 | 5 | DTC 1178: MegaJector internal comm fault detection | 520260 | 12 |
| DTC 616: Start relay ground short | 1321 | 4 | DTC 1182: Fuel impurity level high | 520401 | 0 |
| DTC 617: Start relay coil short to power | 1321 | 3 | DTC 1183: MegaJector autozero / lockoff failure | 520803 | 31 |
| DTC 627: Fuel pump relay coil open | 1348 | 5 | DTC 1311: Cylinder 1 misfire detected | 1323 | 11 |
| DTC 628: Fuel-pump high-side open or short to ground | 1347 | 5 | DTC 1312: Cylinder 2 misfire detected | 1324 | 11 |
| DTC 628: Fuel pump relay control ground short | 1348 | 4 | DTC 1313: Cylinder 3 misfire detected | 1325 | 11 |
| DTC 629: Fuel-pump high-side short to power | 1347 | 6 | DTC 1314: Cylinder 4 misfire detected | 1326 | 11 |
| DTC 629: Fuel pump relay coil short to power | 1348 | 3 | DTC 1315: Cylinder 5 misfire detected | 1327 | 11 |
| DTC 642: Sensor supply voltage 1 low | 1079 | 4 | DTC 1316: Cylinder 6 misfire detected | 1328 | 11 |
| DTC 643: Sensor supply voltage 1 high | 1079 | 3 | DTC 1317: Cylinder 7 misfire detected | 1329 | 11 |
| DTC 650: MIL open | 1213 | 5 | DTC 1318: Cylinder 8 misfire detected | 1330 | 11 |
| DTC 652: Sensor supply voltage 2 low | 1080 | 4 | DTC 1411: EMWT1 voltage high | 441 | 3 |
| DTC 653: Sensor supply voltage 2 high | 1080 | 3 | DTC 1412: EMWT2 voltage high | 442 | 3 |
| DTC 685: Power relay coil open | 1485 | 5 | DTC 1413: EMWT1 voltage low | 441 | 4 |
| DTC 686: Power relay ground short | 1485 | 4 | DTC 1414: EMWT2 voltage low | 442 | 4 |
| DTC 687: Power relay coil short to power | 1485 | 3 | DTC 1415: EMWT1 higher than expected stage 1 | 441 | 15 |
| DTC 916: Shift actuator feedback out-of-range | 520226 | 3 | DTC 1416: EMWT2 higher than expected stage 1 | 442 | 15 |
| DTC 919: Shift unable to reach desired gear | 520226 | 7 | DTC 1417: EMWT1 higher than expected stage 2 | 441 | 0 |
| DTC 920: Shift actuator or drive circuit failed | 520226 | 31 | DTC 1418: EMWT2 higher than expected stage 2 | 442 | 0 |
| DTC 1111: RPM above fuel rev limit level | 515 | 16 | DTC 1419: ERWT1 voltage high | 443 | 3 |
| DTC 1112: RPM above spark rev limit level | 515 | 0 | DTC 1420: ERWT2 voltage high | 444 | 3 |
| DTC 1121: FPP1/2 simultaneous voltages out-of-range (redundan | 91 | 31 | DTC 1421: ERWT1 voltage low | 443 | 4 |
| DTC 1122: FPP1/2 do not match each other or IVS (redundancy cl | 520250 | 31 | DTC 1422: ERWT2 voltage low | 444 | 4 |
| DTC 1131: WGP voltage high | 1192 | 3 | DTC 1423: ERWT1 higher than expected stage 1 | 443 | 15 |
| DTC 1132: WGP voltage low | 1192 | 4 | DTC 1424: ERWT2 higher than expected stage 1 | 444 | 15 |
| DTC 1151: Closed-loop LPG high | 520206 | 0 | DTC 1425: ERWT1 higher than expected stage 2 | 443 | 0 |
| DTC 1152: Closed-loop LPG low | 520206 | 1 | DTC 1426: ERWT2 higher than expected stage 2 | 444 | 0 |
| DTC 1153: Closed-loop NG high | 520207 | 0 | DTC 1511: AUX analog Pull-Up 1 high voltage | 520216 | 3 |
| DTC 1154: Closed-loop NG low | 520207 | 1 | DTC 1512: AUX analog Pull-Up 1 low voltage | 520216 | 4 |
| DTC 1155: Closed-loop gasoline bank1 high | 520204 | 0 | DTC 1513: AUX analog Pull-Up 2 high voltage | 520217 | 3 |
| DTC 1156: Closed-loop gasoline bank1 low | 520204 | 1 | DTC 1514: AUX analog Pull-Up 2 low voltage | 520217 | 4 |
| DTC 1157: Closed-loop gasoline bank2 high | 520205 | 0 | DTC 1515: AUX analog Pull-Down 1 high voltage | 520215 | 3 |
| DTC 1158: Closed-loop gasoline bank2 low | 520205 | 1 | DTC 1516: AUX analog Pull-Down 1 low voltage | 520215 | 4 |
| DTC 1161: Adaptive-learn LPG high | 520202 | 0 | DTC 1517: AUX analog Pull-Up 3 high voltage | 520218 | 3 |
| DTC 1162: Adaptive-learn LPG low | 520202 | 1 | DTC 1518: AUX analog Pull-Up 3 low voltage | 520218 | 4 |
| DTC 1163: Adaptive-learn NG high | 520203 | 0 | DTC 1521: CHT higher than expected stage 1 | 110 | 16 |
| DTC 1164: Adaptive-learn NG low | 520203 | 1 | DTC 1522: CHT higher than expected stage 2 | 110 | 0 |
| DTC 1165: Catalyst inactive on LPG | 520213 | 10 | DTC 1531: Gov1/2/3 interlock failure | 520270 | 31 |
| DTC 1166: Catalyst inactive on NG | 520214 | 10 | DTC 1541: AUX analog Pull-Up/Down 1 high voltage | 520219 | 3 |
| DTC 1171: MegaJector delivery pressure higher than expected | 520260 | 0 | DTC 1542: AUX analog Pull-Up/Down 1 low voltage | 520219 | 4 |
| DTC 1172: MegaJector delivery pressure lower than expected | 520260 | 1 | DTC 1543: AUX analog Pull-Up/Down 2 high voltage | 520220 | 3 |
| DTC 1173: MegaJector comm lost | 520260 | 31 | DTC 1544: AUX analog Pull-Up/Down 2 low voltage | 520220 | 4 |
| DTC 1174: MegaJector voltage supply high | 520260 | 3 | DTC 1545: AUX analog Pull-Up/Down 3 high voltage | 520221 | 3 |

DIAGNOSTIC TROUBLE CODE (DTC) CHART – **SORTED BY DTC # (3 of 4)**

| Description | DTC Set 2 | | Description | DTC Set 2 | |
|--|-----------|-------|--|-----------|-------|
| | SPN-2 | FMI-2 | | SPN-2 | FMI-2 |
| DTC 1546: AUX analog Pull-Up/Down 3 low voltage | 520221 | 4 | DTC 1662: PWM6 short to power | 925 | 3 |
| DTC 1547: AUX analog Pull-Up/Down 4 high voltage | 713 | 3 | DTC 1663: PWM7 open / ground short | 926 | 5 |
| DTC 1548: AUX analog Pull-Up/Down 4 low voltage | 713 | 4 | DTC 1664: PWM7 short to power | 926 | 3 |
| DTC 1551: AUX digital 1 high voltage | 520222 | 3 | DTC 1665: PWM8 open / ground short | 2646 | 5 |
| DTC 1552: AUX digital 1 low voltage | 520222 | 4 | DTC 1666: PWM8 short to power | 2646 | 3 |
| DTC 1553: AUX digital 2 high voltage | 520223 | 3 | DTC 1669: PWM9 open / ground short | 2647 | 5 |
| DTC 1554: AUX digital 2 low voltage | 520223 | 4 | DTC 1670: PWM9 short to power | 2647 | 3 |
| DTC 1555: AUX digital 3 high voltage | 520224 | 3 | DTC 2111: Unable to reach lower TPS | 51 | 7 |
| DTC 1555: Water Intrusion Detection | 520224 | 3 | DTC 2112: Unable to reach higher TPS | 51 | 7 |
| DTC 1556: AUX digital 3 low voltage | 520224 | 4 | DTC 2115: FPP1 higher than IVS | 91 | 0 |
| DTC 1561: AUX analog Pull-Down 2 high voltage | 0 | 3 | DTC 2116: FPP2 higher than IVS | 29 | 0 |
| DTC 1561: AUX analog Pull-Down 3 high voltage | 0 | 3 | DTC 2120: FPP1 invalid voltage and FPP2 disagrees with IVS | 520250 | 31 |
| DTC 1561: AUX analog Pull-Down 2 low voltage | 0 | 4 | DTC 2121: FPP1-2 lower than expected | 91 | 18 |
| DTC 1561: AUX analog Pull-Down 3 low voltage | 0 | 4 | DTC 2122: FPP1 voltage high | 91 | 3 |
| DTC 1611: Sensor supply voltage 1 and 2 out-of-range | 1079 | 31 | DTC 2123: FPP1 voltage low | 91 | 4 |
| DTC 1612: Microprocessor failure - RTI 1 | 629 | 31 | DTC 2125: FPP2 invalid voltage and FPP2 disagrees with IVS | 520250 | 31 |
| DTC 1613: Microprocessor failure - RTI 2 | 629 | 31 | DTC 2126: FPP1-2 higher than expected | 91 | 16 |
| DTC 1614: Microprocessor failure - RTI 3 | 629 | 31 | DTC 2127: FPP2 voltage low | 29 | 4 |
| DTC 1615: Microprocessor failure - A/D | 629 | 31 | DTC 2128: FPP2 voltage high | 29 | 3 |
| DTC 1616: Microprocessor failure - Interrupt | 629 | 31 | DTC 2130: IVS stuck at-idle, FPP1/2 match | 558 | 5 |
| DTC 1621: RS-485 Rx inactive | 0 | 31 | DTC 2131: IVS stuck off-idle, FPP1/2 match | 558 | 6 |
| DTC 1622: RS-485 Rx noise | 0 | 31 | DTC 2135: TPS1/2 simultaneous voltages out-of-range | 51 | 31 |
| DTC 1623: RS-485 Rx bad packet format | 0 | 31 | DTC 2139: FPP1 lower than IVS | 91 | 1 |
| DTC 1624: RS-485 remote shutdown request | 0 | 31 | DTC 2140: FPP2 lower than IVS | 29 | 1 |
| DTC 1625: J1939 shutdown request | 1384 | 31 | DTC 2229: BP pressure high | 108 | 0 |
| DTC 1626: CAN-J1939 Tx fault | 639 | 12 | DTC 2300: Spark coil 1 primary open or short to ground | 1268 | 5 |
| DTC 1627: CAN-J1939 Rx fault | 639 | 12 | DTC 2301: Spark coil 1 primary shorted | 1268 | 6 |
| DTC 1628: J1939 CAN address / engine-number conflict | 639 | 13 | DTC 2303: Spark coil 2 primary open or short to ground | 1269 | 5 |
| DTC 1629: J1939 TSC1 message receipt loss | 639 | 9 | DTC 2304: Spark coil 2 primary shorted | 1269 | 6 |
| DTC 1630: J1939 ETC message receipt loss | 91 | 2 | DTC 2306: Spark coil 3 primary open or short to ground | 1270 | 5 |
| DTC 1632: PWM1-Gauge1 short to power | 697 | 6 | DTC 2307: Spark coil 3 primary shorted | 1270 | 6 |
| DTC 1633: PWM2-Gauge2 open / ground short | 698 | 5 | DTC 2309: Spark coil 4 primary open or short to ground | 1271 | 5 |
| DTC 1634: PWM2-Gauge2 short to power | 698 | 6 | DTC 2310: Spark coil 4 primary shorted | 1271 | 6 |
| DTC 1635: PWM3-Gauge3 open / ground short | 699 | 5 | DTC 2312: Spark coil 5 primary open or short to ground | 1272 | 5 |
| DTC 1636: PWM3-Gauge3 short to power | 699 | 6 | DTC 2313: Spark coil 5 primary shorted | 1272 | 6 |
| DTC 1637: PWM4 open / ground short | 700 | 5 | DTC 2315: Spark coil 6 primary open or short to ground | 1273 | 5 |
| DTC 1638: PWM4 short to power | 700 | 6 | DTC 2316: Spark coil 6 primary shorted | 1273 | 6 |
| DTC 1639: PWM5 open / ground short | 520230 | 5 | DTC 2318: Spark coil 7 primary open or short to ground | 1274 | 5 |
| DTC 1640: PWM5 short to power | 520230 | 6 | DTC 2319: Spark coil 7 primary shorted | 1274 | 6 |
| DTC 1641: Buzzer control ground short | 920 | 4 | DTC 2321: Spark coil 8 primary open or short to ground | 1275 | 5 |
| DTC 1642: Buzzer open | 920 | 5 | DTC 2322: Spark coil 8 primary shorted | 1275 | 6 |
| DTC 1643: Buzzer control short to power | 920 | 3 | DTC 2324: Spark coil 9 primary open or short to ground | 1276 | 5 |
| DTC 1644: MIL control ground short | 1213 | 4 | DTC 2325: Spark coil 9 primary shorted | 1276 | 6 |
| DTC 1645: MIL control short to power | 1213 | 3 | DTC 2327: Spark coil 10 primary open or short to ground | 1277 | 5 |
| DTC 1651: J1939 ETC message receipt loss while in-gear | 91 | 9 | DTC 2328: Spark coil 10 primary shorted | 1277 | 6 |
| DTC 1661: PWM6 open / ground short | 925 | 5 | DTC 2428: EGT temperature high | 173 | 0 |

DIAGNOSTIC TROUBLE CODE (DTC) CHART – SORTED BY DTC # (4 of 4)

| Description | DTC Set 2 | |
|---|-----------|-------|
| | SPN-2 | FMI-2 |
| DTC 2618: Tach output ground short | 645 | 4 |
| DTC 2619: Tach output short to power | 645 | 3 |
| DTC 8901: UEGO microprocessor internal fault | 3221 | 31 |
| DTC 8902: UEGO heater supply high voltage | 3222 | 3 |
| DTC 8903: UEGO heater supply low voltage | 3222 | 4 |
| DTC 8904: UEGO cal resistor voltage high | 3221 | 3 |
| DTC 8905: UEGO cal resistor voltage low | 3221 | 4 |
| DTC 8906: UEGO return voltage shorted high | 3056 | 3 |
| DTC 8907: UEGO return voltage shorted low | 3056 | 4 |
| DTC 8908: UEGO pump voltage shorted high | 3218 | 3 |
| DTC 8909: UEGO pump voltage shorted low | 3218 | 4 |
| DTC 8910: UEGO sense cell voltage high | 3217 | 3 |
| DTC 8911: UEGO sense cell voltage low | 3217 | 4 |
| DTC 8912: UEGO pump voltage at high drive limit | 3225 | 3 |
| DTC 8913: UEGO pump voltage at low drive limit | 3225 | 4 |
| DTC 8914: UEGO sense cell slow to warm up | 3222 | 10 |
| DTC 8915: UEGO pump cell slow to warm up | 3225 | 10 |
| DTC 8916: UEGO sense cell impedance high | 3222 | 0 |
| DTC 8917: UEGO pump cell impedance high | 3225 | 0 |
| DTC 8918: UEGO pump cell impedance low | 3225 | 1 |

DIAGNOSTIC TROUBLE CODE (DTC) CHART – SORTED BY SPN:FMI (1 of 4)

| Description | DTC Set 2 | | Description | DTC Set 2 | |
|---|-----------|-------|---|-----------|-------|
| | SPN-2 | FMI-2 | | SPN-2 | FMI-2 |
| DTC 1561: AUX analog Pull-Down 2 high voltage | 0 | 3 | DTC 107: MAP voltage low | 106 | 4 |
| DTC 1561: AUX analog Pull-Down 3 high voltage | 0 | 3 | DTC 108: MAP pressure high | 106 | 16 |
| DTC 1561: AUX analog Pull-Down 2 low voltage | 0 | 4 | DTC 2229: BP pressure high | 108 | 0 |
| DTC 1561: AUX analog Pull-Down 3 low voltage | 0 | 4 | DTC 129: BP pressure low | 108 | 1 |
| DTC 1621: RS-485 Rx inactive | 0 | 31 | DTC 1522: CHT higher than expected stage 2 | 110 | 0 |
| DTC 1622: RS-485 Rx noise | 0 | 31 | DTC 217: ECT higher than expected stage 2 | 110 | 0 |
| DTC 1623: RS-485 Rx bad packet format | 0 | 31 | DTC 118: ECT voltage high | 110 | 3 |
| DTC 1624: RS-485 remote shutdown request | 0 | 31 | DTC 117: ECT voltage low | 110 | 4 |
| Undefined DTC - Index 10297 | 0 | 31 | DTC 116: ECT higher than expected stage 1 | 110 | 15 |
| Undefined DTC - Index 10298 | 0 | 31 | DTC 1521: CHT higher than expected stage 1 | 110 | 16 |
| Undefined DTC - Index 10299 | 0 | 31 | DTC 563: Vbat voltage high | 168 | 15 |
| DTC 2116: FPP2 higher than IVS | 29 | 0 | DTC 562: Vbat voltage low | 168 | 17 |
| DTC 2140: FPP2 lower than IVS | 29 | 1 | DTC 2428: EGT temperature high | 173 | 0 |
| DTC 2128: FPP2 voltage high | 29 | 3 | DTC 183: FT high voltage | 174 | 3 |
| DTC 2127: FPP2 voltage low | 29 | 4 | DTC 182: FT low voltage | 174 | 4 |
| DTC 221: TPS1-2 higher than expected | 51 | 0 | DTC 1417: EMWT1 higher than expected stage 2 | 441 | 0 |
| DTC 121: TPS1-2 lower than expected | 51 | 1 | DTC 1411: EMWT1 voltage high | 441 | 3 |
| DTC 123: TPS1 voltage high | 51 | 3 | DTC 1413: EMWT1 voltage low | 441 | 4 |
| DTC 122: TPS1 voltage low | 51 | 4 | DTC 1415: EMWT1 higher than expected stage 1 | 441 | 15 |
| DTC 2112: Unable to reach higher TPS | 51 | 7 | DTC 1418: EMWT2 higher than expected stage 2 | 442 | 0 |
| DTC 2111: Unable to reach lower TPS | 51 | 7 | DTC 1412: EMWT2 voltage high | 442 | 3 |
| DTC 2135: TPS1/2 simultaneous voltages out-of-ran | 51 | 31 | DTC 1414: EMWT2 voltage low | 442 | 4 |
| DTC 502: Roadspeed input loss of signal | 84 | 1 | DTC 1416: EMWT2 higher than expected stage 1 | 442 | 15 |
| DTC 2115: FPP1 higher than IVS | 91 | 0 | DTC 1425: ERWT1 higher than expected stage 2 | 443 | 0 |
| DTC 2139: FPP1 lower than IVS | 91 | 1 | DTC 1419: ERWT1 voltage high | 443 | 3 |
| DTC 1630: J1939 ETC message receipt loss | 91 | 2 | DTC 1421: ERWT1 voltage low | 443 | 4 |
| DTC 2122: FPP1 voltage high | 91 | 3 | DTC 1423: ERWT1 higher than expected stage 1 | 443 | 15 |
| DTC 2123: FPP1 voltage low | 91 | 4 | DTC 1426: ERWT2 higher than expected stage 2 | 444 | 0 |
| DTC 1651: J1939 ETC message receipt loss while in | 91 | 9 | DTC 1420: ERWT2 voltage high | 444 | 3 |
| DTC 2126: FPP1-2 higher than expected | 91 | 16 | DTC 1422: ERWT2 voltage low | 444 | 4 |
| DTC 2121: FPP1-2 lower than expected | 91 | 18 | DTC 1424: ERWT2 higher than expected stage 1 | 444 | 15 |
| DTC 1121: FPP1/2 simultaneous voltages out-of-ran | 91 | 31 | DTC 1112: RPM above spark rev limit level | 515 | 0 |
| DTC 88 Fuel pressure higher than expected | 94 | 0 | DTC 219: RPM higher than max allowed govern speed | 515 | 15 |
| DTC 87 Fuel pressure lower than expected | 94 | 1 | DTC 1111: RPM above fuel rev limit level | 515 | 16 |
| DTC 92: FP high voltage | 94 | 3 | DTC 2130: IVS stuck at-idle, FPP1/2 match | 558 | 5 |
| DTC 91: FP low voltage | 94 | 4 | DTC 2131: IVS stuck off-idle, FPP1/2 match | 558 | 6 |
| DTC 521: Oil pressure sender high pressure | 100 | 0 | DTC 601: Microprocessor failure - FLASH | 628 | 13 |
| DTC 524: Oil pressure low | 100 | 1 | DTC 606: Microprocessor failure - COP | 629 | 31 |
| DTC 524: Oil pressure sender low pressure | 100 | 1 | DTC 1612: Microprocessor failure - RTI 1 | 629 | 31 |
| DTC 523: Oil pressure sender high voltage | 100 | 3 | DTC 1613: Microprocessor failure - RTI 2 | 629 | 31 |
| DTC 522: Oil pressure sender low voltage | 100 | 4 | DTC 1614: Microprocessor failure - RTI 3 | 629 | 31 |
| DTC 520: Oil pressure sender low pressure stage 1 | 100 | 18 | DTC 1615: Microprocessor failure - A/D | 629 | 31 |
| DTC 127: IAT higher than expected stage 2 | 105 | 0 | DTC 1616: Microprocessor failure - Interrupt | 629 | 31 |
| DTC 113: IAT voltage high | 105 | 3 | DTC 604: Microprocessor failure - RAM | 630 | 12 |
| DTC 112: IAT voltage low | 105 | 4 | DTC 336: CRANK input signal noise | 636 | 2 |
| DTC 111: IAT higher than expected stage 1 | 105 | 15 | DTC 337: Crank signal loss | 636 | 4 |

DIAGNOSTIC TROUBLE CODE (DTC) CHART – SORTED BY SPN:FMI (2 of 4)

| Description | DTC Set 2 | | Description | DTC Set 2 | |
|---|------------|----------|---|-----------|-------|
| | SPN-2 | FMI-2 | | SPN-2 | FMI-2 |
| DTC 16: Crank and/or cam could not synchronize du | 636 | 8 | DTC 1661: PWM6 open / ground short | 925 | 5 |
| DTC 1629: J1939 TSC1 message receipt loss | 639 | 9 | DTC 1664: PWM7 short to power | 926 | 3 |
| DTC 1626: CAN-J1939 Tx fault | 639 | 12 | DTC 1663: PWM7 open / ground short | 926 | 5 |
| DTC 1627: CAN-J1939 Rx fault | 639 | 12 | DTC 643: Sensor supply voltage 1 high | 1079 | 3 |
| DTC 1628: J1939 CAN address / engine-number co | 639 | 13 | DTC 642: Sensor supply voltage 1 low | 1079 | 4 |
| DTC 2619: Tach output short to power | 645 | 3 | DTC 1611: Sensor supply voltage 1 and 2 out-of-range | 1079 | 31 |
| DTC 2618: Tach output ground short | 645 | 4 | DTC 653: Sensor supply voltage 2 high | 1080 | 3 |
| DTC 261: Injector 1 open or short to ground | 651 | 5 | DTC 652: Sensor supply voltage 2 low | 1080 | 4 |
| DTC 262: Injector 1 coil shorted | 651 | 6 | DTC 238: TIP high voltage | 1127 | 3 |
| DTC 264: Injector 2 open or short to ground | 652 | 5 | DTC 237: TIP low voltage | 1127 | 4 |
| DTC 265: Injector 2 coil shorted | 652 | 6 | DTC 1131: WGP voltage high | 1192 | 3 |
| DTC 267: Injector 3 open or short to ground | 653 | 5 | DTC 1132: WGP voltage low | 1192 | 4 |
| DTC 268: Injector 3 coil shorted | 653 | 6 | DTC 1645: MIL control short to power | 1213 | 3 |
| DTC 270: Injector 4 open or short to ground | 654 | 5 | DTC 1644: MIL control ground short | 1213 | 4 |
| DTC 271: Injector 4 coil shorted | 654 | 6 | DTC 650: MIL open | 1213 | 5 |
| DTC 273: Injector 5 open or short to ground | 655 | 5 | DTC 359: Fuel run-out longer than expected | 1239 | 7 |
| DTC 274: Injector 5 coil shorted | 655 | 6 | DTC 2300: Spark coil 1 primary open or short to ground | 1268 | 5 |
| DTC 276: Injector 6 open or short to ground | 656 | 5 | DTC 2301: Spark coil 1 primary shorted | 1268 | 6 |
| DTC 277: Injector 6 coil shorted | 656 | 6 | DTC 2303: Spark coil 2 primary open or short to ground | 1269 | 5 |
| DTC 279: Injector 7 open or short to ground | 657 | 5 | DTC 2304: Spark coil 2 primary shorted | 1269 | 6 |
| DTC 280: Injector 7 coil shorted | 657 | 6 | DTC 2306: Spark coil 3 primary open or short to ground | 1270 | 5 |
| DTC 282: Injector 8 open or short to ground | 658 | 5 | DTC 2307: Spark coil 3 primary shorted | 1270 | 6 |
| DTC 283: Injector 8 coil shorted | 658 | 6 | DTC 2309: Spark coil 4 primary open or short to ground | 1271 | 5 |
| DTC 285: Injector 9 open or short to ground | 659 | 5 | DTC 2310: Spark coil 4 primary shorted | 1271 | 6 |
| DTC 286: Injector 9 coil shorted | 659 | 6 | DTC 2312: Spark coil 5 primary open or short to ground | 1272 | 5 |
| DTC 288: Injector 10 open or short to ground | 660 | 5 | DTC 2313: Spark coil 5 primary shorted | 1272 | 6 |
| DTC 289: Injector 10 coil shorted | 660 | 6 | DTC 2315: Spark coil 6 primary open or short to ground | 1273 | 5 |
| DTC 1631: PWM1-Gauge1 open / ground short | 697 | 5 | DTC 2316: Spark coil 6 primary shorted | 1273 | 6 |
| DTC 1632: PWM1-Gauge1 short to power | 697 | 6 | DTC 2318: Spark coil 7 primary open or short to ground | 1274 | 5 |
| DTC 1633: PWM2-Gauge2 open / ground short | 698 | 5 | DTC 2319: Spark coil 7 primary shorted | 1274 | 6 |
| DTC 1634: PWM2-Gauge2 short to power | 698 | 6 | DTC 2321: Spark coil 8 primary open or short to ground | 1275 | 5 |
| DTC 1635: PWM3-Gauge3 open / ground short | 699 | 5 | DTC 2322: Spark coil 8 primary shorted | 1275 | 6 |
| DTC 1636: PWM3-Gauge3 short to power | 699 | 6 | DTC 2324: Spark coil 9 primary open or short to ground | 1276 | 5 |
| DTC 1637: PWM4 open / ground short | 700 | 5 | DTC 2325: Spark coil 9 primary shorted | 1276 | 6 |
| DTC 1638: PWM4 short to power | 700 | 6 | DTC 2327: Spark coil 10 primary open or short to ground | 1277 | 5 |
| DTC 1547: AUX analog Pull-Up/Down 4 high voltage | 713 | 3 | DTC 2328: Spark coil 10 primary shorted | 1277 | 6 |
| DTC 1548: AUX analog Pull-Up/Down 4 low voltage | 713 | 4 | DTC 617: Start relay coil short to power | 1321 | 3 |
| DTC 341: CAM input signal noise | 723 | 2 | DTC 616: Start relay ground short | 1321 | 4 |
| DTC 342: Loss of CAM input signal | 723 | 4 | DTC 615: Start relay coil open | 1321 | 5 |
| DTC 134: EGO1 open / lazy | 724 | 10 | DTC 1311: Cylinder 1 misfire detected | 1323 | 11 |
| DTC 326: Knock1 excessive or erratic signal | 731 | 2 | DTC 301: Cylinder 1 emissions/catalyst damaging misfire | 1323 | 31 |
| DTC 327: Knock1 sensor open or not present | 731 | 4 | DTC 1312: Cylinder 2 misfire detected | 1324 | 11 |
| DTC 1643: Buzzer control short to power | 920 | 3 | DTC 302: Cylinder 2 emissions/catalyst damaging misfire | 1324 | 31 |
| DTC 1641: Buzzer control ground short | 920 | 4 | DTC 1313: Cylinder 3 misfire detected | 1325 | 11 |
| DTC 1642: Buzzer open | 920 | 5 | DTC 303: Cylinder 3 emissions/catalyst damaging misfire | 1325 | 31 |
| DTC 1662: PWM6 short to power | 925 | 3 | DTC 1314: Cylinder 4 misfire detected | 1326 | 11 |

DIAGNOSTIC TROUBLE CODE (DTC) CHART – SORTED BY SPN:FMI (3 of 4)

| Description | DTC Set 2 | | Description | DTC Set 2 | |
|--|-----------|-------|--|-----------|-------|
| | SPN-2 | FMI-2 | | SPN-2 | FMI-2 |
| DTC 304: Cylinder 4 emissions/catalyst damaging m | 1326 | 31 | DTC 175: Adaptive-learn gasoline bank2 low | 520201 | 1 |
| DTC 1315: Cylinder 5 misfire detected | 1327 | 11 | DTC 1161: Adaptive-learn LPG high | 520202 | 0 |
| DTC 305: Cylinder 5 emissions/catalyst damaging m | 1327 | 31 | DTC 1162: Adaptive-learn LPG low | 520202 | 1 |
| DTC 1316: Cylinder 6 misfire detected | 1328 | 11 | DTC 1163: Adaptive-learn NG high | 520203 | 0 |
| DTC 306: Cylinder 6 emissions/catalyst damaging m | 1328 | 31 | DTC 1164: Adaptive-learn NG low | 520203 | 1 |
| DTC 1317: Cylinder 7 misfire detected | 1329 | 11 | DTC 1155: Closed-loop gasoline bank1 high | 520204 | 0 |
| DTC 307: Cylinder 7 emissions/catalyst damaging m | 1329 | 31 | DTC 1156: Closed-loop gasoline bank1 low | 520204 | 1 |
| DTC 1318: Cylinder 8 misfire detected | 1330 | 11 | DTC 1157: Closed-loop gasoline bank2 high | 520205 | 0 |
| DTC 308: Cylinder 8 emissions/catalyst damaging m | 1330 | 31 | DTC 1158: Closed-loop gasoline bank2 low | 520205 | 1 |
| DTC 628: Fuel-pump high-side open or short to grou | 1347 | 5 | DTC 1151: Closed-loop LPG high | 520206 | 0 |
| DTC 629: Fuel-pump high-side short to power | 1347 | 6 | DTC 1152: Closed-loop LPG low | 520206 | 1 |
| DTC 629: Fuel pump relay coil short to power | 1348 | 3 | DTC 1153: Closed-loop NG high | 520207 | 0 |
| DTC 628: Fuel pump relay control ground short | 1348 | 4 | DTC 1154: Closed-loop NG low | 520207 | 1 |
| DTC 627: Fuel pump relay coil open | 1348 | 5 | DTC 154: EGO2 open / lazy | 520208 | 10 |
| DTC 1625: J1939 shutdown request | 1384 | 31 | DTC 140: EGO3 open / lazy | 520209 | 10 |
| DTC 687: Power relay coil short to power | 1485 | 3 | DTC 160: EGO4 open / lazy | 520210 | 10 |
| DTC 686: Power relay ground short | 1485 | 4 | DTC 420: Catalyst inactive on gasoline (Bank 1) | 520211 | 10 |
| DTC 685: Power relay coil open | 1485 | 5 | DTC 430: Catalyst inactive on gasoline (Bank 2) | 520212 | 10 |
| DTC 234: Boost control overboost failure | 1692 | 0 | DTC 1165: Catalyst inactive on LPG | 520213 | 10 |
| DTC 299: Boost control underboost failure | 1692 | 1 | DTC 1166: Catalyst inactive on NG | 520214 | 10 |
| DTC 236: TIP active | 1692 | 2 | DTC 1515: AUX analog Pull-Down 1 high voltage | 520215 | 3 |
| DTC 1666: PWM8 short to power | 2646 | 3 | DTC 1516: AUX analog Pull-Down 1 low voltage | 520215 | 4 |
| DTC 1665: PWM8 open / ground short | 2646 | 5 | DTC 1511: AUX analog Pull-Up 1 high voltage | 520216 | 3 |
| DTC 1670: PWM9 short to power | 2647 | 3 | DTC 1512: AUX analog Pull-Up 1 low voltage | 520216 | 4 |
| DTC 1669: PWM9 open / ground short | 2647 | 5 | DTC 1513: AUX analog Pull-Up 2 high voltage | 520217 | 3 |
| DTC 8906: UEGO return voltage shorted high | 3056 | 3 | DTC 1514: AUX analog Pull-Up 2 low voltage | 520217 | 4 |
| DTC 8907: UEGO return voltage shorted low | 3056 | 4 | DTC 1517: AUX analog Pull-Up 3 high voltage | 520218 | 3 |
| DTC 8910: UEGO sense cell voltage high | 3217 | 3 | DTC 1518: AUX analog Pull-Up 3 low voltage | 520218 | 4 |
| DTC 8911: UEGO sense cell voltage low | 3217 | 4 | DTC 1541: AUX analog Pull-Up/Down 1 high voltage | 520219 | 3 |
| DTC 8908: UEGO pump voltage shorted high | 3218 | 3 | DTC 1542: AUX analog Pull-Up/Down 1 low voltage | 520219 | 4 |
| DTC 8909: UEGO pump voltage shorted low | 3218 | 4 | DTC 1543: AUX analog Pull-Up/Down 2 high voltage | 520220 | 3 |
| DTC 8904: UEGO cal resistor voltage high | 3221 | 3 | DTC 1544: AUX analog Pull-Up/Down 2 low voltage | 520220 | 4 |
| DTC 8905: UEGO cal resistor voltage low | 3221 | 4 | DTC 1545: AUX analog Pull-Up/Down 3 high voltage | 520221 | 3 |
| DTC 8901: UEGO microprocessor internal fault | 3221 | 31 | DTC 1546: AUX analog Pull-Up/Down 3 low voltage | 520221 | 4 |
| DTC 8916: UEGO sense cell impedance high | 3222 | 0 | DTC 1551: AUX digital 1 high voltage | 520222 | 3 |
| DTC 8902: UEGO heater supply high voltage | 3222 | 3 | DTC 1552: AUX digital 1 low voltage | 520222 | 4 |
| DTC 8903: UEGO heater supply low voltage | 3222 | 4 | DTC 1553: AUX digital 2 high voltage | 520223 | 3 |
| DTC 8914: UEGO sense cell slow to warm up | 3222 | 10 | DTC 1554: AUX digital 2 low voltage | 520223 | 4 |
| DTC 8917: UEGO pump cell impedance high | 3225 | 0 | DTC 1555: AUX digital 3 high voltage | 520224 | 3 |
| DTC 8918: UEGO pump cell impedance low | 3225 | 1 | DTC 1555: Water Intrusion Detection | 520224 | 3 |
| DTC 8912: UEGO pump voltage at high drive limit | 3225 | 3 | DTC 1556: AUX digital 3 low voltage | 520224 | 4 |
| DTC 8913: UEGO pump voltage at low drive limit | 3225 | 4 | DTC 916: Shift actuator feedback out-of-range | 520226 | 3 |
| DTC 8915: UEGO pump cell slow to warm up | 3225 | 10 | DTC 919: Shift unable to reach desired gear | 520226 | 7 |
| DTC 171: Adaptive-learn gasoline bank1 high | 520200 | 0 | DTC 920: Shift actuator or drive circuit failed | 520226 | 31 |
| DTC 172: Adaptive-learn gasoline bank1 low | 520200 | 1 | DTC 1639: PWM5 open / ground short | 520230 | 5 |
| DTC 174: Adaptive-learn gasoline bank2 high | 520201 | 0 | DTC 1640: PWM5 short to power | 520230 | 6 |

DIAGNOSTIC TROUBLE CODE (DTC) CHART – SORTED BY SPN:FMI 4 of 4

| Description | DTC Set 2 | |
|---|-----------|-------|
| | SPN-2 | FMI-2 |
| DTC 188: Gaseous fuel temperature sender high voltage | 520240 | 3 |
| DTC 187: Gaseous fuel temperature sender low voltage | 520240 | 4 |
| DTC 331: Knock2 excessive or erratic signal | 520241 | 2 |
| DTC 332: Knock2 sensor open or not present | 520241 | 4 |
| DTC 2120: FPP1 invalid voltage and FPP2 disagree | 520250 | 31 |
| DTC 2125: FPP2 invalid voltage and FPP1 disagree | 520250 | 31 |
| DTC 1122: FPP1/2 do not match each other or IVS (| 520250 | 31 |
| DTC 223: TPS2 voltage high | 520251 | 3 |
| DTC 222: TPS2 voltage low | 520251 | 4 |
| DTC 509: IAC coil open/short | 520252 | 5 |
| DTC 508: IAC ground short | 520252 | 6 |
| DTC 1171: MegaJector delivery pressure higher than | 520260 | 0 |
| DTC 1172: MegaJector delivery pressure lower than | 520260 | 1 |
| DTC 1174: MegaJector voltage supply high | 520260 | 3 |
| DTC 1175: MegaJector voltage supply low | 520260 | 4 |
| DTC 1176: MegaJector internal actuator fault detecti | 520260 | 12 |
| DTC 1177: MegaJector internal circuitry fault detecti | 520260 | 12 |
| DTC 1178: MegaJector internal comm fault detection | 520260 | 12 |
| DTC 1173: MegaJector comm lost | 520260 | 31 |
| DTC 1531: Gov1/2/3 interlock failure | 520270 | 31 |
| DTC 1182: Fuel impurity level high | 520401 | 0 |
| DTC 11: Intake cam / distributor position error | 520800 | 7 |
| DTC 24: Exhaust cam position error | 520801 | 7 |
| DTC 1183: MegaJector autozero / lockoff failure | 520803 | 31 |

OBD System Check/MIL (Malfunction Indicator Lamp)

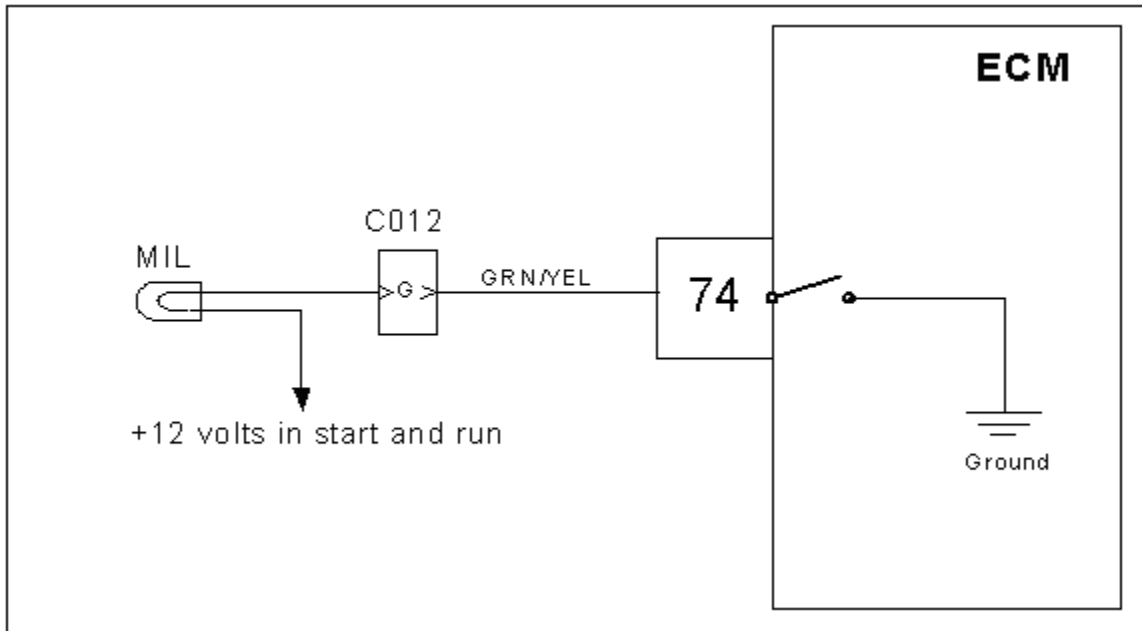

Circuit Description

The fuel system is equipped with OBD (On-Board Diagnostics). The system has a dash mounted MIL (Malfunction Indicator Lamp). The MIL serves as notification of an engine or fuel system related problem. The MIL also has the ability to flash DTC codes in what is referred to as the blink code mode. It will display DTCs that have been stored due to a possible system malfunction. The following DTC charts in this manual will instruct the technician to perform the OBD system check. This simply means to verify the operation of the MIL. The lamp should illuminate when the key is in the ON position, and the engine is not running. This feature verifies that the lamp is in proper working order. If the lamp does not illuminate with the vehicle key ON and engine OFF, repair it as soon as possible. Once the engine is in start or run mode, the lamp should go off. If the lamp stays on while the engine is in the start or run mode, a current diagnostic trouble code may be set or a problem may exist with the MIL electrical wiring. The electrical schematic above shows the MIL power source supplied to the lamp. The ECM completes the circuit to ground to turn the lamp ON.

DTC 107-MAP Low Voltage

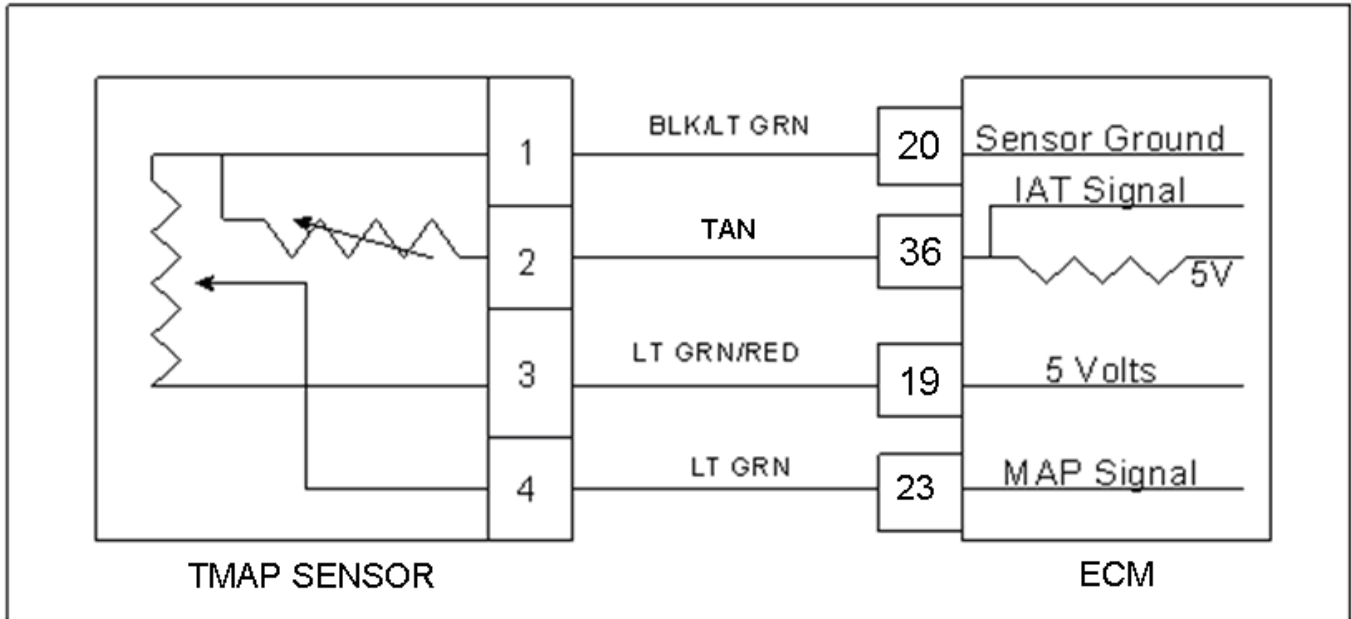

Conditions for Setting the DTC

- Manifold Absolute Pressure Sensor
- Check Condition-Engine cranking or running
- Fault Condition-MAP voltage less than 0.050 with throttle position greater than 2.0% and engine RPM less than 7000.
- MIL-ON
- Adaptive-Disabled
- Fueling is based on RPM and TPS Limp-Home Condition during this fault.

Circuit Description

The Manifold Absolute Pressure sensor is a pressure transducer connected to the intake manifold. It is used to measure the pressure of air in the manifold prior to induction. The pressure reading is used in conjunction with other inputs to estimate the airflow rate to the engine, which determines the fuel flow rate. This fault will set if the MAP voltage is less than 0.050 with TPS greater than 2% and engine RPM is less than 7000. The Adaptive Learn will be disabled for the remainder of the key on cycle and the MIL command is on.

DTC 107-MAP Low Voltage

| Step | Action | Value(s) | Yes | No |
|------|--|----------|--|--|
| 1 | Did you perform the On-Board (OBD) System Check? | - | Go to Step (2) | Go to OBD System Check Section |
| 2 | <ul style="list-style-type: none"> • Key ON, Engine running. • DSC (Diagnostic Scan Tool) connected in System Data Mode Does DST display MAP voltage of 0.050 or less with the engine running below 7000 rpm and TPS above 2.0 %? | | Go to Step (3) | Intermittent problem Go to Intermittent section |
| 3 | <ul style="list-style-type: none"> • Key OFF • Disconnect the MAP sensor connector C006 from the wiring harness • Jump the 5 volt reference pin 3 and MAP signal circuit pin 4 together • Key ON Does the DST display MAP voltage of 4.5 volts or greater? | | Go to Step (4) | Go to Step (8) |
| 4 | <ul style="list-style-type: none"> • Inspect MAP connector and pins for corrosion, contamination or mechanical damage Any problems found? | | Repair the circuit as necessary. Refer to Wiring Repairs in Engine Electrical. | Go to Step (5) |
| 5 | <ul style="list-style-type: none"> • Key OFF • Disconnect ECM connector C001 • Check for continuity between MAP sensor connector signal pin 4 and ECM MAP signal pin 23. Do you have continuity between them? | | Go to Step (6) | Repair the circuit as necessary. Refer to Wiring Repairs in Engine Electrical. |
| 6 | <ul style="list-style-type: none"> • Check for continuity between MAP sensor connector 5 volt supply signal pin 3 and ECM 5 volt supply pin 19 Do you have continuity between them? | | Go to Step (7) | Repair the circuit as necessary. Refer to Wiring Repairs in Engine Electrical. |
| 7 | <ul style="list-style-type: none"> • Check for continuity between MAP sensor connector ground pin 1 and ECM sensor ground pin 20 Do you have continuity between them? | | Go to Step (17) | Repair the circuit as necessary. Refer to Wiring Repairs in Engine Electrical. |

| Step | Action | Value(s) | Yes | No |
|------|--|----------|--|--|
| 8 | <ul style="list-style-type: none"> Probe MAP connector signal circuit pin 4 with a test light connected to battery voltage. Does the DST display MAP voltage of 4.0 or greater? | | Go to Step (9) | Go to Step (13) |
| 9 | <ul style="list-style-type: none"> Key OFF Disconnect ECM connector Check for continuity between MAP sensor connector pin 3 and ECM 5 volt pin 19. Do you have continuity between them? | | Go to Step (10) | Repair the circuit as necessary. Refer to Wiring Repairs in Engine Electrical. |
| 10 | <ul style="list-style-type: none"> Check for continuity between MAP sensor connector 5 volt reference pin 3 and engine ground Do you have continuity? | | Repair the circuit as necessary. Refer to Wiring Repairs in Engine Electrical. | Go to Step (11) |
| 11 | <ul style="list-style-type: none"> Inspect ECM and MAP wire harness connector and terminals for corrosion, contamination or mechanical damage Any problems found? | | Repair the circuit as necessary. Refer to Wiring Repairs in Engine Electrical. | Go to Step (16) |
| 12 | <ul style="list-style-type: none"> Replace ECM. Refer to ECM replacement in the Engine Controls Section. Is the replacement complete? | | Go to Step (17) | - |
| 13 | <ul style="list-style-type: none"> Disconnect ECM connector Check for continuity between MAP sensor connector signal circuit pin 4 and ECM signal pin 23 Do you have continuity between them? | | Go to Step (14) | Repair the circuit as necessary. Refer to Wiring Repairs in Engine Electrical. |
| 14 | <ul style="list-style-type: none"> Check for continuity between MAP sensor connector signal pin 4 and engine ground Do you have continuity? | | Repair the circuit as necessary. Refer to Wiring Repairs in Engine Electrical. | Go to Step (15) |
| 15 | <ul style="list-style-type: none"> Inspect ECM connector and wire harness connector terminals for corrosion, contamination or mechanical damage Any problems found? | | Repair the circuit as necessary. Refer to Wiring Repairs in Engine Electrical. | Go to Step (16) |

| Step | Action | Value(s) | Yes | No |
|------|--|----------|-----------------|------------------------|
| 16 | <ul style="list-style-type: none"> Replace ECM. Refer to ECM replacement in the Engine Controls Section. Is the replacement complete? | | Go to Step (18) | - |
| 17 | <ul style="list-style-type: none"> Replace MAP sensor Is the replacement complete? | | Go to Step (18) | - |
| 18 | <ul style="list-style-type: none"> Remove all test equipment except the DST. Connect any disconnected components, fuses, etc. Using the DST clear DTC information from the ECM. Turn the ignition OFF and wait 30 seconds. Start the engine and operate the vehicle to full operating temperature Observe the MIL Observe engine performance and drivability After operating the engine within the test parameters of DTC-107 check for any stored codes. Does the engine operate normally with no stored codes? | | System OK | Go to OBD System Check |

DTC 108-MAP High Pressure

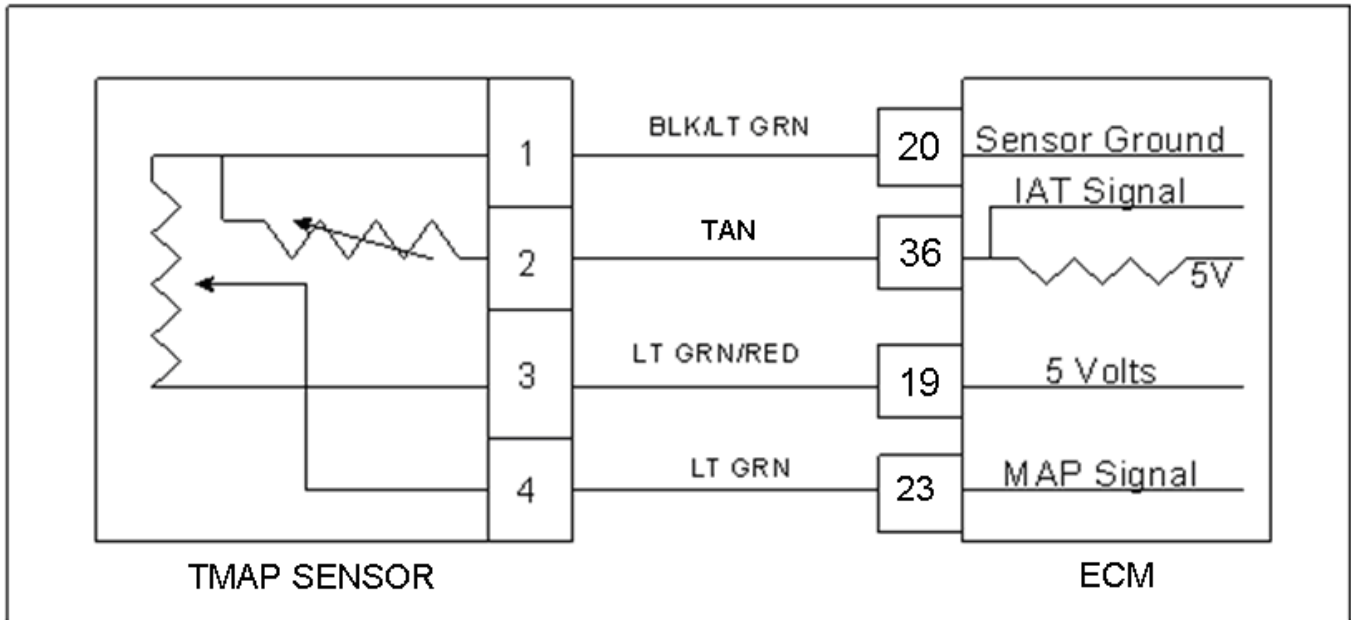

Conditions for Setting the DTC

- MAP pressure test
- Check condition-engine running
- Fault Condition-MAP greater than 35 PSIA with TPS less than 10% and engine rpm greater than 1400.
- MIL-ON
- Adaptive-disabled

Circuit Description

The MAP (Manifold Absolute Pressure) is estimated from the MAP sensor. The MAP pressure value is used for fuel, airflow and spark calculations. This fault will set in the event the MAP value is greater than 35 PSIA when the TPS is less than 10% with engine rpm greater than 1400.

DTC 108-MAP High Pressure

| Step | Action | Value(s) | Yes | No |
|------|--|----------|-----------------|---|
| 1 | Did you perform the On-Board (OBD) System Check? | - | Go to Step (2) | Go to OBD System Check Section |
| 2 | <ul style="list-style-type: none"> • Key ON, Engine running at full operating temperature. • DST (Diagnostic Scan Tool) connected in System Data Mode Does DST display MAP pressure of 35 PSIA or greater with the engine running above 1400 rpm with a TPS value less than 10%? | | Go to Step (3) | Intermittent problem Go to Intermittent section |
| 3 | <ul style="list-style-type: none"> • Key OFF • Disconnect the MAP sensor connector C006 • Key ON Does the DST display MAP pressure less than 0.05 psia? | | Go to Step (4) | Go to Step (6) |
| 4 | <ul style="list-style-type: none"> • Probe MAP connector ground pin 1 with a test light connected to battery voltage. Does the test light come on? | | Go to Step (5) | Go to Step (8) |
| 5 | <ul style="list-style-type: none"> • Check MAP mechanical vacuum connection for correct mounting or possible damage causing leakage. Is the MAP sensor mechanical connection OK? | | Go to Step (6) | Go to Step (10) |
| 6 | <ul style="list-style-type: none"> • Key OFF • Disconnect ECM connector and inspect terminals for damage corrosion or contamination. Is the connection OK? | | Go to Step (7) | Repair the circuit as necessary. Refer to Wiring Repairs in Engine Electrical. |
| 7 | <ul style="list-style-type: none"> • Replace MAP sensor. Is the repair complete? | — | Go to Step (11) | - |

| Step | Action | Value(s) | Yes | No |
|------|--|----------|-----------------|--|
| 8 | <ul style="list-style-type: none"> Disconnect ECM connector and check for continuity between MAP connector sensor ground pin 1 and ECM sensor ground pin 20. Do you have continuity between them? | | Go to Step (9) | Repair the circuit as necessary. Refer to Wiring Repairs in Engine Electrical. |
| 9 | <ul style="list-style-type: none"> Replace ECM. Refer to ECM replacement in the Engine Controls Section. Is the replacement complete? | | Go to Step (11) | - |
| 10 | <ul style="list-style-type: none"> Correct MAP mechanical connection Has the MAP mechanical connection problem been corrected? | | Go to Step (11) | - |
| 11 | <ul style="list-style-type: none"> Remove all test equipment except the DST. Connect any disconnected components, fuses, etc. Using the DST clear DTC information from the ECM. Turn the ignition OFF and wait 30 seconds. Start the engine and operate the vehicle to full operating temperature Observe the MIL Observe engine performance and drivability After operating the engine within the test parameters of DTC-108 check for any stored codes. Does the engine operate normally with no stored codes? | | System OK | Go to OBD System Check |

DTC 111-IAT Higher Than Expected 1

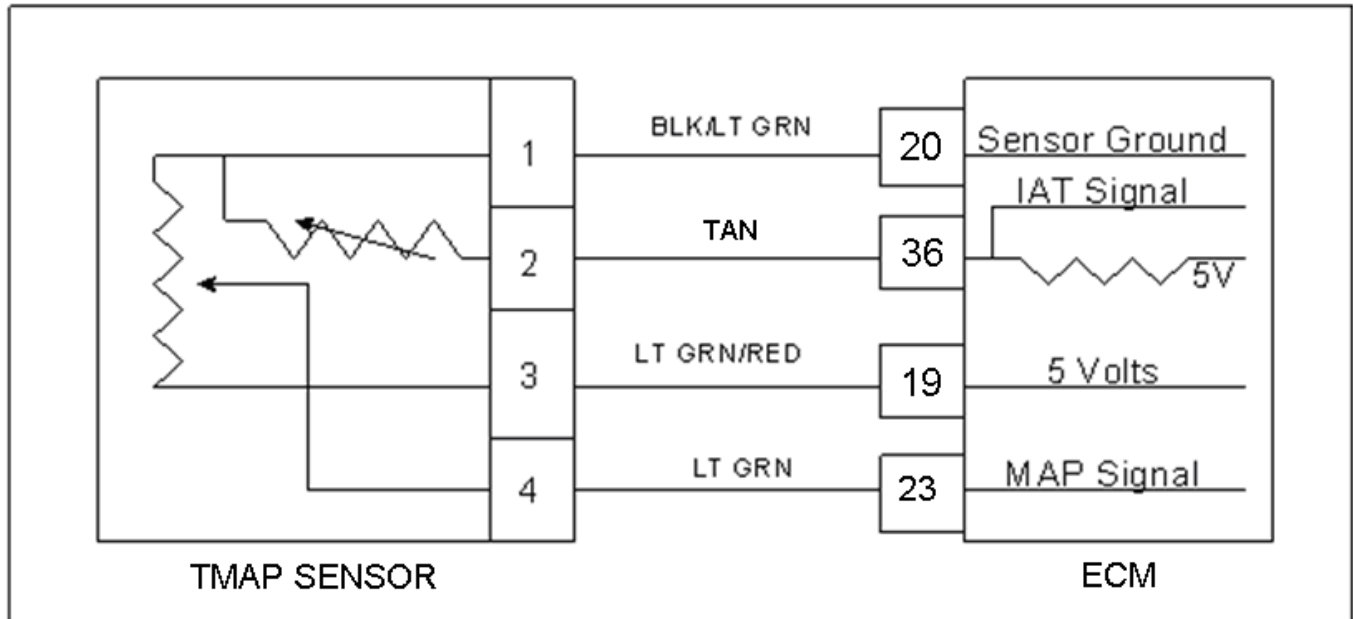

Conditions for Setting the DTC

- Intake Air Temperature
- Check Condition-Engine Running
- Fault Condition-Intake Air Temperature greater than 140 degrees F. with engine rpm greater than 1200rpm
- Condition must be present for a minimum of 30 seconds
- MIL-ON
- Adaptive-Disabled during active fault
- Hard Warning

Circuit Description

The TMAP is a combined IAT (Intake Air Temperature) and MAP (Manifold Absolute Pressure) sensor. A temperature sensitive resistor is used in the TMAP located in the air intake manifold of the engine. It is used to monitor incoming air temperature, and the output in conjunction with other sensors is used to determine the airflow to the engine. The ECM provides a voltage divider circuit so that when the air is cool, the signal reads higher voltage, and lower when warm. This fault will set if the Intake Air Temperature is greater than 140 degrees F. with engine speed greater than 1200 rpm.

DTC 111-IAT Higher Than Expected 1

Diagnostic Aid

This fault will set when inlet air is much hotter than normal. The most common cause of high inlet air temperature is a problem with the inlet air system.

- Ensure that the air inlet is not obstructed, modified or damaged.
- Inspect the air inlet system for cracks or breaks that may allow unwanted under hood air in to the air inlet system
- If none of the above can be found, follow the diagnostic steps for DTC 112-IAT Low Voltage.

DTC 112-IAT Low Voltage

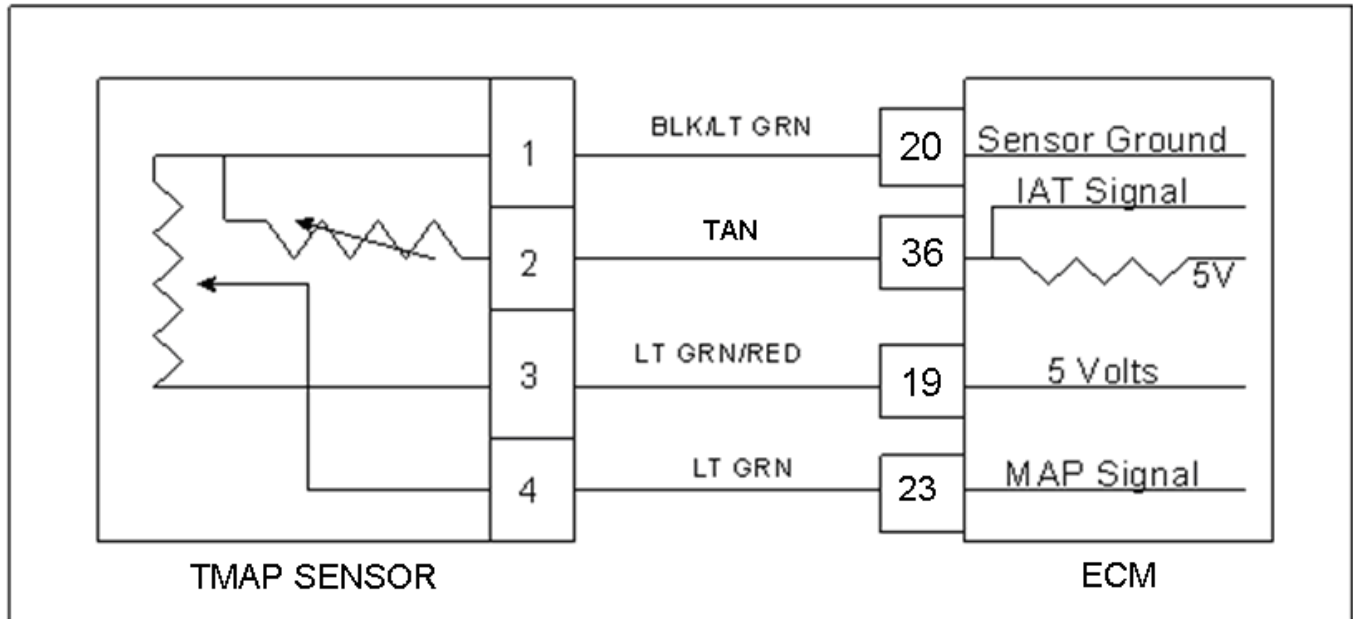

Conditions for Setting the DTC

- Intake Air Temperature
- Check Condition Engine Cranking or Running
- Fault Condition-IAT Sensor Voltage less than 0.050
- MIL-ON during active fault
- Adaptive-Disabled during active fault

Circuit Description

The TMAP is a combined IAT (Intake Air Temperature) and MAP (Manifold Absolute Pressure) sensor. A temperature sensitive resistor is used in the TMAP is located in the engine's air intake or intake manifold. It is used to monitor incoming air temperature, and the output in conjunction with other sensors is used to determine the airflow to the engine. The ECM provides a voltage divider circuit so that when the air is cool the signal reads higher voltage, and lower when warm. This fault will set if the signal voltage is less than 0.050 volts for 1 second anytime the engine is cranking or running. The ECM will use the default value for the IAT sensor in the event of this fault.

DTC 112-IAT Voltage Low

| Step | Action | Value(s) | Yes | No |
|------|--|----------|---|--|
| 1 | Did you perform the On-Board (OBD) System Check? | — | Go to Step (2) | Go to OBD System Check Section |
| 2 | <ul style="list-style-type: none"> • Key ON • DST (Diagnostic Scan Tool) connected in System Data Mode Does DST display IAT voltage of 0.050 or less? | | Go to Step (3) | Intermittent problem Go to Intermittent section |
| 3 | <ul style="list-style-type: none"> • Key OFF • Disconnect the TMAP sensor connector. • Key ON Does the DST display IAT voltage of 4.90 volts or greater? | | Go to Step (4) | Go to Step (5) |
| 4 | <ul style="list-style-type: none"> • Replace TMAP sensor. Is the replacement complete? | | Go to Step (9) | — |
| 5 | <ul style="list-style-type: none"> • Key OFF • Disconnect ECM wire harness connector C001 • Check for continuity between TMAP sensor connector ground pin 1 and TMAP sensor connector signal pin 2 Do you have continuity between them? | — | Repair the circuit as necessary. Refer to Wiring Repairs in Engine Electrical. | Go to Step (6) |
| 6 | <ul style="list-style-type: none"> • Check for continuity between TMAP sensor connector signal circuit pin 2 and engine ground. Do you have continuity? | — | Repair the circuit as necessary. Refer to Wiring Repairs in Engine Electrical. | Go to Step (7) |

| Step | Action | Value(s) | Yes | No |
|------|--|----------|----------------|------------------------|
| 7 | <ul style="list-style-type: none"> Replace ECM. Refer to ECM replacement in the Engine Controls Section. Is the replacement complete? | – | Go to Step (8) | – |
| 8 | <ul style="list-style-type: none"> Remove all test equipment except the DST. Connect any disconnected components, fuses, etc. Using the DST clear DTC information from the ECM. Turn the ignition OFF and wait 30 seconds. Start the engine and operate the vehicle to full operating temperature Observe the MIL Observe engine performance and drivability After operating the engine within the test parameters of DTC-112 check for any stored codes. Does the engine operate normally with no stored codes? | | System OK | Go to OBD System Check |

DTC 113-IAT High Voltage

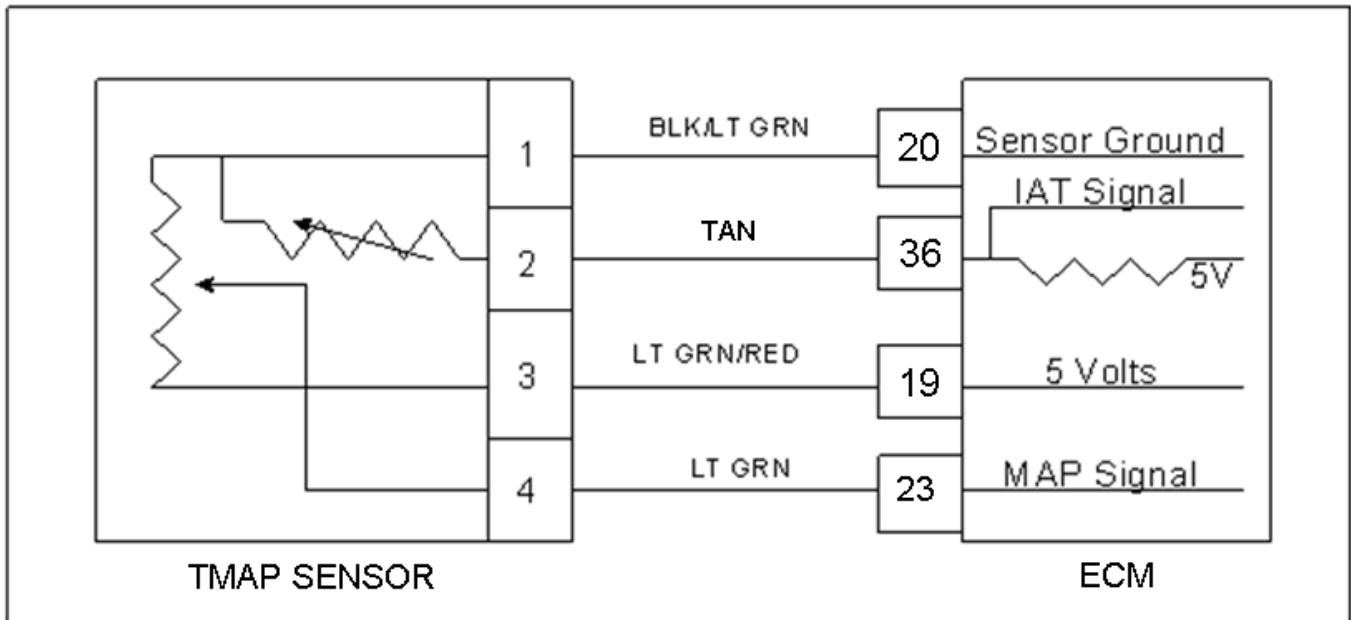

Conditions for Setting the DTC

- Intake Air Temperature
- Check Condition-Engine Running
- Fault Condition-IAT Sensor Voltage greater than 4.950 volts
- MIL-ON during active fault
- Adaptive-Disabled during active fault

Circuit Description

The TMAP is a combined IAT (Intake Air Temperature) and MAP (Manifold Absolute Pressure) sensor. A temperature sensitive resistor is used in the TMAP is located in the engine's air intake or intake manifold.. It is used to monitor incoming air temperature, and the output in conjunction with other sensors is used to determine the airflow to the engine. The ECM provides a voltage divider circuit so that when the air is cool, the signal reads higher voltage, and lower when warm. This fault will set if the signal voltage is greater than 4.950 volts for 1 second or longer. The ECM will use a default value for the IAT sensor in the event of this fault.

DTC 113-IAT Voltage High

| Step | Action | Value(s) | Yes | No |
|------|--|----------|-----------------|--|
| 1 | Did you perform the On-Board (OBD) System Check? | - | Go to Step (2) | Go to OBD System Check Section |
| 2 | <ul style="list-style-type: none"> • Key ON • DST (Diagnostic Scan Tool) connected in System Data Mode Does DST display IAT voltage of 4.950 or greater? | | Go to Step (3) | Intermittent problem Go to Intermittent section |
| 3 | <ul style="list-style-type: none"> • Key OFF • Disconnect the TMAP sensor connector C006 and jump pins 1 and 2 together • Key ON Does the DST display IAT voltage of 0.1 volts or less? | | Go to Step (9) | Go to Step (4) |
| 4 | <ul style="list-style-type: none"> • Key OFF • Jump TMAP sensor connector signal pin 2 to engine ground • Key ON Does DST display IAT voltage of 0.1 volts or less? | | Go to Step (7) | Go to Step (6) |
| 5 | <ul style="list-style-type: none"> • Replace TMAP sensor. Is the replacement complete? | | Go to Step (11) | - |
| 6 | <ul style="list-style-type: none"> • Key OFF • Disconnect the ECM wire harness connector C001. • Check for continuity between TMAP sensor connector signal pin 2 and ECM IAT signal pin 36 Do you have continuity between them? | — | Go to Step (10) | Repair the circuit as necessary. Refer to Wiring Repairs in Engine Electrical. |
| 7 | <ul style="list-style-type: none"> • Check for continuity between TMAP sensor connector ground circuit pin 1 and ECM sensor ground circuit pin 20 Do you have continuity between them? | — | Go to Step (10) | Repair the circuit as necessary. Refer to Wiring Repairs in Engine Electrical. |

| Step | Action | Value(s) | Yes | No |
|------|--|----------|---|------------------------|
| 8 | <ul style="list-style-type: none"> Replace the ECM. Is the replacement complete? | – | Go to Step (11) | – |
| 9 | <ul style="list-style-type: none"> Re-check wire harness and TMAP sensor connector for damage corrosion or contamination Any problems found? | | Repair the circuit as necessary. Refer to Wiring Repairs in Engine Electrical | Go to Step (5) |
| 10 | <ul style="list-style-type: none"> Re-check wire harness and TMAP sensor connectors for damage corrosion or contamination Any problems found? | | Repair the circuit as necessary. Refer to Wiring Repairs in Engine Electrical | Go to Step (8) |
| 11 | <ul style="list-style-type: none"> Remove all test equipment except the DST. Connect any disconnected components, fuses, etc. Using the DST clear DTC information from the ECM. Turn the ignition OFF and wait 30 seconds. Start the engine and operate the vehicle to full operating temperature Observe the MIL Observe engine performance and drivability After operating the engine within the test parameters of DTC-113 check for any stored codes. Does the engine operate normally with no stored codes? | | System OK | Go to OBD System Check |

DTC 116-ECT Higher Than Expected 1

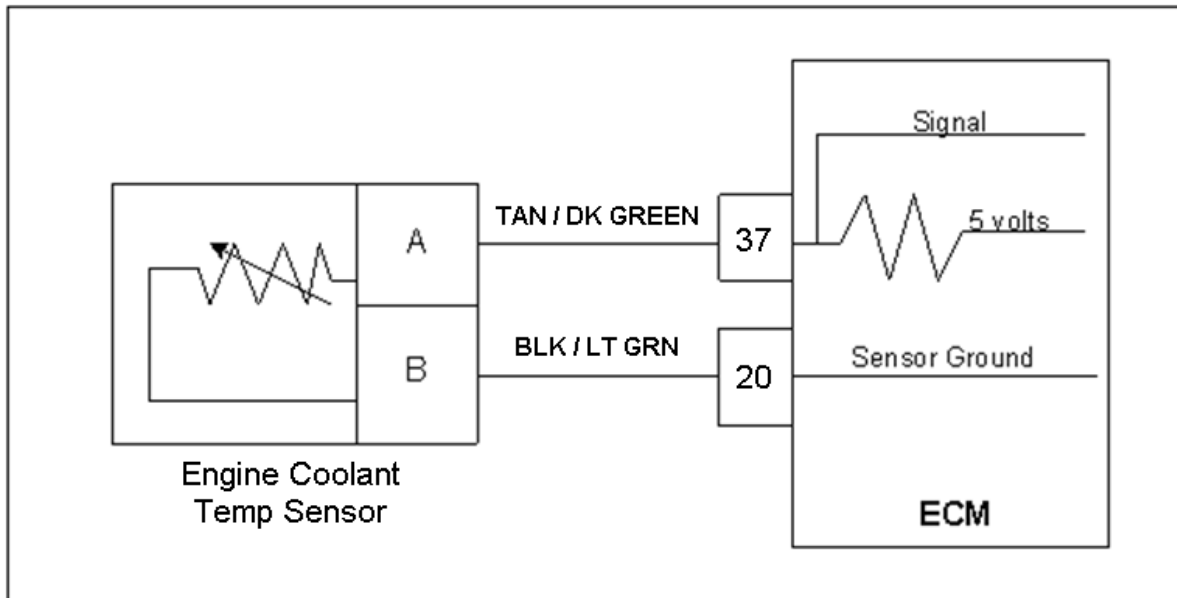

Conditions for Setting the DTC

- Engine Coolant Temperature
- Check Condition-Engine Running
- Fault Condition-Engine Coolant Temperature reading or estimate greater than 220 degrees F. for greater than 15 seconds
- MIL-On
- Power derate (level 1)
- Adaptive-Disabled during active fault

Circuit Description

The ECT (Engine Coolant Temperature) sensor is a temperature sensitive resistor located in the engine coolant passage. The ECT is used for engine airflow calculation, fuel enrichment, and ignition timing control and to enable certain other temperature dependant operations. This code set is designed to help prevent engine damage from overheating. The ECM provides a voltage divider circuit so when the sensor reading is cool the sensor reads higher voltage, and lower when warm. This fault will set when the coolant exceeds 220 degrees F. for more than 15 seconds. Power derate level one will be enforced during this fault limiting the maximum throttle position to 50%.

DTC 116-ECT Higher Than Expected 1

| STEP | Action | Value(s) | Yes |
|------|---|----------|------------------------|
| 1 | Did you perform the On-Board (OBD) System Check? | - | Go to Step (2) |
| 2 | <ul style="list-style-type: none"> • Key ON • DST (Diagnostic Scan Tool) connected in system data mode <p>Warm engine to normal operating temperature, then run the engine above 1200 rpm for at least 60 seconds</p> <p>Does the DST display ECT temperture of 220 degrees F or greater?</p> | | Go to Step (3) |
| 3 | <p>Verify with a temperature gauge that the engine coolant is over 220 degrees F.</p> <p>Does the temperature gauge indicated 220 degrees F. or greater?</p> | | Repair cooling system. |
| 4 | Verify ECT Circuit function. Follow diagnostic test procedure for DTC 217 (ECT Higher than expected 2) | | - |

DTC 117-ECT/CHT Low Voltage

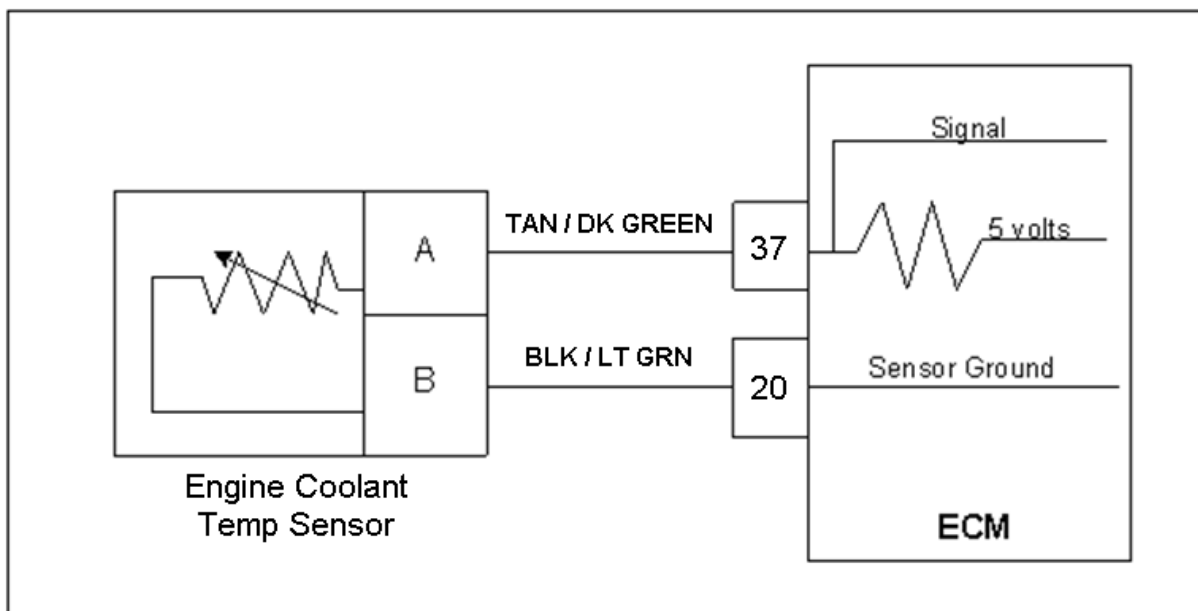

Conditions for Setting the DTC

- Engine Coolant Temperature
- Check Condition-Engine Running
- Fault Condition-ECT sensor voltage less than 0.050
- MIL-ON during active fault
- Adaptive-Disabled during active fault

Circuit Description

The ECT (Engine Coolant Temperature) sensor is a temperature sensitive resistor located in the engine coolant passage. It is used for the engine air-flow calculation, cold fuel enrichment and to enable other temperature dependant features. The ECM provides a voltage divider circuit so that when the coolant is cool, the signal reads higher voltage, and lower when warm (see table). This fault will set if the signal voltage is less than 0.050 volts for any period longer than 1 second. The ECM will use a default value for the ECT sensor in the event of this fault.

| Temp (deg F) | Ohms +/-10% |
|--------------|-------------|
| 242.4 | 101 |
| 231.9 | 121 |
| 211.6 | 175 |
| 201.4 | 209 |
| 181.9 | 302 |
| 163.1 | 434 |
| 144.9 | 625 |
| 127.4 | 901 |
| 102.4 | 1,556 |
| 78.9 | 2,689 |
| 49.9 | 5,576 |
| 23.5 | 11,562 |
| -5.7 | 28,770 |
| -21.2 | 49,715 |
| -30.8 | 71,589 |
| -40.0 | 99,301 |

DTC 117-ECT/CHT Voltage Low

| Step | Action | Value(s) | Yes | No |
|------|--|----------|--|--|
| 1 | Did you perform the On-Board (OBD) System Check? | — | Go to Step (2) | Go to OBD System Check Section |
| 2 | <ul style="list-style-type: none"> • Key ON • DST (Diagnostic Scan Tool) connected in System Data Mode Does DST display ECT voltage of 0.050 or less? | | Go to Step (3) | Intermittent problem Go to Intermittent section |
| 3 | <ul style="list-style-type: none"> • Key OFF • Disconnect the ECT wire harness connector C007 • Key ON Does the DST display ECT voltage of 4.90 volts or greater? | | Go to Step (4) | Go to Step (5) |
| 4 | <ul style="list-style-type: none"> • Replace ECT sensor. Is the replacement complete? | | Go to Step (8) | — |
| 5 | <ul style="list-style-type: none"> • Key OFF • Disconnect ECM wire harness connector C001 • Check for continuity between ECT sensor connector signal pin A and ECT sensor ground pin B Do you have continuity between them? | — | Repair the circuit as necessary. Refer to Wiring Repairs in Engine Electrical. | Go to Step (6) |
| 6 | <ul style="list-style-type: none"> • Check for continuity between ECT sensor connector signal circuit pin A and engine ground. Do you have continuity? | — | Repair the circuit as necessary. Refer to Wiring Repairs in Engine Electrical. | Go to Step (7) |

| Step | Action | Value(s) | Yes | No |
|------|--|----------|----------------|------------------------|
| 7 | <ul style="list-style-type: none"> Replace ECM. Refer to ECM replacement in the Engine Controls Section. Is the replacement complete? | – | Go to Step (8) | – |
| 8 | <ul style="list-style-type: none"> Remove all test equipment except the DST. Connect any disconnected components, fuses, etc. Using the DST clear DTC information from the ECM. Turn the ignition OFF and wait 30 seconds. Start the engine and operate the vehicle to full operating temperature Observe the MIL Observe engine performance and drivability After operating the engine within the test parameters of DTC-117 check for any stored codes. Does the engine operate normally with no stored codes? | | System OK | Go to OBD System Check |

DTC 118-ECT/CHT High Voltage

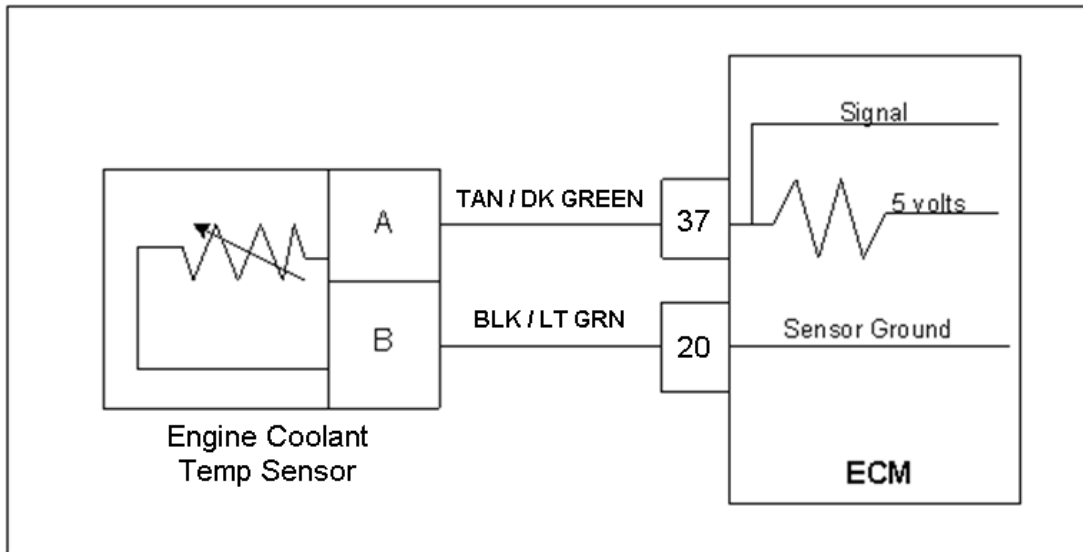

Conditions for Setting the DTC

- Engine Coolant Temperature
- Check Condition-Engine Running
- Fault Condition-ECT sensor voltage exceeds 4.950 volts
- MIL-ON during active fault
- Adaptive-Disabled

Circuit Description

The ECT (Engine Coolant Temperature) sensor is a temperature sensitive resistor located in the engine coolant passage. It is used for the engine airflow calculation, cold fuel enrichment and to enable other temperature dependant features. The ECM provides a voltage divider circuit so that when the coolant is cool, the signal reads higher voltage, and lower when warm (see table). This fault will set if the signal voltage is greater than 4.950 volts anytime the engine is running. The ECM will use a default value for the ECT sensor in the event of this fault.

| Temp (deg F) | Ohms +/-10% |
|--------------|-------------|
| 242.4 | 101 |
| 231.9 | 121 |
| 211.6 | 175 |
| 201.4 | 209 |
| 181.9 | 302 |
| 163.1 | 434 |
| 144.9 | 625 |
| 127.4 | 901 |
| 102.4 | 1,556 |
| 78.9 | 2,689 |
| 49.9 | 5,576 |
| 23.5 | 11,562 |
| -5.7 | 28,770 |
| -21.2 | 49,715 |
| -30.8 | 71,589 |
| -40.0 | 99,301 |

DTC 118-ECT/CHT Voltage High

| Step | Action | Value(s) | Yes | No |
|------|--|---|--|--|
| 1 | Did you perform the On-Board (OBD) System Check? | - | Go to Step (2) | Go to OBD System Check Section |
| 2 | <ul style="list-style-type: none"> • Key ON • DST (Diagnostic Scan Tool) connected in System Data Mode Does DST display ECT voltage of 4.95 or greater? | | Go to Step (3) | Intermittent problem Go to Intermittent section |
| 3 | <ul style="list-style-type: none"> • Key OFF • Disconnect the ECT sensor connector C007 and Jump terminals A and B together • Key ON Does the DST display ECT voltage of 0.05 volts or less? | | Go to Step (4) | Go to Step (8) |
| 4 | <ul style="list-style-type: none"> • Using a DVOM check the resistance between the two terminals of the ECT sensor and compare the resistance reading to the chart Is the resistance value correct? | See resistance chart vs. temperature in the DTC 118 circuit description | Go to Step (6) | Go to Step (5) |
| 5 | <ul style="list-style-type: none"> • Replace ECT sensor Is the replacement complete? | | Go to Step (14) | - |
| 6 | <ul style="list-style-type: none"> • Inspect the ECT wire harness connector terminals A and B for damage, corrosion or contamination Did you find a problem? | | Repair the circuit as necessary. Refer to Wiring Repairs in Engine Electrical. | Go to Step (7) |
| 7 | <ul style="list-style-type: none"> • Key OFF • Disconnect ECM wire harness connector C001 • Inspect ECM connector pins 26 and 3 for damage corrosion or contamination Did you find a problem? | | Repair the circuit as necessary. Refer to Wiring Repairs in Engine Electrical. | Intermittent problem Go to Intermittent section |

| Step | Action | Value(s) | Yes | No |
|------|--|----------|--|--|
| 8 | <ul style="list-style-type: none"> Jump the ECT signal pin A at the ECT connector to engine ground Does DST display ECT voltage of 0.05 or less? | | Go to Step (9) | Go to Step (12) |
| 9 | <ul style="list-style-type: none"> Key OFF Disconnect ECM wire harness connector Using a DVOM check for continuity between ECT sensor ground pin B and ECM connector pin 3 Do you have continuity between them? | | Go to Step (10) | Repair the circuit as necessary. Refer to Wiring Repairs in Engine Electrical. |
| 10 | <ul style="list-style-type: none"> Inspect ECM connector pins 26 and 3 for damage, corrosion or contamination Did you find a problem? | | Repair the circuit as necessary. Refer to Wiring Repairs in Engine Electrical. | Go to Step (11) |
| 11 | <ul style="list-style-type: none"> Replace ECM Is the replacement complete? | | Go to Step (14) | - |
| 12 | <ul style="list-style-type: none"> Key OFF Disconnect ECM wire harness connector Using a DVOM check for continuity between ECT connector signal pin A and ECM connector terminal 26 Do you have continuity between them? | | Go to Step (13) | Repair the circuit as necessary. Refer to Wiring Repairs in Engine Electrical. |
| 13 | <ul style="list-style-type: none"> Inspect ECM connector pins 26 and 3 for damage, corrosion or contamination Did you find a problem? | | Repair the circuit as necessary. Refer to Wiring Repairs in Engine Electrical. | Go to Step (11) |
| 14 | <ul style="list-style-type: none"> Remove all test equipment except the DST. Connect any disconnected components, fuses, etc. Using the DST clear DTC information from the ECM. Turn the ignition OFF and wait 30 seconds. Start the engine and operate the vehicle to full operating temperature Observe the MIL Observe engine performance and drivability After operating the engine within the test parameters of DTC-118 check for any stored codes. Does the engine operate normally with no stored codes? | | System OK | Go to OBD System Check |

DTC 121-TPS 1 Lower Than TPS 2

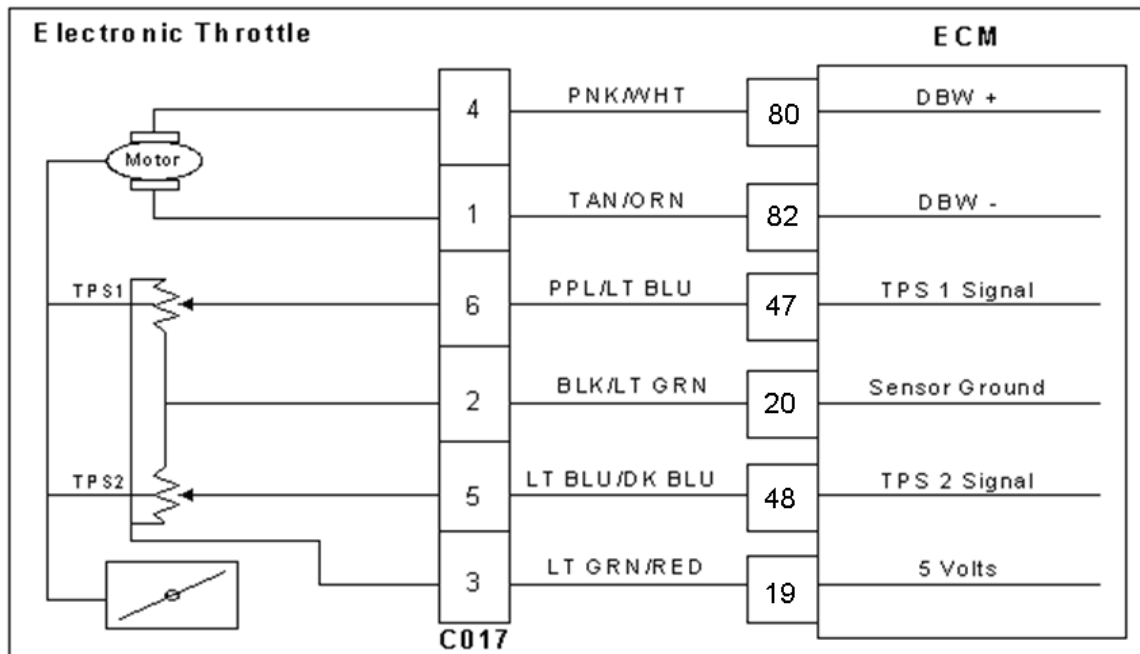

Conditions for Setting the DTC

- Throttle Position Sensor 1 & 2
- Check Condition-Key ON
- Fault Condition-TPS 1 20% lower than TPS 2
- MIL-ON for remainder of key on cycle
- Engine shutdown

Circuit description

Dual throttle Position Sensors are used within the throttle that use variable resistors to determine signal voltage based on throttle plate position. TPS 1 will read low voltage when closed and TPS 2 will read high voltage when closed. The TPS 1 and TPS 2 percentages are calculated from these voltages. Although the voltages are different, the calculated values for the throttle position percentages should be very close to the same. The TPS values are used by the ECM to determine if the throttle is opening as commanded. This fault will set if TPS 1 is 20% (or more) lower than TPS 2. At this point the throttle is considered to be out of specification, or there is a problem with the TPS signal circuit. The MIL command is on and the engine will shutdown.

DTC 121 TPS 1 Lower Than TPS 2

| Step | Action | Value(s) | Yes | No |
|------|---|----------|---|---|
| 1 | Did you perform the On-Board (OBD) System Check? | - | Go to Step (2) | Go to OBD System Check Section |
| 2 | <ul style="list-style-type: none"> • Key ON, Engine OFF • DST (Diagnostic Scan Tool) connected in System Data Mode Does the DST display more than a 20% difference between TPS 1 and TPS 2 voltage? | | Go to Step (3) | Intermittent problem Go to Intermittent section |
| 3 | <ul style="list-style-type: none"> • Key OFF • Disconnect electronic throttle connector C017 • Key ON • Change DST mode to DBW (drive by wire) test mode Is the voltage for TPS 1 less than 0.1 volts? | | Go to Step (5) | Go to Step (4) |
| 4 | <ul style="list-style-type: none"> • Key OFF • Disconnect ECM wiring harness connector C001 • Key ON • Using a DVOM check for voltage between ECM connector TPS 1 signal pin 47 and engine ground Do you have voltage? | | Repair the TPS 1 circuit shorted to voltage as necessary. Refer to Wiring Repairs in Engine Electrical. | Go to Step (9) |
| 5 | <ul style="list-style-type: none"> • Jump TPS 1 signal pin 6 to the 5 volt reference pin 3 at connector C017 Does DST display TPS 1 voltage over 4.90 volts | | Go to Step (6) | Go to Step (8) |
| 6 | <ul style="list-style-type: none"> • Inspect wire terminals at throttle connector for damage corrosion or contamination Any problems found? | | Repair the circuit as necessary. Refer to Wiring Repairs in Engine Electrical. | Go to Step (7) |
| 7 | <ul style="list-style-type: none"> • Replace the electronic Throttle Is the replacement complete? | | Go to Step (12) | - |
| 8 | <ul style="list-style-type: none"> • Key OFF • Disconnect ECM wire harness connector C001 • Using a DVOM check for continuity between throttle connector TPS 1 signal pin 6 and ECM connector TPS 1 signal pin 47 Do you have continuity between them? | | Go to Step (9) | Repair the open circuit as necessary. Refer to Wiring Repairs in Engine Electrical. |

| Step | Action | Value(s) | Yes | No |
|------|--|----------|---|---|
| 9 | <ul style="list-style-type: none"> Using a DVOM check for continuity between throttle connector signal ground pin 2 and ECM connector signal ground pin 20 Do you have continuity between them? | | Go to Step (10) | Repair the open circuit as necessary. Refer to Wiring Repairs in Engine Electrical. |
| 10 | <ul style="list-style-type: none"> Inspect ECM connector terminals for damage corrosion or contamination. Any problems found? | | Repair the circuit as necessary. Refer to Wiring Repairs in Engine Electrical | Go to Step (11) |
| 11 | <ul style="list-style-type: none"> Replace ECM Is the replacement complete? | | Go to Step (12) | - |
| 12 | <ul style="list-style-type: none"> Remove all test equipment except the DST. Connect any disconnected components, fuses, etc. Using the DST clear DTC information from the ECM. Turn the ignition OFF and wait 30 seconds. Start the engine and operate the vehicle to full operating temperature Observe the MIL Observe engine performance and drivability After operating the engine within the test parameters of DTC-121 check for any stored codes. Does the engine operate normally with no stored codes? | | System OK | Go to OBD System Check |

DTC 122-TPS 1 Low Voltage

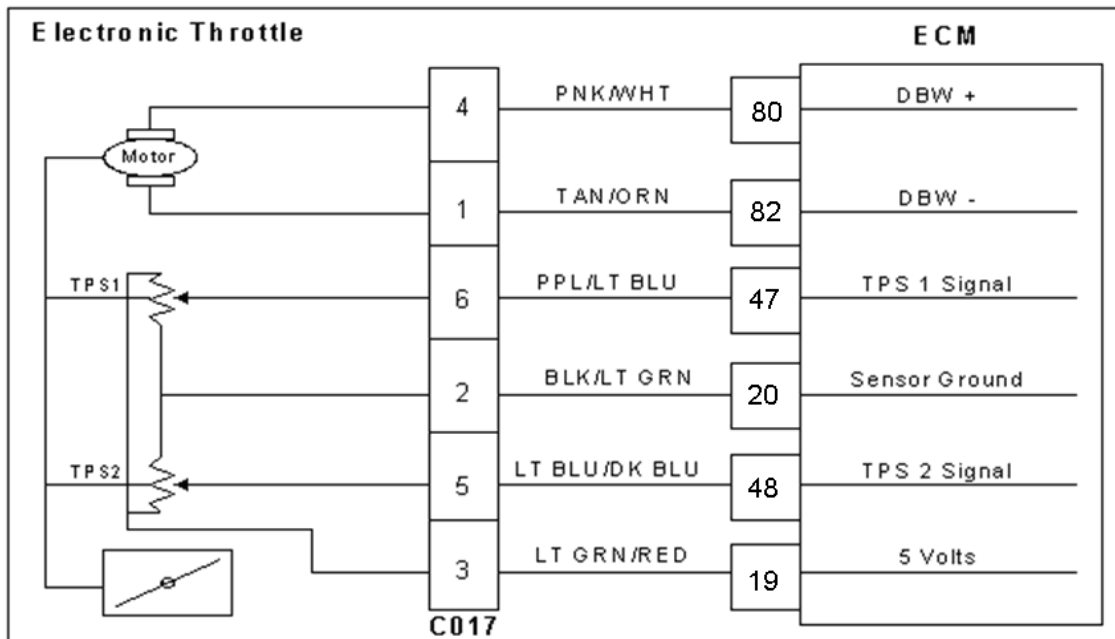

Conditions for Setting the DTC

- Throttle Position Sensor 1
- Check Condition-Cranking or Running
- Fault Condition-TPS sensor less than 0.200 volts
- MIL-ON during active fault
- Engine shutdown

Circuit Description

Dual throttle Position Sensors are used within the throttle that use variable resistors to determine signal voltage based on throttle plate position. TPS1 will read lower voltage when closed and TPS2 will read higher voltage when closed. The TPS1 and TPS2 percentages are calculated from these voltages. Although the voltages are different, the calculated values for the throttle position percentages should be very close to the same. The TPS values are used by the ECM to determine if the throttle is opening as commanded. The TPS is not serviceable and in the event of a failure the electronic throttle assembly must be replaced. This fault will set if the TPS 1 voltage is less than 0.200 volts. The MIL command is ON and the engine will shut down.

DTC 122 TPS 1 Signal Voltage Low

| Step | Action | Value(s) | Yes | No |
|------|---|----------|--|--|
| 1 | Did you perform the On-Board (OBD) System Check? | - | Go to Step (2) | Go to OBD System Check Section |
| 2 | <ul style="list-style-type: none"> • Key ON, Engine OFF • DST (Diagnostic Scan Tool) connected in DBW (Drive by Wire) throttle test mode Does the DST display TPS 1 voltage of 0.200 volts or less with the throttle closed? | | Go to Step (4) | Go to Step (3) |
| 3 | <ul style="list-style-type: none"> • Slowly depress Foot Pedal while observing TPS 1 voltage Does TPS 1 voltage ever fall below 0.200 volts? | | Go to Step (4) | Intermittent problem Go to Intermittent section |
| 4 | <ul style="list-style-type: none"> • Key OFF • Disconnect the electronic throttle connector C017 • Jump the 5 volt reference circuit pin 3 and TPS 1 signal circuit pin 6 together at the throttle connector • Key ON Does DST display TPS 1 voltage of 4.0 volts or greater? | | Go to Step (7) | Go to Step (5) |
| 5 | <ul style="list-style-type: none"> • Key OFF • Disconnect ECM wire harness connector C001 • Using a DVOM check continuity between the electronic throttle connector signal pin 6 and ECM connector TPS 1 signal pin 47 Do have continuity between them? | | Go to Step (6) | Repair the circuit as necessary. Refer to Wiring Repairs in Engine Electrical. |
| 6 | <ul style="list-style-type: none"> • Replace ECM Is the replacement complete? | | Go to Step (9) | - |
| 7 | <ul style="list-style-type: none"> • Inspect the throttle wire harness connector terminals for damage, corrosion or contamination Did you find a problem? | | Repair the circuit as necessary. Refer to Wiring Repairs in Engine Electrical. | Go to Step (8) |
| 8 | <ul style="list-style-type: none"> • Replace the electronic throttle Is the replacement complete? | | Go to Step (9) | - |

| Step | Action | Value(s) | Yes | No |
|------|---|----------|-----------|------------------------|
| 9 | <ul style="list-style-type: none"> • Remove all test equipment except the DST. • Connect any disconnected components, fuses, etc. • Using the DST clear DTC information from the ECM. • Turn the ignition OFF and wait 30 seconds. • Start the engine and operate the vehicle to full operating temperature • Observe the MIL • Observe engine performance and drivability • After operating the engine within the test parameters of DTC-122 check for any stored codes. <p>Does the engine operate normally with no stored codes?</p> | | System OK | Go to OBD System Check |

DTC 123-TPS 1 High Voltage

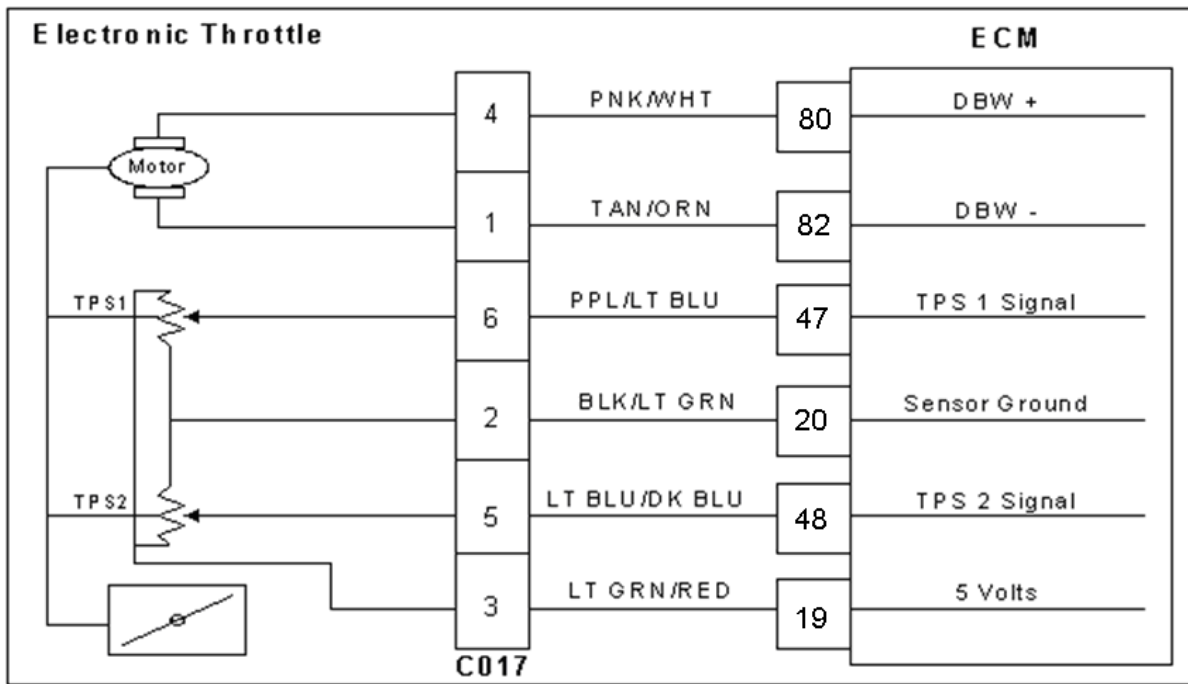

Conditions for Setting the DTC

- Throttle Position Sensor 1
- Check Condition-Cranking or Running
- Fault Condition-TPS sensor voltage exceeds 4.800 volts
- MIL-ON during active fault
- Engine shutdown

Circuit Description

Dual throttle Position Sensors are used within the throttle that use variable resistors to determine signal voltage based on throttle plate position. TPS1 will read lower voltage when closed and TPS2 will read higher voltage when closed. The TPS1 and TPS2 percentages are calculated from these voltages. Although the voltages are different, the calculated values for the throttle position percentages should be very close to the same. The TPS values are used by the ECM to determine if the throttle is opening as commanded. The TPS is not serviceable and in the event of a failure the electronic throttle assembly must be replaced. This fault will set if the TPS 1 voltage exceeds 4.800 volts. The MIL command is ON and the engine will shut down.

DTC 123 TPS 1 Signal Voltage High

| Step | Action | Value(s) | Yes | No |
|------|---|----------|--|--|
| 1 | Did you perform the On-Board (OBD) System Check? | - | Go to Step (2) | Go to OBD System Check Section |
| 2 | <ul style="list-style-type: none"> • Key ON, Engine OFF • DST (Diagnostic Scan Tool) connected Does the DST display TPS 1 voltage of 4.800 volts or greater with the throttle closed? | | Go to Step (4) | Go to Step (3) |
| 3 | <ul style="list-style-type: none"> • Slowly depress Foot Pedal while observing TPS 1 voltage Does TPS 1 voltage ever exceed 4.800 volts? | | Go to Step (4) | Intermittent problem Go to Intermittent section |
| 4 | <ul style="list-style-type: none"> • Key OFF • Disconnect electronic throttle connector • Key ON Does DST display TPS 1 voltage less than 0.2 volts? | | Go to Step (7) | Go to Step (5) |
| 5 | <ul style="list-style-type: none"> • Key OFF • Disconnect ECM wire harness connector C001 • Key ON • Using a DVOM check for voltage between TPS 1 signal at the ECM connector pin 47 and engine ground Do you have voltage? | | Repair the circuit as necessary. Refer to Wiring Repairs in Engine Electrical. | Go to Step (6) |
| 6 | <ul style="list-style-type: none"> • Replace ECM Is the replacement complete? | | Go to Step (11) | - |
| 7 | <ul style="list-style-type: none"> • Back probe sensor ground circuit at the ECM side of the wire harness pin 20 with a test light connected to battery voltage Does the test light come on? | | Go to Step (8) | Go to Step (10) |
| 8 | <ul style="list-style-type: none"> • Inspect the electronic throttle connector terminals for damage, corrosion or contamination Did you find a problem? | | Repair the circuit as necessary. Refer to Wiring Repairs in Engine Electrical. | Go to Step (9) |
| 9 | <ul style="list-style-type: none"> • Replace the electronic throttle Is the replacement complete? | | Go to Step (11) | - |
| 10 | <ul style="list-style-type: none"> • Key OFF • Disconnect ECM connector C001 • Using a DVOM check for continuity between the electronic throttle connector sensor ground pin 2 and ECM connector TPS 1 sensor ground pin 47 Do have continuity between them? | | Go to Step (6) | Repair the circuit as necessary. Refer to Wiring Repairs in Engine Electrical. |

| Step | Action | Value(s) | Yes | No |
|------|---|----------|-----------|------------------------|
| 11 | <ul style="list-style-type: none"> • Remove all test equipment except the DST. • Connect any disconnected components, fuses, etc. • Using the DST clear DTC information from the ECM. • Turn the ignition OFF and wait 30 seconds. • Start the engine and operate the vehicle to full operating temperature • Observe the MIL • Observe engine performance and drivability • After operating the engine within the test parameters of DTC-123 check for any stored codes. <p>Does the engine operate normally with no stored codes?</p> | | System OK | Go to OBD System Check |

DTC 127-IAT Higher Than Expected 2

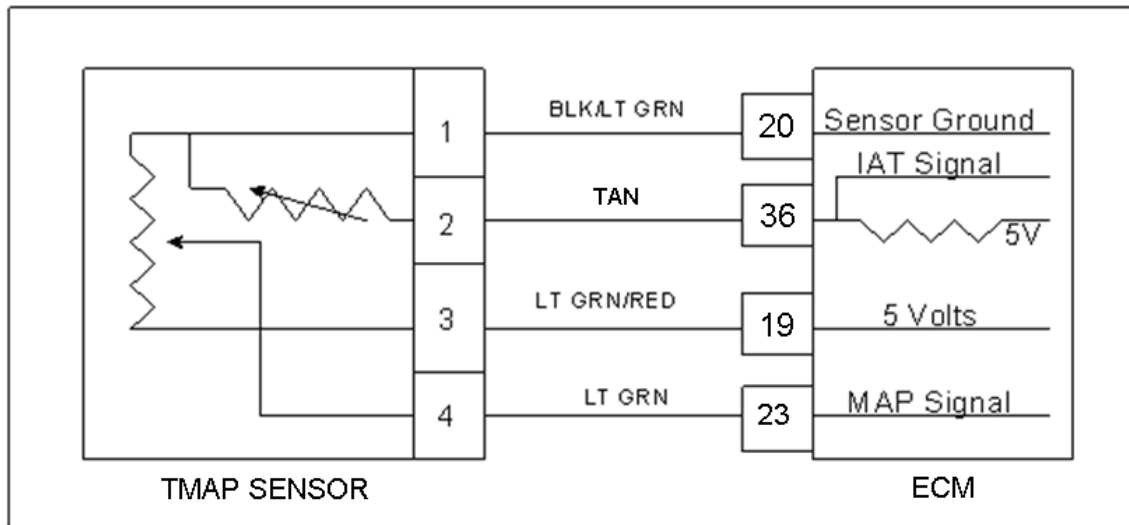

Conditions for Setting the DTC

- Intake Air Temperature
- Check Condition-Engine Running
- Fault Condition-Intake Air Temperature greater than 155 degrees F. with engine speed greater than 1200 rpm
- Fault condition must be active for longer than 10 seconds
- MIL-ON for active fault
- Engine Shut Down

Circuit Description

The TMAP is a combined IAT (Intake Air Temperature) and MAP (Manifold Absolute Pressure) sensor. A temperature sensitive resistor is used in the TMAP located in the intake manifold of the engine. It is used to monitor incoming air temperature, and the output in conjunction with other sensors is used to determine the airflow to the engine. The ECM provides a voltage divider circuit so that when the air is cool, the signal reads a higher voltage, and lower when warm. This fault will set if the intake air temperature is greater than 155 degrees F. with engine speed greater than 1200 rpm. The MIL light command is on during this active fault and the engine will shut down.

DTC 127-IAT Higher Than Expected 2

Diagnostic Aid

- This fault will set when inlet air is much hotter than normal. The most common cause of high inlet air temperature is a problem with the inlet air system. Ensure that the air inlet is not obstructed, modified or damaged.
- Inspect the air inlet system for cracks or breaks that may allow unwanted under hood air in to the air inlet system
- If none of the above can be found, follow the diagnostic steps for DTC 112-IAT Low Voltage.

DTC 129-BP Low Pressure

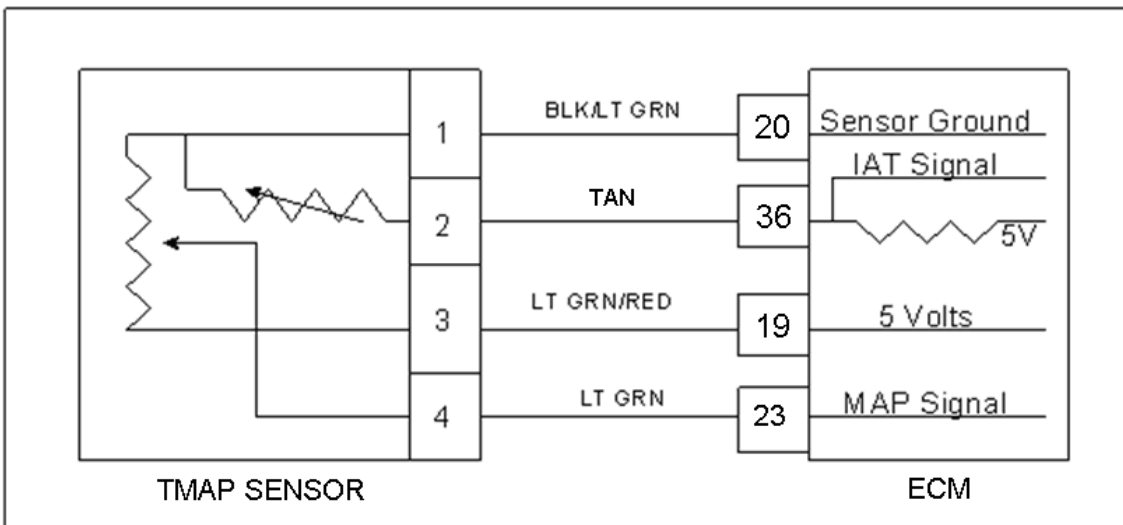

Conditions for Setting the DTC

- Barometric Pressure
- Check Condition-Key ON
- Fault Condition-BP less than 8.30 PSia
- MIL-ON for active fault
- Adaptive-Disabled

Circuit Description

The BP (Barometric Pressure) is estimated from the TMAP sensor. The barometric pressure value is used for fuel and airflow calculations. This fault sets in the event the BP value is out of the normal range.

DTC 129-BP Low Pressure

| Step | Action | Value(s) | Yes | No |
|------|---|----------|--|--|
| 1 | Did you perform the On-Board (OBD) System Check? | - | Go to Step (2) | Go to OBD System Check Section |
| 2 | <ul style="list-style-type: none"> • Key ON. • DST (Diagnostic Scan Tool) connected in System Data Mode Does DST display BP pressure of 8.30 PSIA or less? | | Go to Step (3) | Intermittent problem. Go to Intermittent section |
| 3 | <ul style="list-style-type: none"> • Key OFF • Disconnect the TMAP sensor connector • Jump the 5 volt reference pin 3 and MAP signal pin 4 together • Key ON Does the DST display BP pressure of 16.00 PSIA or greater? | | Go to Step (4) | Go to Step (8) |
| 4 | <ul style="list-style-type: none"> • Inspect TMAP connector and wire harness connector terminals for corrosion, contamination or mechanical damage Any problems found? | | Repair the circuit as necessary. Refer to Wiring Repairs in Engine Electrical. | Go to Step (5) |
| 5 | <ul style="list-style-type: none"> • Key OFF • Disconnect ECM connector C001 • Check for continuity between TMAP sensor connector pin 4 and ECM connector pin 23 Do you have continuity between them? | | Go to Step (6) | Repair the circuit as necessary. Refer to Wiring Repairs in Engine Electrical. |
| 6 | <ul style="list-style-type: none"> • Check for continuity between TMAP sensor connector 5 volt supply pin 3 and ECM connector pin 19 Do you have continuity between them? | | Go to Step (7) | Repair the circuit as necessary. Refer to Wiring Repairs in Engine Electrical. |
| 7 | <ul style="list-style-type: none"> • Check for continuity between TMAP sensor connector ground pin 1 and ECM connector pin 20 Do you have continuity between them? | | Go to Step (17) | Repair the circuit as necessary. Refer to Wiring Repairs in Engine Electrical. |

| Step | Action | Value(s) | Yes | No |
|------|---|----------|--|--|
| 8 | <ul style="list-style-type: none"> Remove the Jumper that was installed during step 3 Probe TMAP connector signal circuit pin 4 with a test light connected to battery voltage Does the DST display BP pressure of 16.00 PSIa or greater? | | Go to Step (9) | Go to Step (13) |
| 9 | <ul style="list-style-type: none"> Key OFF Disconnect ECM connector C001 Check for continuity between TMAP sensor connector pin 3 and ECM connector pin 19 Do you have continuity between them? | | Go to Step (10) | Repair the circuit as necessary. Refer to Wiring Repairs in Engine Electrical. |
| 10 | <ul style="list-style-type: none"> Check for continuity between TMAP sensor connector 5 volt reference pin 3 and engine ground Do you have continuity? | | Repair the open ground circuit as necessary. Refer to Wiring Repairs in Engine Electrical. | Go to Step (11) |
| 11 | <ul style="list-style-type: none"> Inspect TMAP and ECM connector pins for corrosion, contamination or mechanical damage Any problems found? | | Repair the circuit as necessary. Refer to Wiring Repairs in Engine Electrical. | Go to Step (16) |
| 12 | <ul style="list-style-type: none"> Replace ECM. Refer to ECM replacement in the Engine Controls Section. Is the replacement complete? | | Go to Step(17) | - |
| 13 | <ul style="list-style-type: none"> Disconnect ECM connector C001 Check for continuity between TMAP sensor connector pin 4 and ECM pin 23 Do you have continuity between them? | | Go to Step (14) | Repair the circuit as necessary. Refer to Wiring Repairs in Engine Electrical. |
| 14 | <ul style="list-style-type: none"> Check for continuity between TMAP sensor connector pin 4 and engine ground Do you have continuity? | | Repair the open ground circuit as necessary. Refer to Wiring Repairs in Engine Electrical. | Go to Step (15) |

| Step | Action | Value(s) | Yes | No |
|------|--|----------|--|------------------------|
| 15 | <ul style="list-style-type: none"> Inspect ECM connector and wire harness connector pins for corrosion, contamination or mechanical damage Any problems found? | | Repair the circuit as necessary. Refer to Wiring Repairs in Engine Electrical. | Go to Step (16) |
| 16 | <ul style="list-style-type: none"> Replace ECM. Refer to ECM replacement in the Engine Controls Section. Is the replacement complete? | | Go to Step (18) | - |
| 17 | <ul style="list-style-type: none"> Replace TMAP sensor Is the replacement complete? | | Go to Step (18) | - |
| 18 | <ul style="list-style-type: none"> Remove all test equipment except the DST. Connect any disconnected components, fuses, etc. Using the DST clear DTC information from the ECM. Turn the ignition OFF and wait 30 seconds. Start the engine and operate the vehicle to full operating temperature Observe the MIL Observe engine performance and drivability After operating the engine within the test parameters of DTC-129 check for any stored codes. Does the engine operate normally with no stored codes? | | System OK | Go to OBD System Check |

DTC 134-EGO 1 Pre Cat Open/Lazy

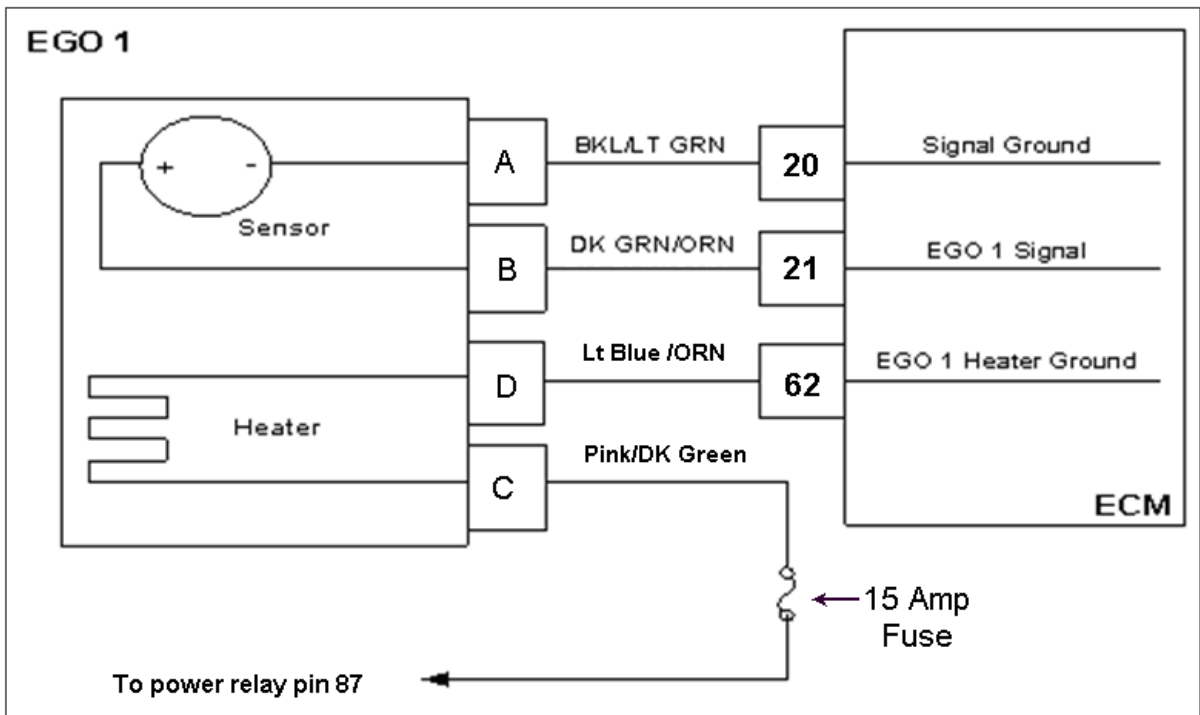

Conditions for Setting the DTC

- Heated Oxygen Sensor
- Check condition-Engine running
- Fault condition-EGO 1 pre catalyst persistently cold for more than 120 seconds
- MIL-ON during active fault
- Adaptive-Disabled during active fault
- Closed Loop-Disabled during active fault

Circuit Description

The EGO 1 sensor is used to determine if the fuel flow to the engine is correct by measuring the oxygen content in the exhaust gas. The ECM uses this information to correct the fuel flow with the Closed Loop multiplier and the Adaptive multiplier. This fault will set if EGO 1 is cold, non-responsive, or inactive for more than 120 seconds.

DTC 134-EGO 1 Open/Inactive

| Step | Action | Value(s) | Yes | No |
|------|---|----------------|--|--|
| 1 | Did you perform the On-Board (OBD) System Check? | - | Go to Step (2) | Go to OBD System Check Section |
| 2 | <ul style="list-style-type: none"> • Key ON, Engine Running • DST (Diagnostic Scan Tool) connected in System Data Mode • Run engine to full operating temperature and then idle for a minimum of 2 minutes Does DST display EGO 1 voltage fixed between 0.4 and 0.5 volts after at least 2 minutes of idle run time? | | Go to Step (3) | Intermittent problem. See Electrical Section Intermittent Electrical Diagnosis |
| 3 | <ul style="list-style-type: none"> • Key OFF • Disconnect EGO 1 connector C005 • Key ON • Using a DVOM check for voltage between EGO 1 connector pins C and D (Check must be made within 30 seconds or before power relay shuts down) Do you have voltage? | | Go to Step (8) | Go To Step (4) |
| 4 | <ul style="list-style-type: none"> • Key OFF • Using a DVOM check for voltage between EGO 1 connector pin C and engine ground • Key ON (Check must be made within 30 seconds or before power relay shuts down) Do you have voltage? | System Voltage | Go to Step (5) | Repair system power relay open circuit |
| 5 | <ul style="list-style-type: none"> • Disconnect ECM connector C001 • Using a DVOM check for continuity between EGO 1 connector pin D and ECM connector pin 62 Do you have continuity? | | Go to Step (6) | Repair open heater ground circuit |
| 6 | <ul style="list-style-type: none"> • Inspect wire harness connector C005 pins B and D and C001 pins 21 and 62 for damage, corrosion or contamination Did You find a problem? | | Correct the problem as required see Electrical Section wire harness repair | Go to Step (7) |
| 7 | <ul style="list-style-type: none"> • Replace ECM Is the replacement complete? | | Go to Step (11) | - |

| Step | Action | Value(s) | Yes | No |
|------|--|----------|-----------------|---------------------------------|
| 8 | <ul style="list-style-type: none"> • Key OFF • Disconnect ECM wire harness connector C001 • Using a DVOM check for continuity between EGO 1 pin B and ECM connector pin 21 Do you have continuity? | | Go to Step (9) | Repair open EGO 1 circuit |
| 9 | <ul style="list-style-type: none"> • Using a DVOM check for continuity between EGO 1 pin A and ECM connector pin 20 Do you have continuity? | | Go to Step (10) | Repair open EGO 1 signal ground |
| 10 | <ul style="list-style-type: none"> • Replace EGO 1 sensor Is the replacement complete? | | Go to Step (11) | - |
| 11 | <ul style="list-style-type: none"> • Remove all test equipment except the DST. • Connect any disconnected components, fuses, etc. • Using the DST clear DTC information from the ECM. • Turn the ignition OFF and wait 30 seconds. • Start the engine and operate the vehicle to full operating temperature • Observe the MIL • Observe engine performance and drivability • After operating the engine within the test parameters of DTC-134 check for any stored codes. Does the engine operate normally with no stored codes? | | System OK | Go to OBD System Check |

DTC 217-ECT Higher Than Expected 2

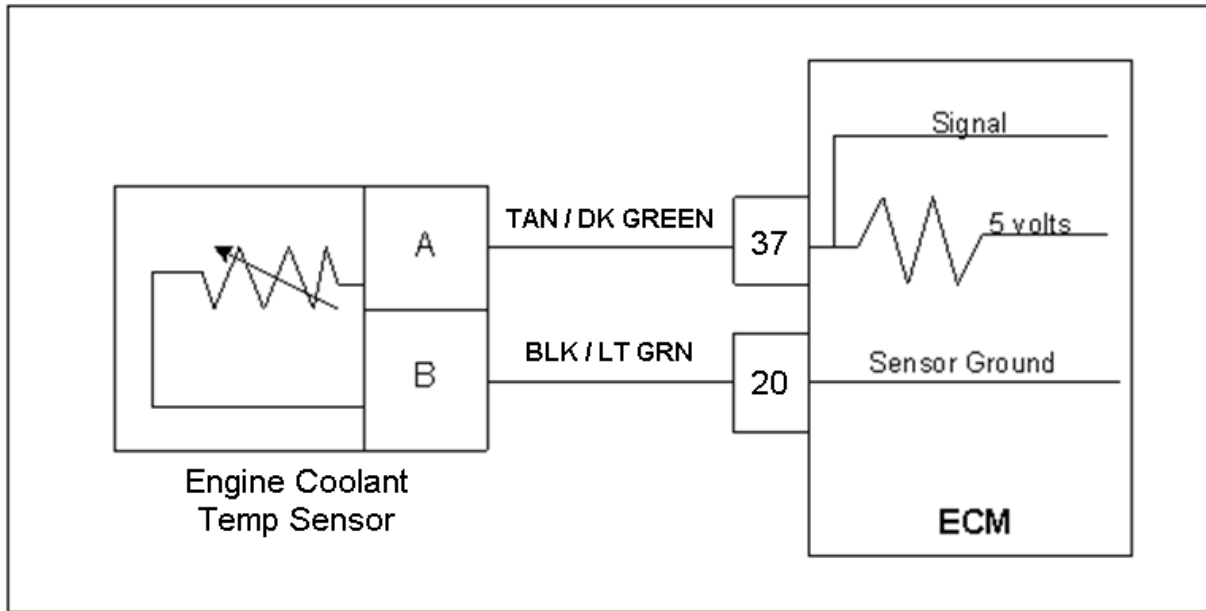

Conditions for Setting the DTC

- Engine Coolant Temperature
- Check Condition-Engine Running
- Fault Condition-Engine Coolant Temperature reading or estimate greater than 230 degrees F. for greater than 15 seconds
- MIL-On
- Engine shutdown will occur

Circuit Description

The ECT (Engine Coolant Temperature) sensor is a temperature sensitive resistor located in the engine coolant sensor that is located in the coolant passage. The ECT is used for engine airflow calculation, fuel enrichment, and ignition timing control and to enable certain other temperature dependant operations. This code set is designed to help prevent engine damage from overheating. The ECM provides a voltage divider circuit so when the sensor reading is cool the sensor reads higher voltage, and lower when warm. This fault will set when the coolant exceeds 230 degrees F. for more than 15 seconds. Engine shutdown will occur if this code occurs.

DTC 217-ECT Higher Than Expected 2

| STEP | Action | Value(s) | Yes | No |
|------|--|----------|------------------------|--|
| 1 | Did you perform the On-Board (OBD) System Check? | - | Go to Step (2) | Go to OBD System Check Section |
| 2 | <ul style="list-style-type: none"> • Key ON • DST (Diagnostic Scan Tool) connected in system data mode <p>Warm engine to normal operating temperature, then run the engine above 1200 rpm for at least 60 seconds</p> <p>Does the DST display ECT temperature of 230 degrees F or greater?</p> | | Go to Step (3) | Intermittent problem Go to Intermittent section |
| 3 | <p>Verify with a temperature gauge that the engine coolant is over 230 degrees F.</p> <p>Does the temperature gauge indicated 230 degrees F. or greater?</p> | | Repair cooling system. | Go to step (4) |
| 4 | Verify ECT Circuit function. | | - | - |

DTC 219-Max Govern Speed Override

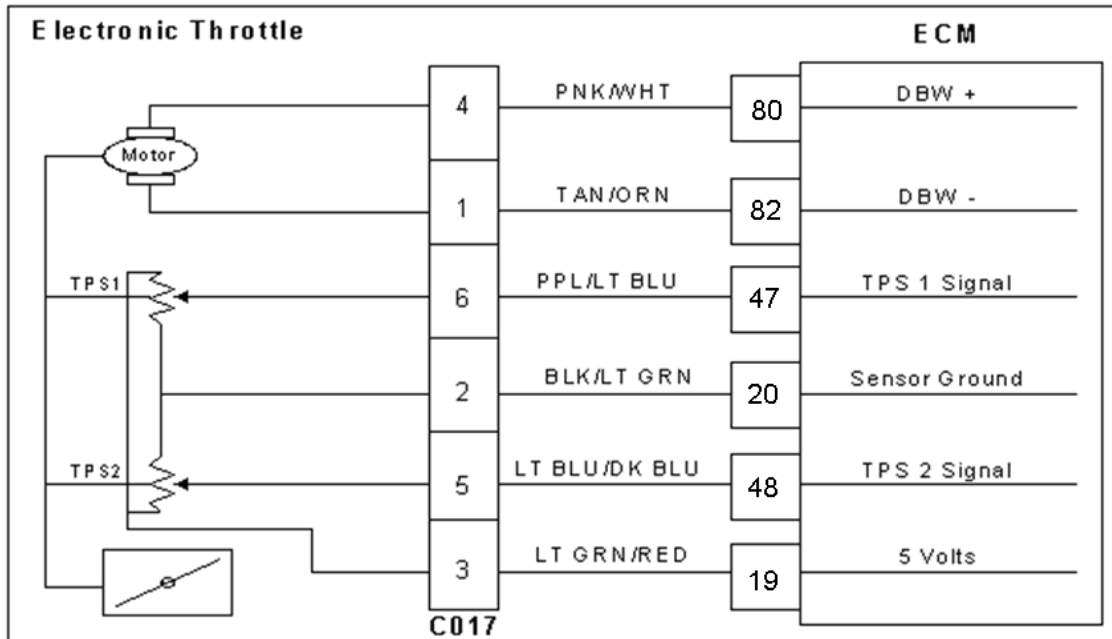

Conditions for Setting the DTC

- Max Govern Speed Override
- Check Condition-Engine Running
- Fault Condition-Engine rpm greater than 2,250 rpm
- Fault condition active for 2 or more seconds
- MIL-ON during active fault

Circuit description

This fault will set anytime the engine rpm exceeds 2,250 rpm for longer than 2 seconds. The MIL command is ON during this active fault

Diagnostic Aid

Check for other stored DTC codes before using the following DTC chart for this code set. Always diagnose and repair any existing codes starting with the lowest numerical code first.

DTC 219-Max Govern Speed Override

| Step | Action | Value(s) | Yes | No |
|------|--|----------|----------------|--------------------------------|
| 1 | Did you perform the On-Board (OBD) System Check? | - | Go to Step (2) | Go to OBD System Check Section |
| 2 | <ul style="list-style-type: none"> • Key ON, Engine OFF • DST connected Are any other DTC codes present with DTC 219? | | Go to Step (3) | Go to Step (4) |
| 3 | <ul style="list-style-type: none"> • Diagnose and repair any other DTC codes stored before proceeding with this chart. Have any other DTC codes been diagnosed and repaired? | | Go to Step (4) | - |
| 4 | <ul style="list-style-type: none"> • Check the service part number on the ECM to ensure the correct calibration is in use Is the Service Part Number Correct? | | Go to Step (6) | Go to Step 5 |
| 5 | <ul style="list-style-type: none"> • Replace ECM with correct service part number Is the replacement complete? | | Go to Step (9) | - |
| 6 | <ul style="list-style-type: none"> • Check the mechanical operation of the throttle Is the mechanical operation of the throttle OK? | | Go to Step (8) | Go to Step (7) |
| 7 | <ul style="list-style-type: none"> • Correct mechanical operation of the throttle. Refer to Engine & Component section Has the mechanical operation of the throttle been corrected? | | Go to Step (9) | - |
| 8 | <ul style="list-style-type: none"> • Check engine for large manifold vacuum leaks. Refer to Symptom Diagnostic section Did you find and correct the vacuum leak? | | Go to Step (9) | Go to OBD System Check Section |
| 9 | <ul style="list-style-type: none"> • Remove all test equipment except the DST. • Connect any disconnected components, fuses, etc. • Using the DST clear DTC information from the ECM. • Turn the ignition OFF and wait 30 seconds. • Start the engine and operate the vehicle to full operating temperature • Observe the MIL • Observe engine performance and drivability • After operating the engine within the test parameters of DTC-219 check for any stored codes. Does the engine operate normally with no stored codes? | | System OK | Go to OBD System Check |

DTC 221-TPS 1 Higher Than TPS 2

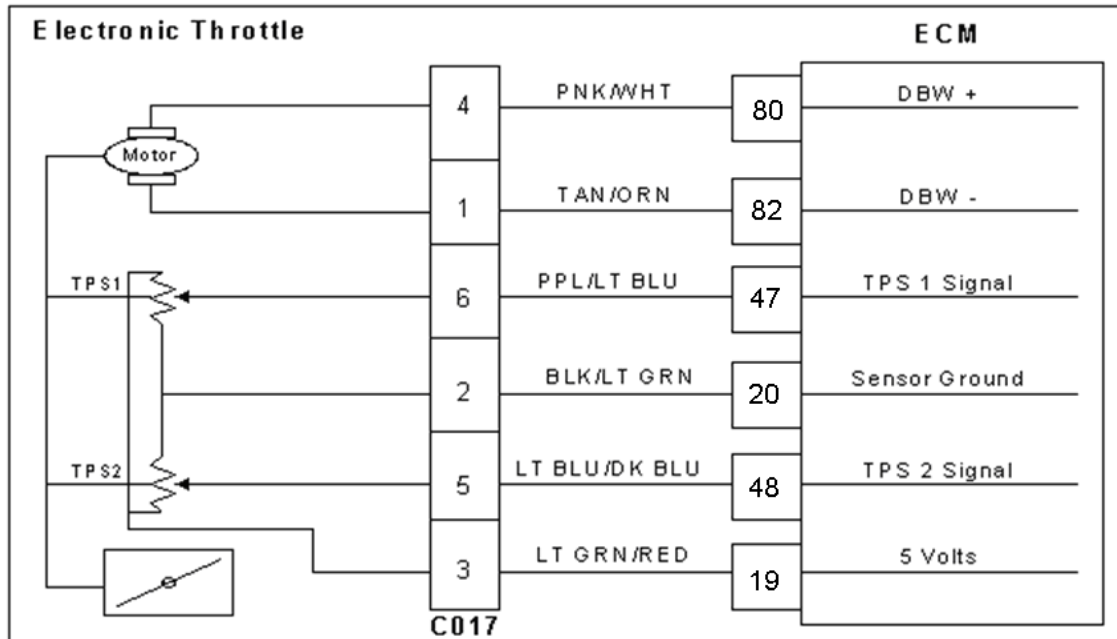

Conditions for Setting the DTC

- Throttle Position Sensor 1 & 2
- Check Condition-Key ON
- Fault Condition-TPS 1 20% higher than TPS2
- MIL-ON for remainder of key on cycle
- Engine shutdown

Circuit Description

Dual throttle Position Sensors are used within the throttle that use variable resistors to determine signal voltage based on throttle plate position. TPS 1 will read lower voltage when closed and TPS 2 will read higher voltage when closed. The TPS 1 and TPS 2 percentages are calculated from these voltages. Although the voltages are different, the calculated values for the throttle position percentages should be very close to the same. The TPS values are used by the ECM to determine if the throttle is opening as commanded. The TPS is not serviceable and in the event of a failure the electronic throttle assembly must be replaced. This fault will set if TPS 1 is 20% (or more) higher than TPS 2. At this point the throttle is considered to be out of specification, or there is a problem with the TPS signal circuit. The MIL command is ON and the engine will shutdown.

DTC 221 TPS 1 Higher Than TPS 2

| Step | Action | Value(s) | Yes | No |
|------|---|----------|---|---|
| 1 | Did you perform the On-Board (OBD) System Check? | - | Go to Step (2) | Go to OBD System Check Section |
| 2 | <ul style="list-style-type: none"> • Key ON, Engine OFF • DST (Diagnostic Scan Tool) connected in System Data Mode Does the DST display more than a 20% difference between TPS 1 and TPS 2? | | Go to Step (3) | Intermittent problem Go to Intermittent section |
| 3 | <ul style="list-style-type: none"> • Key OFF • Disconnect electronic throttle connector C017 • Key ON • Change DST mode to DBW (drive by wire) test mode Is the voltage for TPS 1 less than 0.1 volts? | | Go to Step (5) | Go to Step (4) |
| 4 | <ul style="list-style-type: none"> • Key OFF • Disconnect ECM wiring harness connector C001 • Key ON • Using a DVOM check for voltage between ECM connector TPS 1 signal pin 5 and engine ground Do you have voltage? | | Repair the TPS 1 circuit shorted to voltage as necessary. Refer to Wiring Repairs in Engine Electrical. | Go to Step (9) |
| 5 | <ul style="list-style-type: none"> • Jump TPS 1 signal pin 6 to the 5 volt reference pin 3 at connector C017 Does DST display TPS 1 voltage over 4.900 volts? | | Go to Step (6) | Go to Step (8) |
| 6 | <ul style="list-style-type: none"> • Inspect wire terminals at throttle connector for damage corrosion or contamination Any problems found? | | Repair the circuit as necessary. Refer to Wiring Repairs in Engine Electrical. | Go to Step (7) |
| 7 | <ul style="list-style-type: none"> • Replace the electronic Throttle Is the replacement complete? | | Go to Step (12) | - |
| 8 | <ul style="list-style-type: none"> • Key OFF • Disconnect ECM wire harness connector C001 • Using a DVOM check for continuity between throttle connector TPS 1 signal pin 6 and ECM connector TPS 1 signal pin 47 Do you have continuity between them? | | Go to Step (9) | Repair the open circuit as necessary. Refer to Wiring Repairs in Engine Electrical. |

| Step | Action | Value(s) | Yes | No |
|------|--|----------|---|---|
| 9 | <ul style="list-style-type: none"> Using a DVOM check for continuity between throttle connector signal ground pin 2 and ECM connector signal ground pin 20 Do you have continuity between them? | | Go to Step (10) | Repair the open circuit as necessary. Refer to Wiring Repairs in Engine Electrical. |
| 10 | <ul style="list-style-type: none"> Inspect ECM connector terminals for damage corrosion or contamination. Any problems found? | | Repair the circuit as necessary. Refer to Wiring Repairs in Engine Electrical | Go to Step (11) |
| 11 | <ul style="list-style-type: none"> Replace ECM Is the replacement complete? | | Go to Step (12) | - |
| 12 | <ul style="list-style-type: none"> Remove all test equipment except the DST. Connect any disconnected components, fuses, etc. Using the DST clear DTC information from the ECM. Turn the ignition OFF and wait 30 seconds. Start the engine and operate the vehicle to full operating temperature Observe the MIL Observe engine performance and drivability After operating the engine within the test parameters of DTC-221 check for any stored codes. Does the engine operate normally with no stored codes? | | System OK | Go to OBD System Check |

DTC 222-TPS 2 Signal Voltage Low

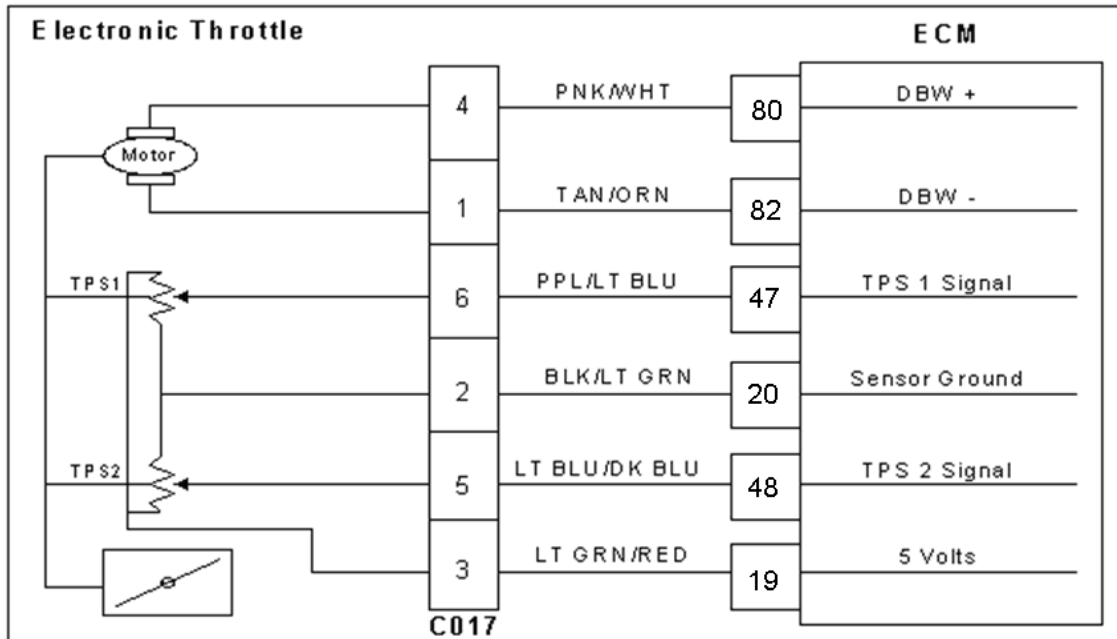

Conditions for Setting the DTC

- Throttle Position Sensor 2
- Check Condition-Cranking or Running
- Fault Condition-TPS 2 sensor voltage less than 0.200 volts
- MIL-ON during active fault

Circuit Description

Dual throttle Position Sensors are used within the throttle that use variable resistors to determine signal voltage based on throttle plate position. TPS1 will read lower voltage when closed and TPS2 will read higher voltage when closed. The TPS1 and TPS2 percentages are calculated from these voltages. Although the voltages are different, the calculated values for the throttle position percentages should be very close to the same. The TPS values are used by the ECM to determine if the throttle is opening as commanded. The TPS is not serviceable and in the event of a failure the electronic throttle assembly must be replaced. This fault will set if the TPS 2 voltage is less than 0.200 volts. The MIL command is ON.

DTC 222 TPS 2 Signal Voltage Low

| Step | Action | Value(s) | Yes | No |
|------|---|----------|--|--|
| 1 | Did you perform the On-Board (OBD) System Check? | - | Go to Step (2) | Go to OBD System Check Section |
| 2 | <ul style="list-style-type: none"> • Key ON, Engine OFF • DST (Diagnostic Scan Tool) connected in DBW (Drive by Wire) throttle test mode Does the DST display TPS 2 voltage of 0.200 volts or less with the throttle closed? | | Go to Step (4) | Go to Step (3) |
| 3 | <ul style="list-style-type: none"> • Slowly depress Foot Pedal while observing TPS 2 voltage Does TPS 2 voltage ever fall below 0.200 volts? | | Go to Step (4) | Intermittent problem Go to Intermittent section |
| 4 | <ul style="list-style-type: none"> • Key OFF • Disconnect electronic throttle connector C017 • Jumper the 5 volt reference circuit pin 3 and TPS 2 signal circuit pin 5 together at the throttle connector • Key ON Does DST display TPS 2 voltage of 4.0 volts or greater? | | Go to Step (7) | Go to Step (5) |
| 5 | <ul style="list-style-type: none"> • Key OFF • Disconnect ECM wire harness connector C001 • Using a DVOM check continuity between TPS 2 connector signal pin 5 and ECM connector TPS 2 Signal pin 48 Do have continuity between them? | | Go to Step (6) | Repair the circuit as necessary. Refer to Wiring Repairs in Engine Electrical. |
| 6 | <ul style="list-style-type: none"> • Replace ECM Is the replacement complete? | | Go to Step (9) | - |
| 7 | <ul style="list-style-type: none"> • Inspect the electronic throttle wire harness connector terminals for damage, corrosion or contamination Did you find a problem? | | Repair the circuit as necessary. Refer to Wiring Repairs in Engine Electrical. | Go to Step (8) |
| 8 | <ul style="list-style-type: none"> • Replace the electronic throttle Is the replacement complete? | | Go to Step (9) | - |

| Step | Action | Value(s) | Yes | No |
|------|---|----------|-----------|------------------------|
| 9 | <ul style="list-style-type: none"> • Remove all test equipment except the DST. • Connect any disconnected components, fuses, etc. • Using the DST clear DTC information from the ECM. • Turn the ignition OFF and wait 30 seconds. • Start the engine and operate the vehicle to full operating temperature • Observe the MIL • Observe engine performance and drivability • After operating the engine within the test parameters of DTC-222 check for any stored codes. <p>Does the engine operate normally with no stored codes?</p> | | System OK | Go to OBD System Check |

DTC 223-TPS 2 Signal Voltage High

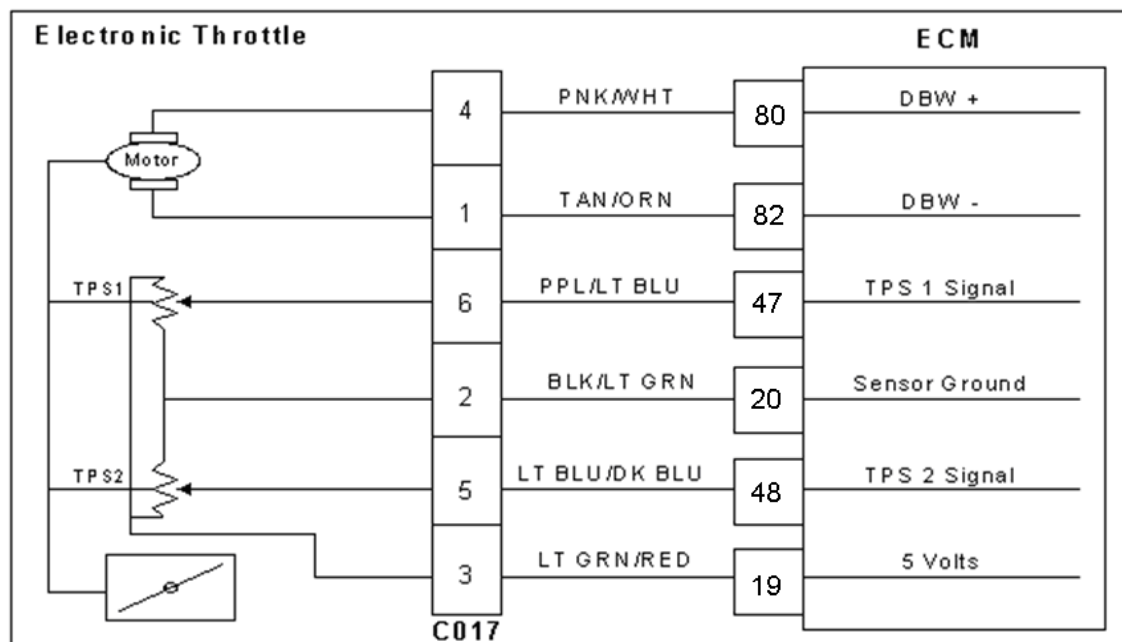

Conditions for Setting the DTC

- Throttle Position Sensor 2
- Check Condition-Cranking or Running
- Fault Condition-TPS 2 sensor exceeds 4.800 volts
- MIL-ON during active fault

Circuit Description

Dual throttle Position Sensors are used within the throttle that uses variable resistors to determine signal voltage based on throttle plate position. TPS1 will read lower voltage when closed and TPS2 will read higher voltage when closed. The TPS1 and TPS2 percentages are calculated from these voltages. Although the voltages are different, the calculated values for the throttle position percentages should be very close to the same. The TPS values are used by the ECM to determine if the throttle is opening as commanded. The TPS is not serviceable and in the event of a failure the electronic throttle assembly must be replaced. This fault will set if the TPS 2 voltage is greater than 4.800 volts. The MIL command is ON.

DTC 223 TPS 2 Signal Voltage High

| Step | Action | Value(s) | Yes | No |
|------|---|----------|--|--|
| 1 | Did you perform the On-Board (OBD) System Check? | - | Go to Step (2) | Go to OBD System Check Section |
| 2 | <ul style="list-style-type: none"> • Key ON, Engine OFF • DST (Diagnostic Scan Tool) connected in DBW (Drive by Wire) throttle test mode Does the DST display TPS 2 voltage of 4.800 volts or greater with the throttle closed? | | Go to Step (4) | Go to Step (3) |
| 3 | <ul style="list-style-type: none"> • Slowly depress Foot Pedal while observing TPS 2 voltage Does TPS 2 voltage ever exceed 4.800 volts? | | Go to Step (4) | Intermittent problem Go to Intermittent section |
| 4 | <ul style="list-style-type: none"> • Key OFF • Disconnect electronic throttle connector C017 • Key ON Does DST display TPS 2 voltage less than 0.2 volts? | | Go to Step (7) | Go to Step (5) |
| 5 | <ul style="list-style-type: none"> • Key OFF • Disconnect ECM wire harness connector C001 • Key ON • Using a DVOM check for voltage between electronic throttle connector TPS 2 signal pin 5 and engine ground Do you have voltage? | | Repair the circuit as necessary. Refer to Wiring Repairs in Engine Electrical. | Go to Step (6) |
| 6 | <ul style="list-style-type: none"> • Replace ECM Is the replacement complete? | | Go to Step (11) | - |
| 7 | <ul style="list-style-type: none"> • Probe sensor ground circuit at the ECM side of the wire harness pin 3 with a test light connected to battery voltage Does the test light come on? | | Go to Step (8) | Go to Step (10) |
| 8 | <ul style="list-style-type: none"> • Inspect the electronic throttle wire harness connector and terminals for damage, corrosion or contamination Did you find a problem? | | Repair the circuit as necessary. Refer to Wiring Repairs in Engine Electrical. | Go to Step (9) |
| 9 | <ul style="list-style-type: none"> • Replace electronic throttle Is the replacement complete? | | Go to Step (11) | - |
| 10 | <ul style="list-style-type: none"> • Key OFF • Disconnect ECM connector C001 • Using a DVOM check for continuity between throttle connector C017 sensor ground pin 2 and ECM connector sensor ground pin 20 Do have continuity between them? | | Go to Step (6) | Repair the circuit as necessary. Refer to Wiring Repairs in Engine Electrical. |

| Step | Action | Value(s) | Yes | No |
|------|---|----------|-----------|------------------------|
| 11 | <ul style="list-style-type: none"> • Remove all test equipment except the DST. • Connect any disconnected components, fuses, etc. • Using the DST clear DTC information from the ECM. • Turn the ignition OFF and wait 30 seconds. • Start the engine and operate the vehicle to full operating temperature • Observe the MIL • Observe engine performance and drivability • After operating the engine within the test parameters of DTC-223 check for any stored codes. <p>Does the engine operate normally with no stored codes?</p> | | System OK | Go to OBD System Check |

DTC-359 Fuel Run-out Longer Than Expected

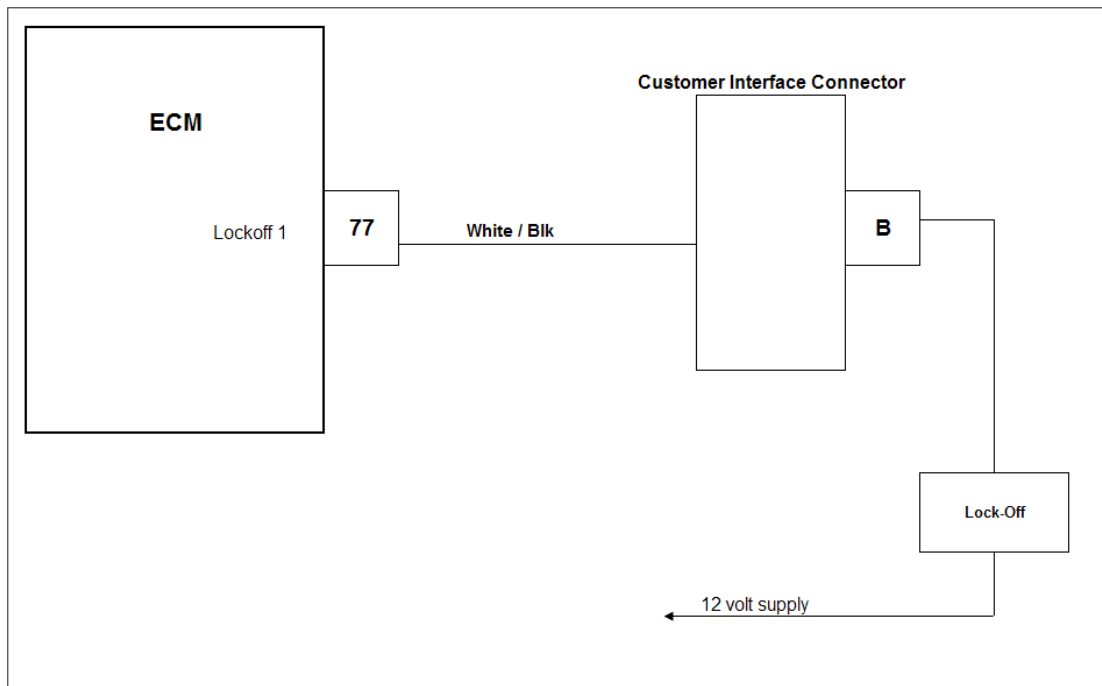

Conditions for Setting the DTC

- LPG shut off valve
- Check Condition-Key OFF
- Fault Condition-Engine run down time greater than 10 seconds
- MIL-ON

Circuit Description

The LPG shut off valve is supplied system battery power from the VSW fused source. The ECM then provides a path to ground to turn the valve on. This fault will set in the event the engine continues to run for more than 10 seconds after the key is turned off. This fault indicates a possible problem with the electric LPG shut off solenoid.

DTC-359 Fuel Run-out Longer Than Expected

| Step | Action | Value(s) | Yes | No |
|------|--|----------------|---|------------------------|
| 1 | Did you perform the On-Board (OBD) System Check? | - | Go to Step (2) | |
| 2 | <ul style="list-style-type: none"> • Disconnect the LPG shut off solenoid connector C003 • Using a DVOM check for power across terminals A and B while cranking the engine, then turn the key to the OFF position Did the voltage immediately turn OFF with the key cycle? | System Voltage | Go to Step (3) | Go to Step (5) |
| 3 | <ul style="list-style-type: none"> • Turn off the LPG manual valve at the fuel tank • Start the engine and let it idle until the engine stops. (THIS MAY TAKE SEVERAL MINUTES) Did the engine ever stop? | | Intermittent problem. See intermittent problems in the electrical section of this manual. | Go to Step (4) |
| 4 | <ul style="list-style-type: none"> • Replace the LPG shut off solenoid Is the replacement complete? | | Go to Step (8) | - |
| 5 | <ul style="list-style-type: none"> • Key OFF • Disconnect the ECM wire harness connector C001 • Using a DVOM check for continuity between ECM pin 12 and engine ground Do you have continuity? | | Repair the LPG solenoid control short to ground | Go to Step (6) |
| 6 | <ul style="list-style-type: none"> • Inspect the ECM wire harness and connector for damage corrosion or contamination Did you find a problem? | | Correct the problem as required. See wire harness repair. | Go to Step (7) |
| 7 | <ul style="list-style-type: none"> • Replace the ECM Is the replacement complete? | | Go to Step (8) | - |
| 8 | <ul style="list-style-type: none"> • Remove all test equipment except the DST. • Connect any disconnected components, fuses, etc. • Using the DST clear DTC information from the ECM. • Turn the ignition OFF and wait 30 seconds. • Start the engine and operate the vehicle to full operating temperature • Observe the MIL • Observe engine performance and drivability • After operating the engine within the test parameters of DTC-359 check for any stored codes. Does the engine operate normally with no stored codes? | | System OK | Go to OBD System Check |

DTC 520-Oil Pressure Low Stage 1

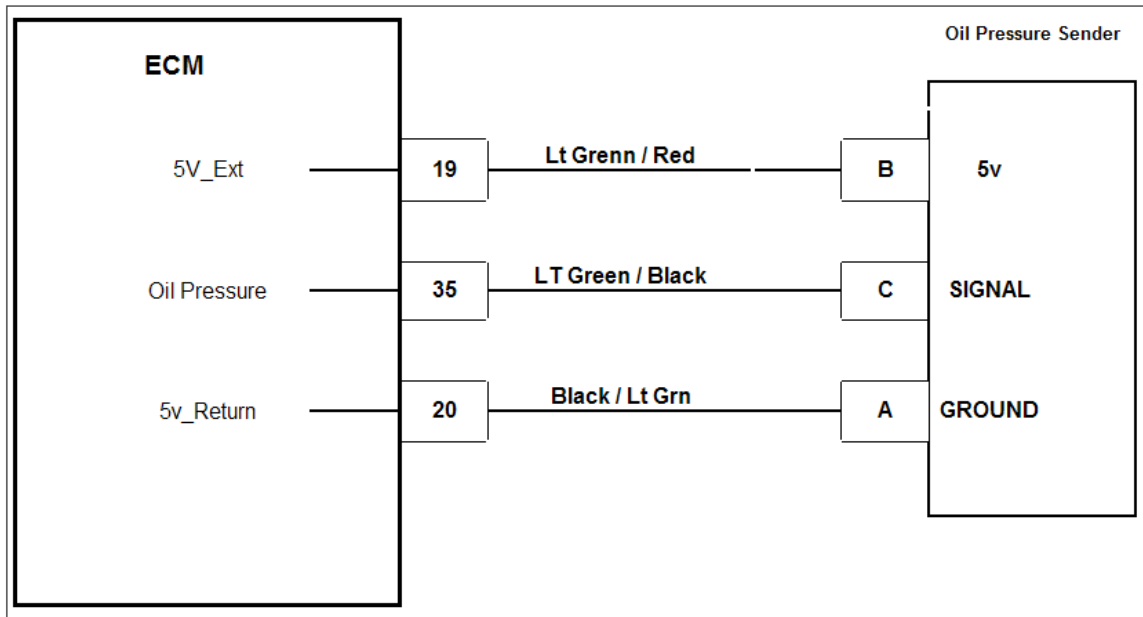

Conditions for Setting the DTC

- Engine Oil Pressure low.
- Check Condition-Engine running for 20 seconds or more with engine speed greater than 600 rpm.
- Fault Condition- Oil pressure less than 15 PSI if engine speed is less than 1,400rpm
- Fault Condition – Oil pressure less than 30 PSI if engine speed is greater than 1,450rpm
- MIL is illuminated

Circuit Description

The Oil Pressure Sender is used to communicate the oil pressure condition to the ECM. Engine damage can occur if the engine is operated with low oil pressure. The ECM sends a 5v signal to the oil pressure sender. The sender will report a signal back to the ECM on the signal wire depending on the pressure that is applied on its diaphragm. The voltage is linear in comparison to the pressure applied (see chart below). The MIL command is ON and the engine will shut down in the event of this fault to help prevent possible engine damage.

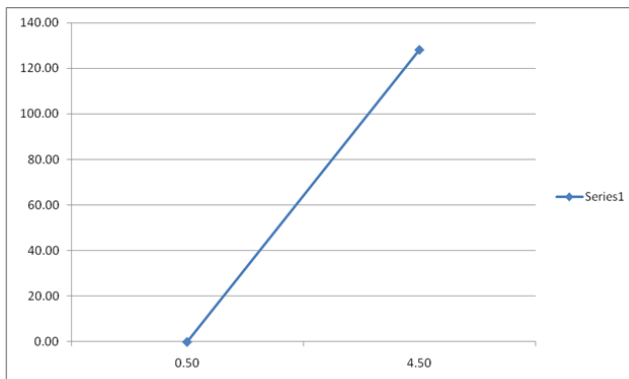

| Code # | Code Name | RPM | Pressure |
|--------|----------------------|----------|----------|
| 520 | Oil Pres Low Stage 1 | <= 1,400 | 15 psi |
| 520 | Oil Pres Low Stage 1 | >= 1,450 | 30 psi |
| 524 | Oil Pres Low Stage 2 | <= 1,400 | 8 psi |
| 524 | Oil Pres Low Stage 2 | >= 1,450 | 25 psi |

DTC 520-Oil Pressure Low Stage 1

| Step | Action | Value(s) | Yes | No |
|------|--|----------|--|--|
| 1 | Did you perform the On-Board (OBD) System Check? | - | Go to Step (2) | Go to OBD System Check Section |
| 2 | <ul style="list-style-type: none"> Verify that the engine has oil pressure using a mechanical oil pressure gauge before proceeding with this chart. See Engine Specifications Section 1F. Does the engine have oil pressure above 8 NGE? | 8 NGE | Go to Step (3) | Repair faulty Oiling System |
| 3 | <ul style="list-style-type: none"> Key ON, Engine Running DST connected in System Data Mode Clear DTC 524 Warm the engine by idling until the ECT temperature is above 160 degrees F. and has been running for at least 20 seconds or more Increase engine speed above 600 RPM Does DTC 524 reset and cause the engine to shut down? | | Go to Step (4) | Intermittent problem Go to Intermittent section |
| 4 | <ul style="list-style-type: none"> With a volt meter, check terminal B on the sensor for a 5 volt reference from the ECM. Do you have 5 volts on terminal B? | 5v | Go to Step (6) | Go to Step (5) |
| 5 | <ul style="list-style-type: none"> With a volt meter, check terminal 19 on the ECM for a 5 volt reference. Do you have a 5v reference coming out of the ECM? | 5v | Repair faulty wiring between ECM and Oil pressure sensor | Go to Step (8) |
| 6 | <ul style="list-style-type: none"> With the oil pressure sender connected check for a signal coming out of terminal C. Do you have a voltage signal coming out of terminal C? | | Go to Step (7) | Replace faulty oil pressure sender |
| 7 | <ul style="list-style-type: none"> With the oil pressure sender connected check for a signal at terminal 35 of the ECM. Do you have a signal voltage at pin 35 of the ECM? | | Go to Step (8) | Repair faulty wiring between terminal C and Terminal 25. |

| Step | Action | Value(s) | Yes | No |
|------|--|----------|----------------|------------------------|
| 8 | <ul style="list-style-type: none"> • Replace DEPR / ECM Is the replacement complete? | | Go to Step (9) | - |
| 9 | <ul style="list-style-type: none"> • Remove all test equipment except the DST. • Connect any disconnected components, fuses, etc. • Using the DST clear DTC information from the ECM. • Turn the ignition OFF and wait 30 seconds. • Start the engine and operate the vehicle to full operating temperature • Observe the MIL • Observe engine performance and drivability • After operating the engine within the test parameters of DTC-524 check for any stored codes. Does the engine operate normally with no stored codes? | | System OK | Go to OBD System Check |

DTC 524-Oil Pressure Low Stage 2

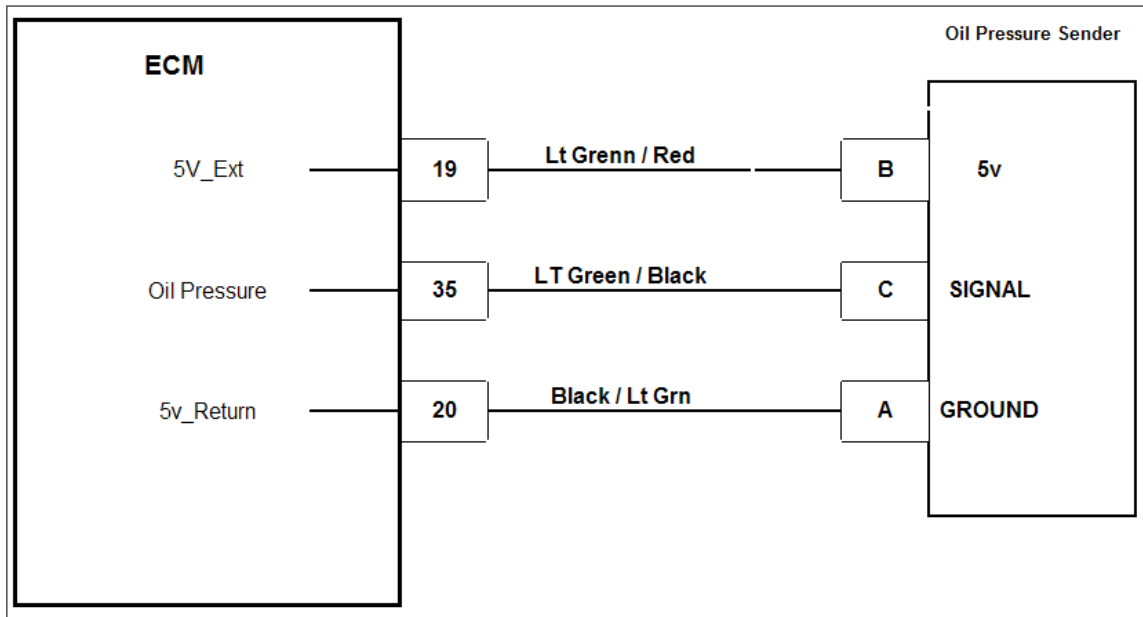

Conditions for Setting the DTC

- Engine Oil Pressure low.
- Check Condition-Engine running for 20 seconds or more with engine speed greater than 600 rpm.
- Fault Condition- Oil pressure less than 8 PSI with engine RPM less than 1,400rpm
- Fault Condition – Oil pressure less than 25psi with engine RPM greater than 1,450rpm
- Engine Shut Down.

Circuit Description

The Oil Pressure Sender is used to communicate the oil pressure condition to the ECM. Engine damage can occur if the engine is operated with low oil pressure. The ECM sends a 5v signal to the oil pressure sender. The sender will report a signal back to the ECM on the signal wire depending on the pressure that is applied on its diaphragm. The voltage is linear in comparison to the pressure applied (see chart below). The MIL command is ON and the engine will shut down in the event of this fault to help prevent possible engine damage.

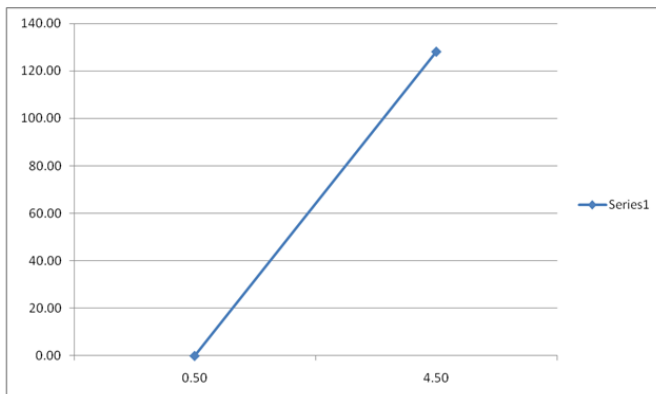

| Code # | Code Name | RPM | Pressure |
|--------|----------------------|----------|----------|
| 520 | Oil Pres Low Stage 1 | <= 1,400 | 15 psi |
| 520 | Oil Pres Low Stage 1 | >= 1,450 | 30 psi |
| 524 | Oil Pres Low Stage 2 | <= 1,400 | 8 psi |
| 524 | Oil Pres Low Stage 2 | >= 1,450 | 25 psi |

DTC 524-Oil Pressure Low Stage 2

| Step | Action | Value(s) | Yes | No |
|------|--|----------|--|--|
| 1 | Did you perform the On-Board (OBD) System Check? | - | Go to Step (2) | Go to OBD System Check Section |
| 2 | <ul style="list-style-type: none"> Verify that the engine has oil pressure using a mechanical oil pressure gauge before proceeding with this chart. See Engine Specifications Section 1F. Does the engine have oil pressure above 8 NGE? | 8 NGE | Go to Step (3) | Repair faulty Oiling System |
| 3 | <ul style="list-style-type: none"> Key ON, Engine Running DST connected in System Data Mode Clear DTC 524 Warm the engine by idling until the ECT temperature is above 160 degrees F. and has been running for at least 20 seconds or more Increase engine speed above 600 RPM Does DTC 524 reset and cause the engine to shut down? | | Go to Step (4) | Intermittent problem Go to Intermittent section |
| 4 | <ul style="list-style-type: none"> With a volt meter, check terminal B on the sensor for a 5 volt reference from the ECM. Do you have 5 volts on terminal B? | 5v | Go to Step (6) | Go to Step (5) |
| 5 | <ul style="list-style-type: none"> With a volt meter, check terminal 19 on the ECM for a 5 volt reference. Do you have a 5v reference coming out of the ECM? | 5v | Repair faulty wiring between ECM and Oil pressure sensor | Go to Step (8) |
| 6 | <ul style="list-style-type: none"> With the oil pressure sender connected check for a signal coming out of terminal C. Do you have a voltage signal coming out of terminal C? | | Go to Step (7) | Replace faulty oil pressure sender |
| 7 | <ul style="list-style-type: none"> With the oil pressure sender connected check for a signal at terminal 35 of the ECM. Do you have a signal voltage at pin 35 of the ECM? | | Go to Step (8) | Repair faulty wiring between terminal C and Terminal 25. |

| Step | Action | Value(s) | Yes | No |
|------|--|----------|----------------|------------------------|
| 8 | <ul style="list-style-type: none"> • Replace DEPR / ECM Is the replacement complete? | | Go to Step (9) | - |
| 9 | <ul style="list-style-type: none"> • Remove all test equipment except the DST. • Connect any disconnected components, fuses, etc. • Using the DST clear DTC information from the ECM. • Turn the ignition OFF and wait 30 seconds. • Start the engine and operate the vehicle to full operating temperature • Observe the MIL • Observe engine performance and drivability • After operating the engine within the test parameters of DTC-524 check for any stored codes. Does the engine operate normally with no stored codes? | | System OK | Go to OBD System Check |

DTC 521- Oil Pressure High

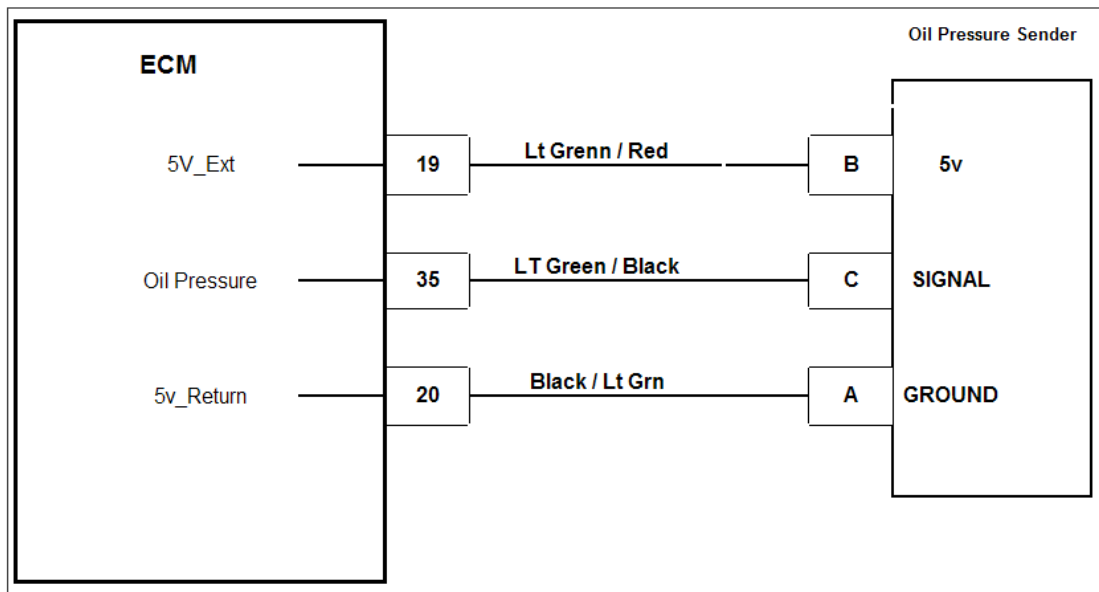

Conditions for Setting the DTC

- Engine Oil Pressure low.
- Check Condition-Engine running for 20 seconds or more with engine speed greater than 600 rpm.
- Fault Condition- Oil pressure greater than 95 PSI for 5 or more seconds
- Engine Shut Down.

Circuit Description

The Oil Pressure Sender is used to communicate the oil pressure condition to the ECM. Engine damage can occur if the engine is operated with low oil pressure. The ECM sends a 5v signal to the oil pressure sender. The sender will report a signal back to the ECM on the signal wire depending on the pressure that is applied on its diaphragm. The voltage is linear in comparison to the pressure applied (see chart below). The MIL command is ON and the engine will shut down in the event of this fault to help prevent possible engine damage.

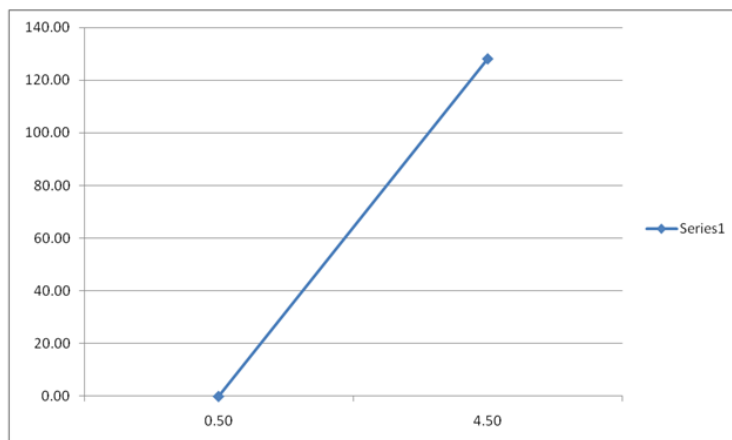

DTC 521-Oil Pressure High

| Step | Action | Value(s) | Yes | No |
|------|--|----------|---|--------------------------------|
| 1 | Did you perform the On-Board (OBD) System Check? | - | Go to Step (2) | Go to OBD System Check Section |
| 2 | <ul style="list-style-type: none"> Verify that the engine has oil pressure using a mechanical oil pressure gauge before proceeding with this chart. See Engine Specifications Section 1F. Does the engine have oil pressure above 95 NGE? | | Repair faulty oiling system | Go to step (3) |
| 3 | <ul style="list-style-type: none"> With the engine running measure the signal voltage on terminal C of the oil pressure sender. Do you have more than 3.8v? | > 3.8v. | Replace faulty oil pressure sender. | Go to step (4) |
| 4 | <ul style="list-style-type: none"> With the engine running measure the signal voltage on terminal 35 of the ECM. Do you have more than 3.8v? | > 3.8v. | Repair faulty wiring between terminal C and 25. | Replace faulty DEPR / ECM |

DTC 523- Oil Pressure Sender high voltage

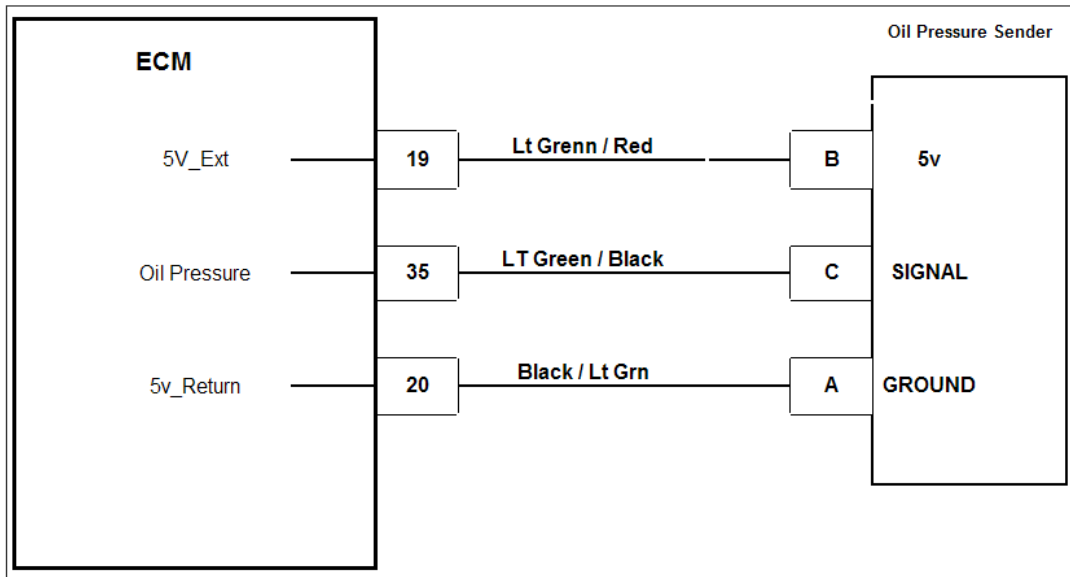

Conditions for Setting the DTC

- Engine Oil Pressure low.
- Check Condition-Engine running for 20 seconds or more with engine speed greater than 600 rpm.
- Fault Condition- Voltage on terminal 35 is greater than 4.8v for more than 1 second
- MIL-ON during active fault and for 2 seconds after active fault.

Circuit Description

The Oil Pressure Sender is used to communicate the oil pressure condition to the ECM. Engine damage can occur if the engine is operated with low oil pressure. The ECM sends a 5v signal to the oil pressure sender. The sender will report a signal back to the ECM on the signal wire depending on the pressure that is applied on its diaphragm. The voltage is linear in comparison to the pressure applied (see chart below). The MIL command is ON and the engine will shut down in the event of this fault to help prevent possible engine damage.

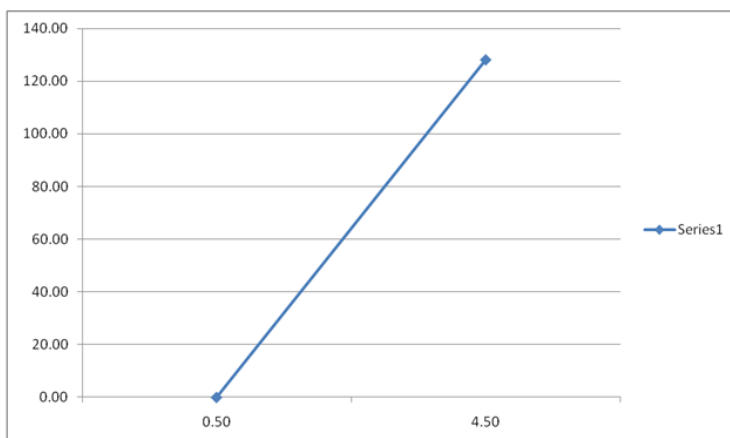

DTC 523- Oil Pressure Sender high voltage

| Step | Action | Value(s) | Yes | No |
|------|---|----------|-------------------------------------|--|
| 1 | Did you perform the On-Board (OBD) System Check? | - | Go to Step (2) | Go to OBD System Check Section |
| 2 | <ul style="list-style-type: none"> Using the Diagnostic Service Tool (DST) check the OILP_raw value on the "RAW VOLTS" page. Is the voltage over 4.8 volts | > 4.8v | Go to Step (3) | Replace faulty DEPR / ECM |
| 3 | <ul style="list-style-type: none"> Using a voltmeter measure the voltage at terminal 35 of the DEPR / ECM Is the voltage over 4.8 volts? | > 4.8v | Go to Step (4) | Replace faulty DEPR / ECM |
| 4 | <ul style="list-style-type: none"> Using a voltmeter measure the voltage at terminal C at the oil pressure sender. Is the voltage over 4.8 volts? | > 4.8v | Replace faulty oil pressure sender. | Intermittent problem, go to intermittent section |

DTC 522- Oil Pressure Sender low voltage

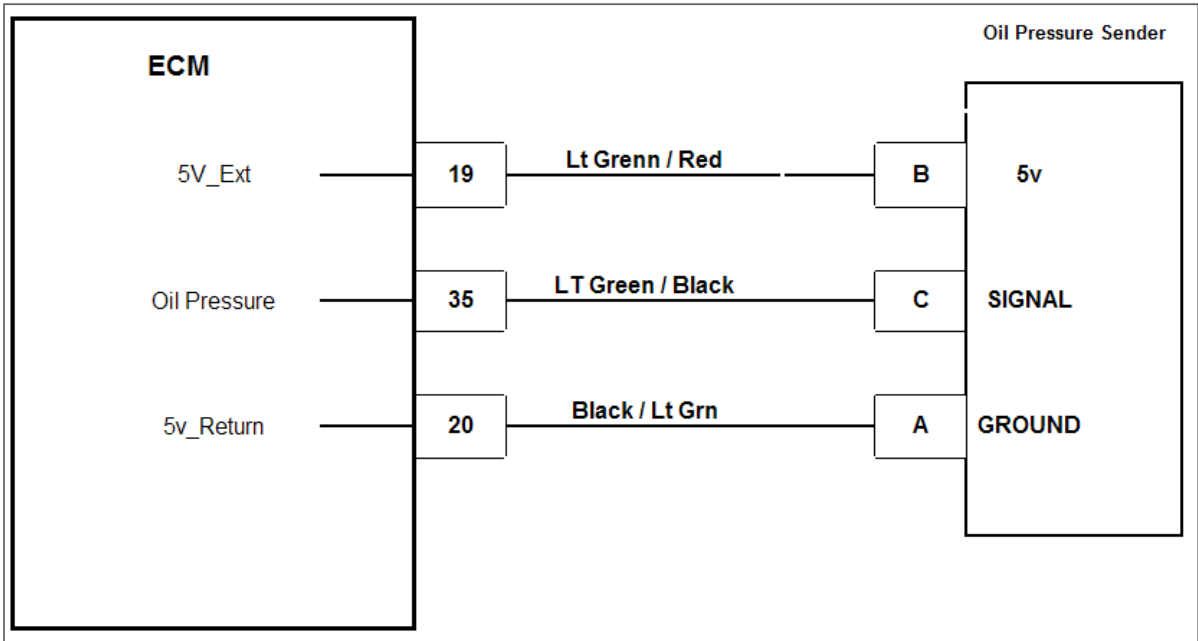

Conditions for Setting the DTC

- Engine Oil Pressure low.
- Check Condition-Engine running for 20 seconds or more with engine speed greater than 600 rpm.
- Fault Condition- Voltage on terminal 35 is less than 0.2v for more than 1 second
- MIL-ON during active fault and for 2 seconds after active fault.

Circuit Description

The Oil Pressure Sender is used to communicate the oil pressure condition to the ECM. Engine damage can occur if the engine is operated with low oil pressure. The ECM sends a 5v signal to the oil pressure sender. The sender will report a signal back to the ECM on the signal wire depending on the pressure that is applied on its diaphragm. The voltage is linear in comparison to the pressure applied (see chart below). The MIL command is ON and the engine will shut down in the event of this fault to help prevent possible engine damage.

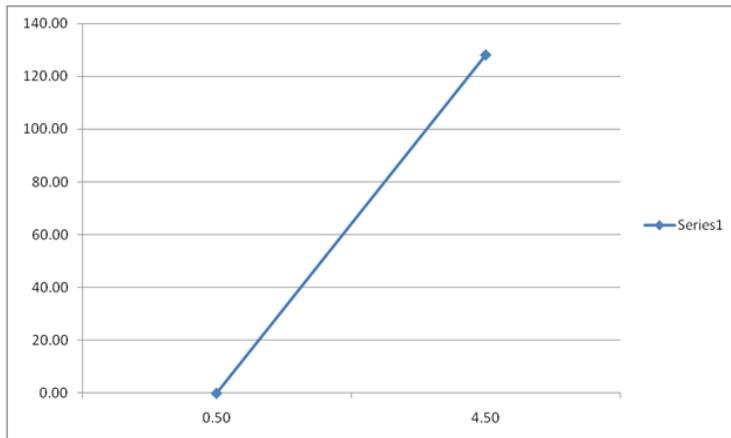

DTC 522- Oil Pressure Sender low voltage

| Step | Action | Value(s) | Yes | No |
|------|--|----------|-------------------------------------|--|
| 1 | Did you perform the On-Board (OBD) System Check? | - | Go to Step (2) | Go to OBD System Check Section |
| 2 | <ul style="list-style-type: none"> Using the Diagnostic Service Tool (DST) check the OILP_raw value on the "RAW VOLTS" page. Is the voltage less than 0.2 volts | < 0.2v | Go to Step (3) | Replace faulty DEPR / ECM |
| 3 | <ul style="list-style-type: none"> Using a voltmeter measure the voltage at terminal 35 of the DEPR / ECM Is the voltage less than 0.2 volts? | < 0.2v | Go to Step (4) | Replace faulty DEPR / ECM |
| 4 | <ul style="list-style-type: none"> Using a voltmeter measure the voltage at terminal C at the oil pressure sender. Is the voltage less than 0.2 volts? | < 0.2v | Replace faulty oil pressure sender. | Intermittent problem, go to intermittent section |

DTC 562-System Voltage Low

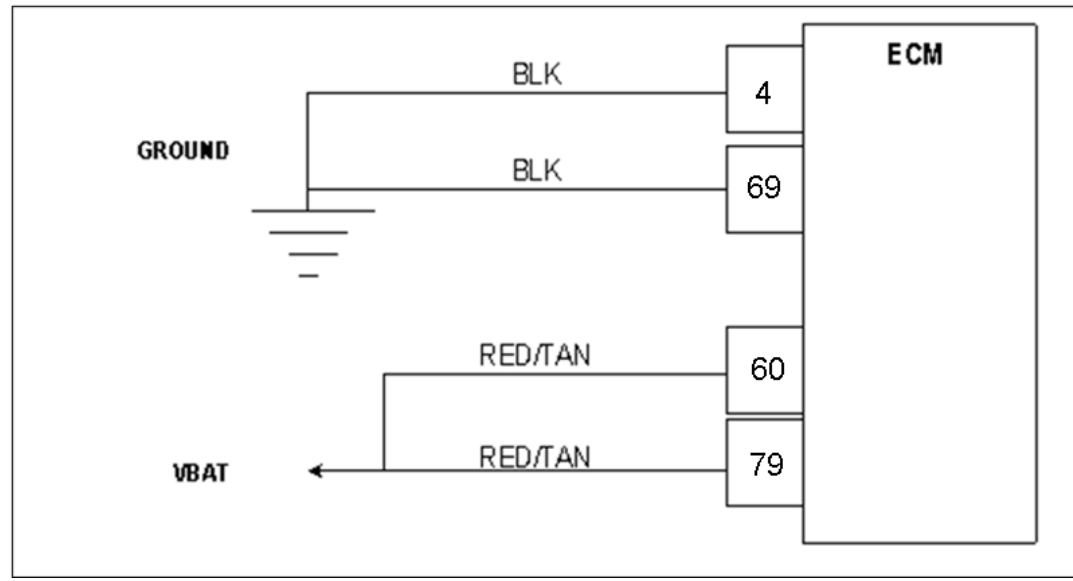

Conditions for Setting the DTC

- System Voltage to ECM
- Check Condition-Key on with engine speed greater than 1500 RPM
- Fault Condition-Battery voltage at ECM less than 9.0
- Fault Condition is present for longer than 5 seconds.
- MIL-ON for active fault
- Adaptive-Disabled

Circuit Description

The battery voltage powers the ECM and must be measured to correctly to properly operate injector drivers, solenoid valves and ignition coils. This fault will set if the ECM detects system voltage less than 9.00 volts while the alternator should be charging. The adaptive learn is disabled during this fault.

DTC 562-System Voltage Low

| Step | Action | Value(s) | Yes | No |
|------|--|----------|--|--------------------------------|
| 1 | Did you perform the On-Board (OBD) System Check? | - | Go to Step (2) | Go to OBD System Check Section |
| 2 | <ul style="list-style-type: none"> • Key ON, Engine Running • DST (Diagnostic Scan Tool) connected in System Data Mode Does DST display system voltage greater than 9.50 volts? | - | Intermittent problem Go to Engine Electrical Intermittent section | Go to Step (3) |
| 3 | <ul style="list-style-type: none"> • Check battery condition Is it OK? | - | Go to Step (4) | Replace Battery |
| 4 | <ul style="list-style-type: none"> • Check charging system Is it OK? | - | Go to Step (5) | Repair charging System |
| 5 | <ul style="list-style-type: none"> • Key OFF • Disconnect the ECM connector C001 • Check the voltage between ECM connector C001 pins 60, 79 and engine ground. • Measure voltage with DVOM between each pin and engine ground Is the voltage greater than for each pin 9.50 volts? | - | Repair ECM Ground circuit. Go to Power and Ground section in engine Electrical | Go to Step (6) |
| 6 | <ul style="list-style-type: none"> • Check the voltage at ECM connector pins 4 and 69 • Measure voltage with DVOM between each pin and battery positive Is the voltage greater than 9.50 volts? | - | Repair ECM power circuit. Go to Power and Ground section in engine Electrical | Go to Step (7) |
| 7 | <ul style="list-style-type: none"> • Replace ECM Is the replacement complete? | - | Go to Step (8) | - |
| 8 | <ul style="list-style-type: none"> • Remove all test equipment except the DST. • Connect any disconnected components, fuses, etc. • Using the DST clear DTC information from the ECM. • Turn the ignition OFF and wait 30 seconds. • Start the engine and operate the vehicle to full operating temperature • Observe the MIL • Observe engine performance and drivability • After operating the engine within the test parameters of DTC-562 check for any stored codes. Does the engine operate normally with no stored codes? | - | System OK | Go to OBD System Check |

DTC 601-Flash Checksum Invalid

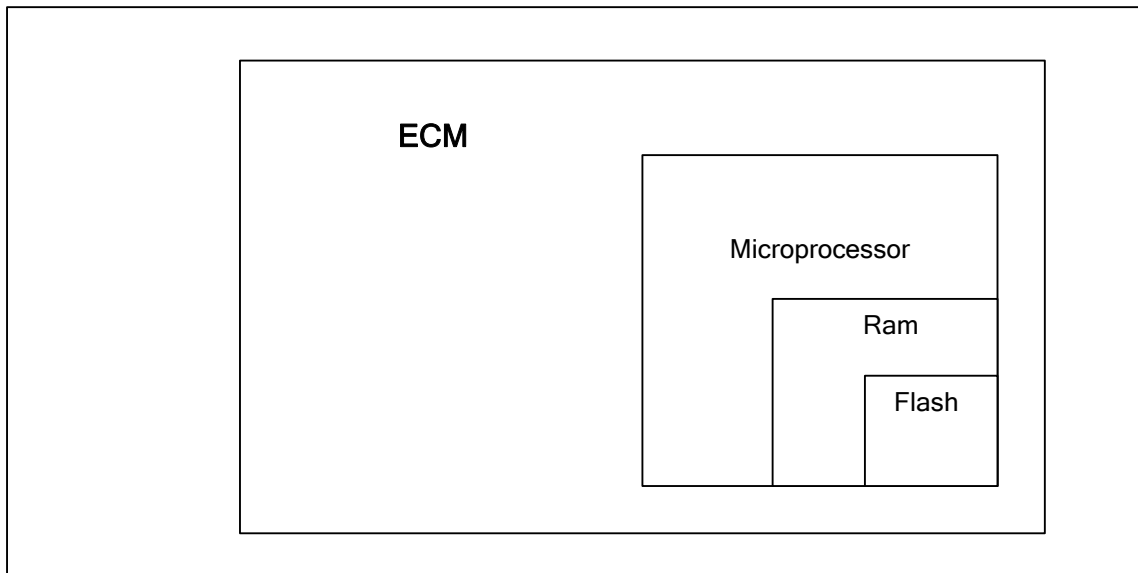

Conditions for Setting the DTC

- Engine Control Module
- Check Condition-Key on
- Fault Condition-Internal microprocessor error
- MIL-ON
- Engine Shutdown will occur

Circuit Description

The ECM has several internal checks that must be satisfied each time an instruction is executed. Several different things can happen within the microprocessor that will cause this fault. The ECM will attempt to reset itself in the event this fault is set. The MIL command is on and will remain on until the code is cleared using the DST. The engine will shutdown when this fault occurs.

DTC 601-Flash Checksum Invalid

| Step | Action | Value(s) | Yes | No |
|------|--|----------|----------------|--|
| 1 | Did you perform the On-Board (OBD) System Check? | - | Go to Step (2) | Go to OBD System Check Section |
| 2 | <ul style="list-style-type: none"> • Key ON, Engine Running • DST (Diagnostic Scan Tool) connected in System Data Mode • Clear system fault code Does DTC 601 reset with the engine idling? | | Go to Step (3) | Intermittent problem Go to Intermittent section |
| 3 | <ul style="list-style-type: none"> • Check ECM power and ground circuits Did the power and ground circuits check OK? | | Go to Step (4) | Repair the circuit as necessary. Refer to Wiring Repairs in Engine Electrical. |
| 4 | <ul style="list-style-type: none"> • Replace ECM Is the replacement complete? | | Go to Step (5) | - |
| 5 | <ul style="list-style-type: none"> • Remove all test equipment except the DST. • Connect any disconnected components, fuses, etc. • Using the DST clear DTC information from the ECM. • Turn the ignition OFF and wait 30 seconds. • Start the engine and operate the vehicle to full operating temperature • Observe the MIL • Observe engine performance and drivability • After operating the engine within the test parameters of DTC-601 check for any stored codes. Does the engine operate normally with no stored codes? | | System OK | Go to OBD System Check |

DTC 604-RAM Failure

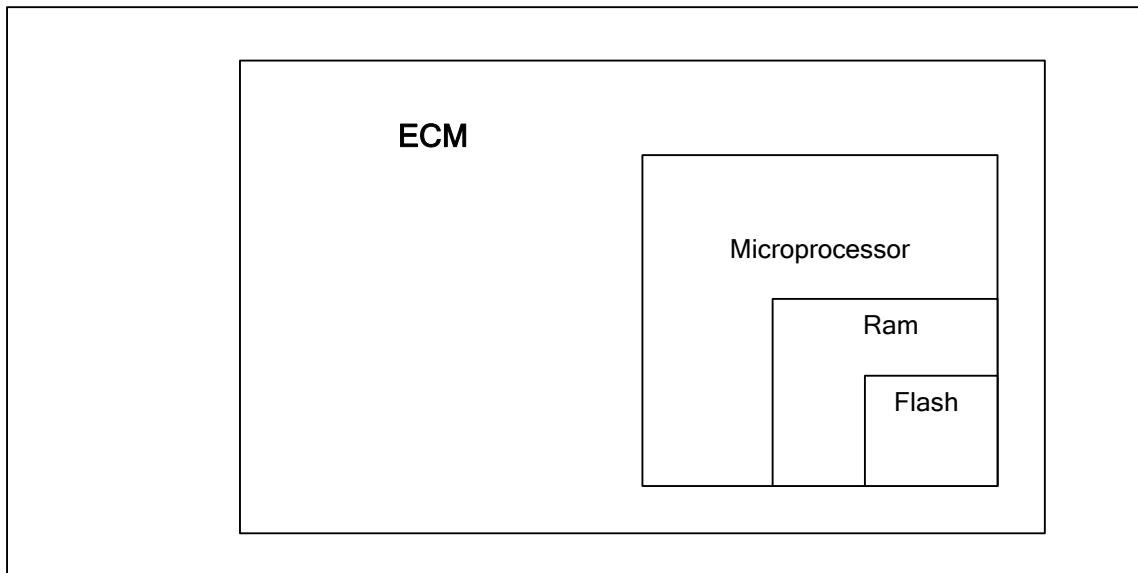

Conditions for Setting the DTC

- Engine Control Module
- Check Condition-Key on
- Fault Condition-Internal microprocessor error
- MIL-ON
- Engine Shutdown will occur

Circuit Description

The ECM has several internal checks that must be satisfied each time an instruction is executed. Several different things can happen within the microprocessor that will cause this fault. The ECM will attempt to reset itself in the event this fault is set. The MIL command is on and will remain on until the code is cleared using the DST. The engine will shutdown if this fault occurs.

DTC 604-RAM Failure

| Step | Action | Value(s) | Yes | No |
|------|--|----------|----------------|--|
| 1 | Did you perform the On-Board (OBD) System Check? | - | Go to Step (2) | Go to OBD System Check Section |
| 2 | <ul style="list-style-type: none"> • Key ON, Engine Running • DST (Diagnostic Scan Tool) connected in System Data Mode • Clear system fault code Does DTC 604 reset with the engine idling? | | Go to Step (3) | Intermittent problem Go to Intermittent section |
| 3 | <ul style="list-style-type: none"> • Check ECM power and ground circuits Did the power and ground circuits check OK? | | Go to Step (4) | Repair the circuit as necessary. Refer to Wiring Repairs in Engine Electrical. |
| 4 | <ul style="list-style-type: none"> • Replace ECM Is the replacement complete? | | Go to Step (5) | - |
| 5 | <ul style="list-style-type: none"> • Remove all test equipment except the DST. • Connect any disconnected components, fuses, etc. • Using the DST clear DTC information from the ECM. • Turn the ignition OFF and wait 30 seconds. • Start the engine and operate the vehicle to full operating temperature • Observe the MIL • Observe engine performance and drivability • After operating the engine within the test parameters of DTC-604 check for any stored codes. Does the engine operate normally with no stored codes? | | System OK | Go to OBD System Check |

DTC 606-COP Failure

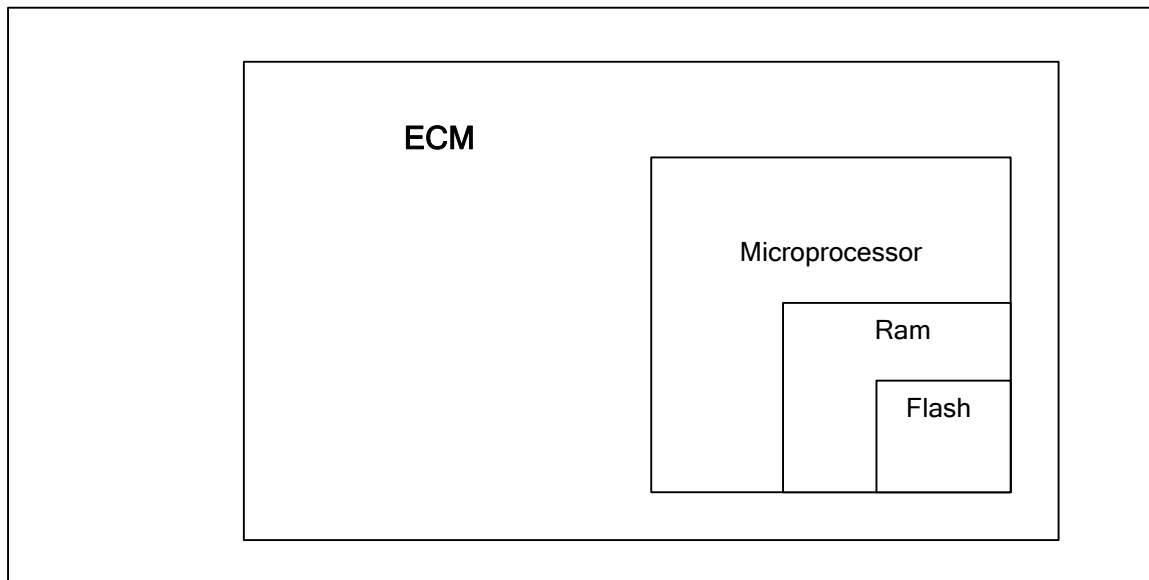

Conditions for Setting the DTC

- Engine Control Module
- Check Condition-Key on
- Fault Condition-Internal microprocessor error
- MIL-ON
- Engine Shutdown will occur

Circuit Description

The ECM has several internal checks that must be satisfied each time an instruction is executed. Several different things can happen within the microprocessor that will cause this fault. The ECM will attempt to reset itself in the event this fault is set. The MIL command is on and will remain on until the code is cleared using the DST. The engine will shutdown if this fault occurs.

DTC 606-COP Failure

| Step | Action | Value(s) | Yes | No |
|------|--|----------|----------------|---|
| 1 | Did you perform the On-Board (OBD) System Check? | - | Go to Step (2) | Go to OBD System Check Section |
| 2 | <ul style="list-style-type: none"> • Key ON, Engine Running • DST (Diagnostic Scan Tool) connected in System Data Mode • Clear system fault code Does DTC 606 reset with the engine idling? | | Go to Step (3) | Intermittent problem Go to Intermittent section |
| 3 | <ul style="list-style-type: none"> • Check ECM power and ground circuits Are the power and ground circuits OK? | | Go to Step (4) | Repair the circuit as necessary. Refer to Wiring Repairs in Engine Electrical. |
| 4 | <ul style="list-style-type: none"> • Replace ECM Is the replacement complete? | | Go to Step (5) | - |
| 5 | <ul style="list-style-type: none"> • Remove all test equipment except the DST. • Connect any disconnected components, fuses, etc. • Using the DST clear DTC information from the ECM. • Turn the ignition OFF and wait 30 seconds. • Start the engine and operate the vehicle to full operating temperature • Observe the MIL • Observe engine performance and drivability • After operating the engine within the test parameters of DTC-606 check for any stored codes. Does the engine operate normally with no stored codes? | | System OK | Go to OBD System Check |

DTC 642-External 5 Volt 1 Reference Low

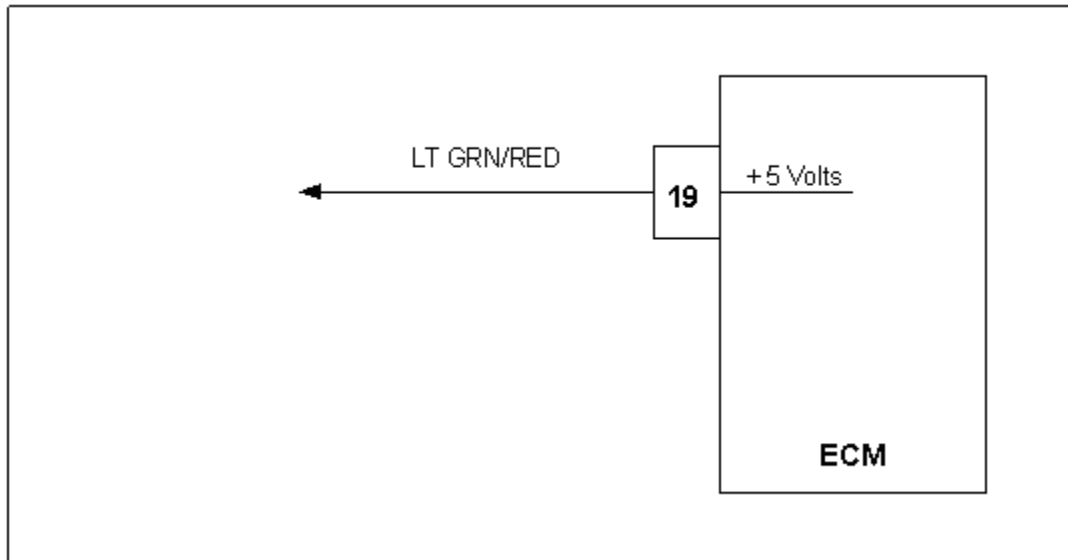

Conditions for Setting the DTC

- External 5 volt reference
- Check Condition-Engine cranking or running
- Fault Condition-5 volt reference voltage lower than 4.60 volts
- MIL-ON during active fault
- Adaptive-Disabled during active fault

Circuit Description

The External 5 volt supply powers many of the sensors and other components of the fuel system. The accuracy of the 5 volt supply is very important to the accuracy of the powered sensors and fuel control by the ECM. The ECM is able to determine if they are overloaded, shorted, or otherwise out of specification by monitoring the 5 volt supply. This fault will set if the 5 volt reference is below 4.60 volts. Adaptive Learn will be disabled during this fault

DTC 642 External 5 Volt 1 Reference Low

| Step | Action | Value(s) | Yes | No |
|------|---|----------|----------------|--|
| 1 | Did you perform the On-Board (OBD) System Check? | - | Go to Step (2) | Go to OBD System Check Section |
| 2 | <ul style="list-style-type: none"> • Key ON, Engine Running • DST (Diagnostic Scan Tool) connected in System Fault Mode Does DST display DTC 642? | | Go to Step (3) | Intermittent problem Go to Intermittent section |
| 3 | <ul style="list-style-type: none"> • Key OFF • Disconnect ECM connector C001 • Using DVOM check for continuity between ECM 5 volt reference pin 19 and engine ground Do you have continuity? | | Go to Step (5) | Go to Step (4) |
| 4 | <ul style="list-style-type: none"> • Replace ECM Is the replacement complete? | | Go to Step (7) | - |
| 5 | <ul style="list-style-type: none"> • While monitoring DVOM for continuity between ECM 5 volt reference and engine ground • Disconnect each sensor (below) one at a time to find the shorted 5 volt reference. When continuity to ground is lost the last sensor disconnected is the area of suspicion. Inspect the 5 volt reference supply wire leads for shorts before replacing the sensor. • TMAP • Electronic Throttle • FPP • Crankshaft Sensor • Camshaft Sensor While disconnecting each sensor one at a time did you loose continuity? | | Go to Step (6) | Repair shorted wire harness |
| 6 | <ul style="list-style-type: none"> • Replace the last disconnected sensor Is the replacement complete? | | Go to Step (7) | - |

| Step | Action | Value(s) | Yes | No |
|------|---|----------|-----------|------------------------|
| 7 | <ul style="list-style-type: none"> • Remove all test equipment except the DST. • Connect any disconnected components, fuses, etc. • Using the DST clear DTC information from the ECM. • Turn the ignition OFF and wait 30 seconds. • Start the engine and operate the vehicle to full operating temperature • Observe the MIL • Observe engine performance and drivability • After operating the engine within the test parameters of DTC-642 check for any stored codes. <p>Does the engine operate normally with no stored codes?</p> | | System OK | Go to OBD System Check |

DTC 643-External 5 Volt 1 Reference High

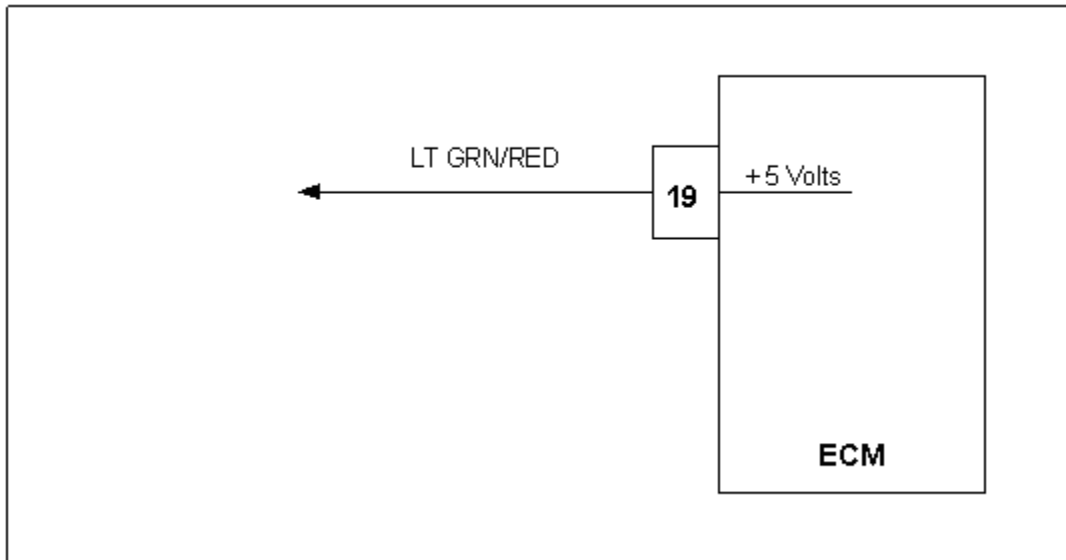

Conditions for Setting the DTC

- External 5 volt reference
- Check Condition-Engine cranking or running
- Fault Condition-5 volt reference higher than 5.40 volts
- MIL-ON during active fault
- Adaptive-Disabled during active fault

Circuit Description

The External 5 volt supply powers many of the sensors and other components in the fuel system. The accuracy of the 5 volt supply is very important to the accuracy of the powered sensors and fuel control by the ECM. The ECM is able to determine if they are overloaded, shorted, or otherwise out of specification by monitoring the 5volt supply. This fault will set if the 5 volt reference is greater than 5.40 volts anytime the engine is cranking or running. Adaptive Learn will be disabled during this fault

DTC 643 External 5 Volt 1 Reference High

| Step | Action | Value(s) | Yes | No |
|------|--|----------|---|---|
| 1 | Did you perform the On-Board (OBD) System Check? | - | Go to Step (2) | Go to OBD System Check Section |
| 2 | <ul style="list-style-type: none"> • Key ON, Engine running • DST (Diagnostic Scan Tool) connected in System Data Mode Does DST display DTC 643? | | Go to Step (3) | Intermittent problem Go to Intermittent section |
| 3 | <ul style="list-style-type: none"> • Check all ECM ground connections • Refer to Engine electrical power and ground distribution. Are the ground connections OK? | | Go to Step (4) | Repair the circuit as necessary. Refer to Wiring Repairs in Engine Electrical. |
| 4 | <ul style="list-style-type: none"> • Key OFF • Disconnect ECM connector C001 • Key ON • Using DVOM check for Voltage between ECM harness wire pin 19 and engine ground Do you have voltage? | | Repair the circuit as necessary. Refer to Wiring Repairs in Engine Electrical. | Go to Step (5) |
| 5 | <ul style="list-style-type: none"> • Replace ECM Is the replacement complete? | | Go to Step (6) | - |
| 6 | <ul style="list-style-type: none"> • Remove all test equipment except the DST. • Connect any disconnected components, fuses, etc. • Using the DST clear DTC information from the ECM. • Turn the ignition OFF and wait 30 seconds. • Start the engine and operate the vehicle to full operating temperature • Observe the MIL • Observe engine performance and drivability • After operating the engine within the test parameters of DTC-643 check for any stored codes. Does the vehicle engine normally with no stored codes? | | System OK | Go to OBD System Check |

DTC 650-MIL Control Open

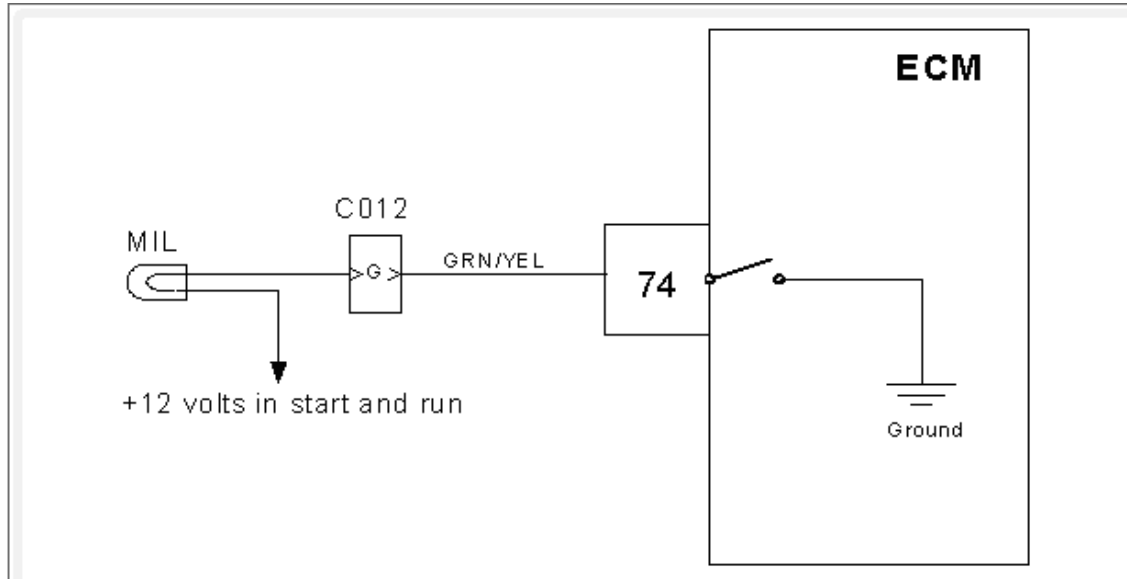

Conditions for setting the DTC

- MIL check
- Check Condition-Key ON engine OFF
- Fault Condition-ECM MIL circuit open
- MIL Command-ON

Circuit Description

The fuel system is equipped with OBD (On-Board Diagnostics). The system has a dash mounted MIL (Malfunction Indicator Lamp). The MIL serves as notification of an emissions related problem. The MIL also has the ability to flash DTC codes in what is referred to as the blink code mode. It will display DTCs that have been stored due to a possible system malfunction. The following DTC charts in this manual will instruct the technician to perform the OBD system check. This simply means to verify the operation of the MIL. The lamp should illuminate when the key is in the ON position, and the engine is not running. This feature verifies that the lamp is in proper working order. If the lamp does not illuminate with the vehicle key ON and engine OFF, repair it as soon as possible. Once the engine is in start or run mode, the lamp should go off. If the lamp stays on while the engine is in the start or run mode, a current diagnostic trouble code may be set or a problem may exist with the MIL electrical wiring. The electrical schematic above shows the MIL power source supplied to the lamp. The ECM completes the circuit to ground to turn the lamp ON. This fault will set if the ECM MIL control circuit is open.

DTC 650-MIL Control Open

| Step | Action | Value(s) | Yes | No |
|------|--|----------|--|---|
| 1 | Did you perform the On-Board (OBD) System Check? | - | Go to Step (2) | Go to OBD System Check Section |
| 2 | <ul style="list-style-type: none"> • Key ON, Engine Running • DST (Diagnostic Scan Tool) connected in System Data Mode • Clear system fault code • Key OFF • Key ON Does DTC 650 reset? | | Go to Step (3) | Intermittent problem Go to Intermittent section |
| 3 | <ul style="list-style-type: none"> • Remove the MIL bulb or driver circuit • Using a DVOM check for continuity through the bulb or driver device Do you have continuity? | | Go to Step (5) | Go to Step (4) |
| 4 | <ul style="list-style-type: none"> • Replace the open bulb or driver device Is the replacement complete? | | Go to Step (8) | — |
| 5 | <ul style="list-style-type: none"> • Key OFF • Re-install the bulb or driver device • Disconnect vehicle interface connector C012 • Using a DVOM check for continuity between vehicle interface connector pin G and battery positive • Key ON Do you have continuity? | | Go to Step (6) | Repair the open circuit as required. See wire harness repair |
| 6 | <ul style="list-style-type: none"> • Disconnect ECM wire harness connector C001 • Using a DVOM check for continuity between ECM harness connector pin 74 and vehicle interface connector pin G Do you have continuity? | | Go to Step (7) | Repair the open circuit as required. See wire harness repair |
| 7 | <ul style="list-style-type: none"> • Inspect ECM wire harness connector pin 74 and vehicle interface connector pin G for damage, corrosion or contamination Did you find a problem? | | Correct the problem as required. See wiring harness repair | Go to Step (8) |

| Step | Action | Value(s) | Yes | No |
|------|---|----------|-----------|------------------------|
| 8 | <ul style="list-style-type: none"> • Remove all test equipment except the DST. • Connect any disconnected components, fuses, etc. • Using the DST clear DTC information from the ECM. • Turn the ignition OFF and wait 30 seconds. • Start the engine and operate the vehicle to full operating temperature • Observe the MIL • Observe engine performance and drivability • After operating the engine within the test parameters of DTC-650 check for any stored codes. <p>Does the engine operate normally with no stored codes?</p> | | System OK | Go to OBD System check |

DTC 685-Relay Coil Open

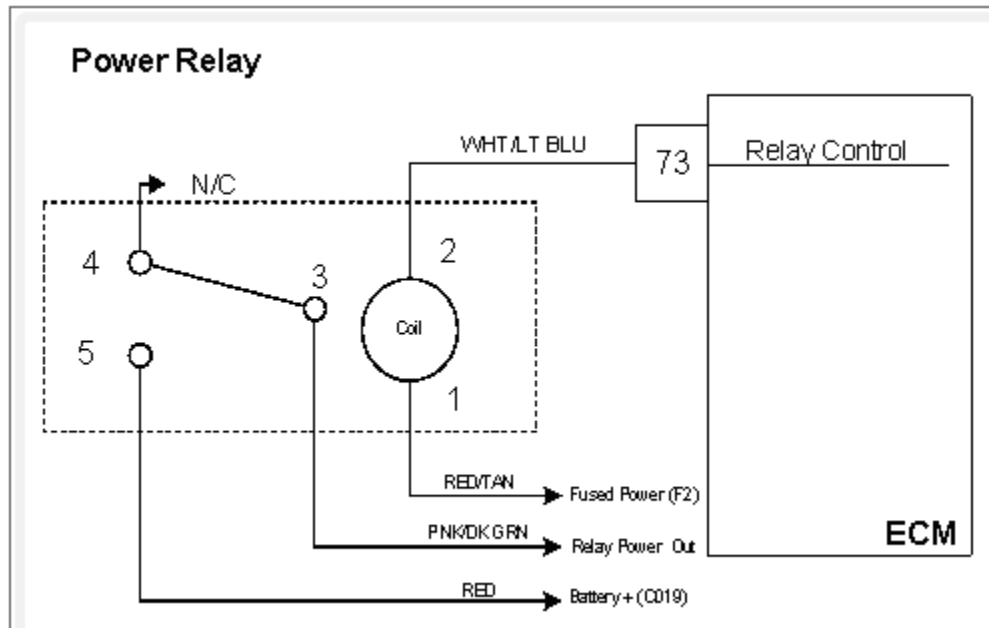

Conditions for Setting the DTC

- Power relay check
- Check Condition-Key ON
- Fault Condition-Relay coil open

Circuit Description

The power relay switches power out to various sensors, actuators and solenoids in the fuel system. This fault will set if the ECM detects an open circuit on the relay control output.

Diagnostic Aid

Relay coil resistance changes with temperature. The following diagnostic charts have steps to measure relay coil resistance values. When checking the resistance values be sure the relay is at a reasonable temperature, between +20 and +100 degrees F.

DTC 685-Relay Coil Open

| Step | Action | Value(s) | Yes | No |
|------|---|----------|-----------------|---|
| 1 | Did you perform the On-Board (OBD) System Check? | - | Go to Step (2) | Go to OBD System Check Section |
| 2 | <ul style="list-style-type: none"> • DST connected and in the system data mode • Key OFF • Remove the power relay from the fuse block • Using a DVOM check the resistance of the relay coil between terminals 1 and 2 Is the resistance value less than 100 ohms? | | Go to Step (4) | Go to Step (3) |
| 3 | <ul style="list-style-type: none"> • Replace the power relay Is the replacement complete? | | Go to Step (9) | - |
| 4 | <ul style="list-style-type: none"> • Check fuse F2 Is the fuse open? | | Replace fuse F2 | Go to Step (5) |
| 5 | <ul style="list-style-type: none"> • Disconnect ECM connector C001 • Using a DVOM check for continuity between ECM pin 73 and fuse block cavity for relay terminal 2 Do you have continuity? | | Go to Step (6) | Repair the open circuit as required. See wiring harness repairs |
| 6 | <ul style="list-style-type: none"> • Remove fuse F2 • Using a DVOM check for continuity between fuse block cavity for relay terminal 1 and the power out of the F2 fuse holder Do you have continuity? | | Go to Step (7) | Repair the open circuit as required. See wiring harness repairs |
| 7 | <ul style="list-style-type: none"> • Check all system fuses. • Check all relay placement positions in fuse block. • Run complete pin to pin checks on chassis wiring to fuel system harness. • See complete fuel system schematic for further details Did you find the problem? | | Go to Step (9) | Go to Step (8) |

| Step | Action | Value(s) | Yes | No |
|------|--|----------|----------------|------------------------|
| 8 | <ul style="list-style-type: none"> • Replace the ECM Is the replacement complete? | | Go to Step (9) | – |
| 9 | <ul style="list-style-type: none"> • Remove all test equipment except the DST. • Connect any disconnected components, fuses, etc. • Using the DST clear DTC information from the ECM. • Turn the ignition OFF and wait 30 seconds. • Start the engine and operate the vehicle to full operating temperature • Observe the MIL • Observe engine performance and drivability • After operating the engine within the test parameters of DTC-685 check for any stored codes. Does the engine operate normally with no stored codes? | | System OK | Go to OBD System Check |

DTC 686-Relay Control Ground Short

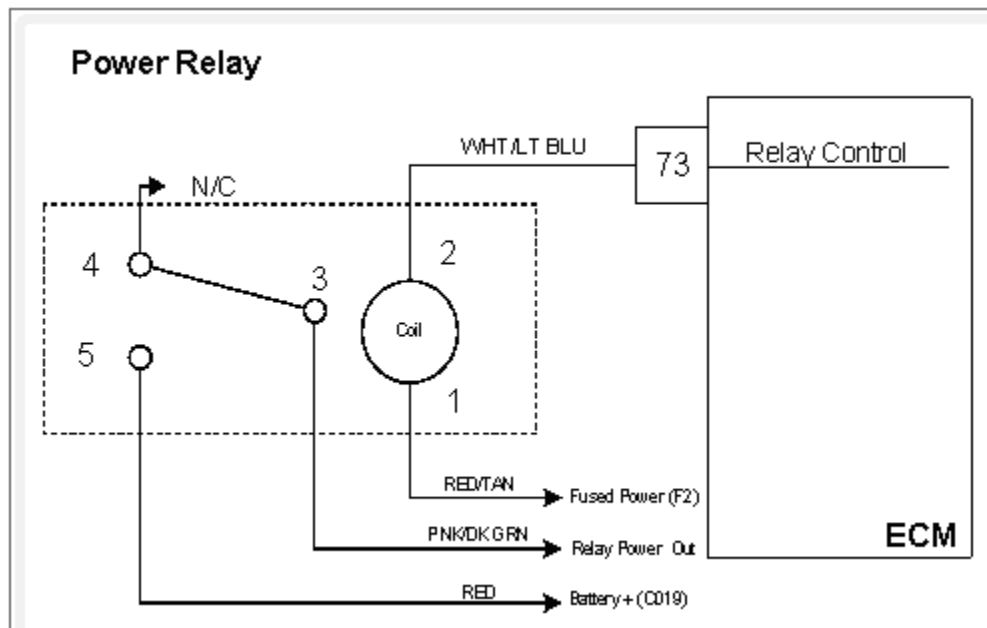

Conditions for Setting the DTC

- Power relay ground control
- Check Condition-Key ON
- Fault Condition-Relay control shorted to ground

Circuit Description

The power relay switches power out to various sensors, actuators and solenoids in the fuel system. This fault will set if the ECM detects a short to ground on the relay control output.

Diagnostic Aid

Relay coil resistance changes with temperature. The following diagnostic charts have steps to measure relay coil resistance values. When checking the resistance values be sure the relay is at a reasonable temperature, between +20 and +100 degrees F.

DTC 686-Relay Control Ground Short

| Step | Action | Value(s) | Yes | No |
|------|--|----------|---|--|
| 1 | Did you perform the On-Board (OBD) System Check? | - | Go to Step (2) | Go to OBD System Check Section |
| 2 | <ul style="list-style-type: none"> • Key ON, DST connected in the System Data mode • Clear DTC 686 • Start the engine Does DTC 686 re-set? | | Go to Step (4) | Intermittent problem Go to Intermittent section |
| 3 | <ul style="list-style-type: none"> • Disconnect ECM connector C001 • Using a DVOM check the resistance value between ECM pin 73 and engine ground Is the resistance less than 60 ohms? | | Go to Step (5) | Go to Step (7) |
| 4 | <ul style="list-style-type: none"> • Remove the power relay from the fuse block • Using a DVOM check the resistance value again between ECM pin 73 and engine ground Is the resistance less than 60 ohms? | | Repair the shorted to ground relay control circuit as necessary. See wiring harness repairs | Go to Step (6) |
| 5 | <ul style="list-style-type: none"> • Replace the power relay Is the replacement complete? | | Go to Step (8) | - |
| 6 | <ul style="list-style-type: none"> • Replace ECM Is the replacement complete? | | Go to Step (8) | - |
| 7 | <ul style="list-style-type: none"> • Remove all test equipment except the DST. • Connect any disconnected components, fuses, etc. • Using the DST clear DTC information from the ECM. • Turn the ignition OFF and wait 30 seconds. • Start the engine and operate the vehicle to full operating temperature • Observe the MIL • Observe engine performance and drivability • After operating the engine within the test parameters of DTC-686 check for any stored codes. Does the engine operate normally with no stored codes? | | System OK | Go to OBD System Check |

DTC 687-Relay Coil Short to Power

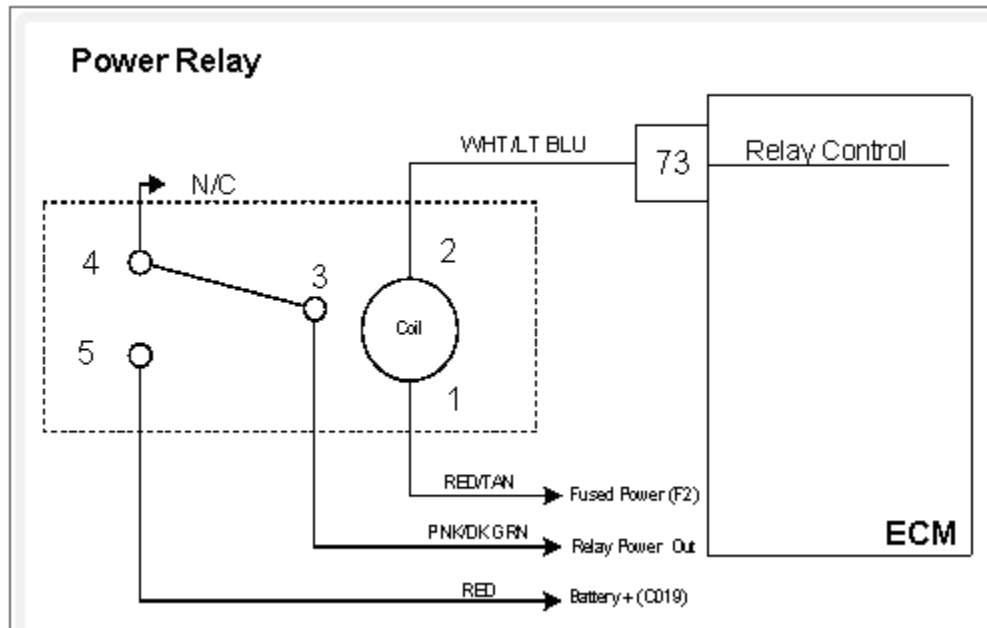

Conditions for Setting the DTC

- Power relay check
- Check Condition-Key ON
- Fault Condition-Relay coil shorted to power

Circuit Description

The power relay switches power out to various sensors, actuators and solenoids in the fuel system. This fault will set if the ECM detects a short circuit to power on the relay control output.

Diagnostic Aid

Relay coil resistance changes with temperature. The following diagnostic charts have steps to measure relay coil resistance values. When checking the resistance values be sure the relay is at a reasonable temperature, between +20 and +100 degrees F.

DTC 687-Relay Coil Short to Power

| Step | Action | Value(s) | Yes | No |
|------|--|------------------------|---|--------------------------------|
| 1 | Did you perform the On-Board (OBD) System Check? | - | Go to Step (2) | Go to OBD System Check Section |
| 2 | <ul style="list-style-type: none"> • DST connected and in the system data mode • Key OFF • Remove the power relay from the fuse block • Using a DVOM check the resistance of the relay coil between terminals 1 and 2 Is the resistance value less than 60 ohms? | | Go to Step (3) | Go to Step (4) |
| 3 | <ul style="list-style-type: none"> • Replace the power relay Is the replacement complete? | | Go to Step (9) | - |
| 4 | <ul style="list-style-type: none"> • Using a DVOM check for continuity between relay terminals 2 and 3 Do you have continuity between them? | | Go to Step (3) | Go to Step (5) |
| 5 | <ul style="list-style-type: none"> • Key OFF • Disconnect ECM wire harness connector C001 • Using a DVOM check for power between ECM pin 73 and engine ground with the key ON Do you have power? | System battery voltage | Repair the short to power. See wiring harness repair. | Go to Step (6) |
| 6 | <ul style="list-style-type: none"> • Replace the power relay Is the replacement complete? | | Go to Step (7) | - |
| 7 | <ul style="list-style-type: none"> • Remove all test equipment except the DST. • Connect any disconnected components, fuses, etc. • Using the DST clear DTC information from the ECM. • Turn the ignition OFF and wait 30 seconds. • Start the engine and operate the vehicle to full operating temperature • Observe the MIL • Observe engine performance and drivability • After operating the engine within the test parameters of DTC-687 check for any stored codes. Does DTC 687 still re-set? | | Go to Step (8) | Go to Step (9) |

| Step | Action | Value(s) | Yes | No |
|------|--|----------|----------------|------------------------|
| 8 | <ul style="list-style-type: none"> • Replace the ECM Is the replacement complete? | | Go to Step (9) | – |
| 9 | <ul style="list-style-type: none"> • Remove all test equipment except the DST. • Connect any disconnected components, fuses, etc. • Using the DST clear DTC information from the ECM. • Turn the ignition OFF and wait 30 seconds. • Start the engine and operate the vehicle to full operating temperature • Observe the MIL • Observe engine performance and drivability • After operating the engine within the test parameters of DTC-687 check for any stored codes. Does the engine operate normally with no stored codes? | | System OK | Go to OBD System Check |

DTC 1111-Fuel Rev Limit

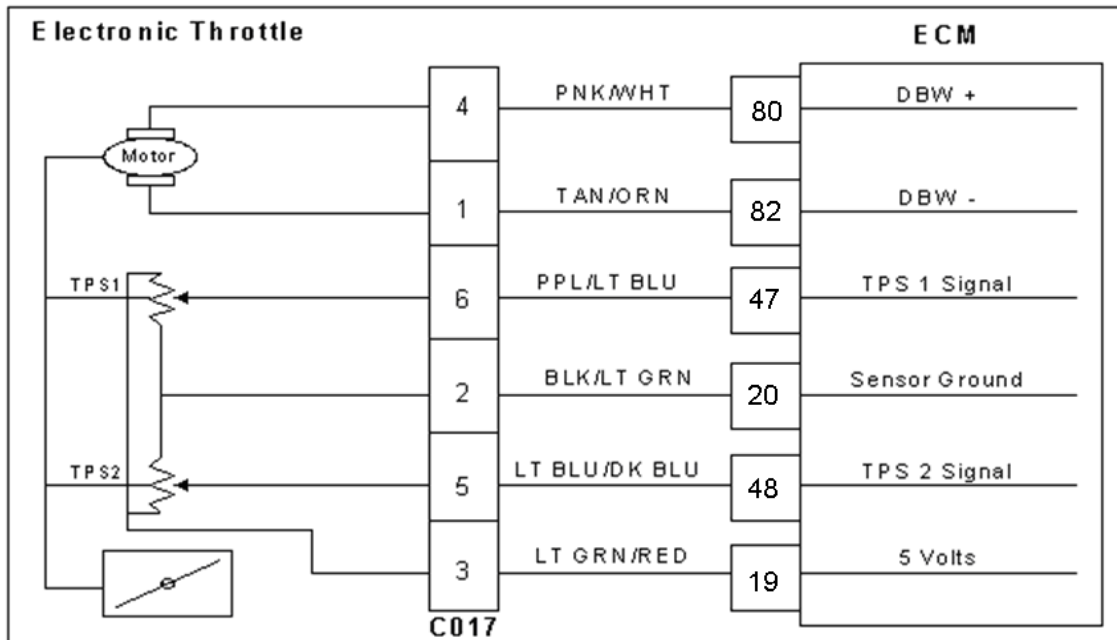

Conditions for Setting the DTC

- Fuel Rev Limit
- Check Condition-Engine Running
- Fault Condition-Engine rpm greater than 2300rpm set limit
- MIL-ON during active fault

Circuit Description

This fault will set anytime the engine rpm exceeds the specified speed settings in the calibration. This is generally set at 2300 rpms. The MIL command is ON during this active fault

Diagnostic Aid

Always check for other stored DTC codes before using the following DTC chart for this code set. Repair any existing codes starting with the lowest numerical code first.

DTC 1111-Fuel Rev Limit

| Step | Action | Value(s) | Yes | No |
|------|---|----------|----------------|--------------------------------|
| 1 | Did you perform the On-Board (OBD) System Check? | - | Go to Step (2) | Go to OBD System Check Section |
| 2 | <ul style="list-style-type: none"> • Key ON, Engine OFF • DST in Active Fault Mode Are any other DTC codes present with DTC 1111? | | Go to Step (3) | Go to Step (4) |
| 3 | <ul style="list-style-type: none"> • Diagnose and repair any other DTC codes before proceeding with this chart. Have any other DTC codes been diagnosed and repaired? | | Go to Step (4) | - |
| 4 | <ul style="list-style-type: none"> • Check the service part Number on the ECM to ensure correct calibration is in use Is the service part Number Correct? | | Go to Step (6) | Go to Step 5 |
| 5 | <ul style="list-style-type: none"> • Replace ECM with the correct service part number Is the replacement complete? | | Go to Step (9) | - |
| 6 | <ul style="list-style-type: none"> • Check the mechanical operation of the throttle Is the mechanical operation of the throttle OK? | | Go to Step (8) | Go to Step (7) |
| 7 | <ul style="list-style-type: none"> • Correct mechanical operation of the throttle. Refer to Engine & Component section Has the mechanical operation of the throttle been corrected? | | Go to Step (9) | - |
| 8 | <ul style="list-style-type: none"> • Check engine for large manifold vacuum leaks. Refer to Fuel Systems symptom diagnostics Did you find and correct the vacuum leak? | | Go to Step (9) | Go to OBD System Check Section |
| 9 | <ul style="list-style-type: none"> • Remove all test equipment except the DST. • Connect any disconnected components, fuses, etc. • Using the DST clear DTC information from the ECM. • Turn the ignition OFF and wait 30 seconds. • Start the engine and operate the vehicle to full operating temperature • Observe the MIL • Observe engine performance and drivability • After operating the engine within the test parameters of DTC-1111 check for any stored codes. Does the engine operate normally with no stored codes? | | System OK | Go to OBD System Check |

DTC 1112-Spark Rev Limit

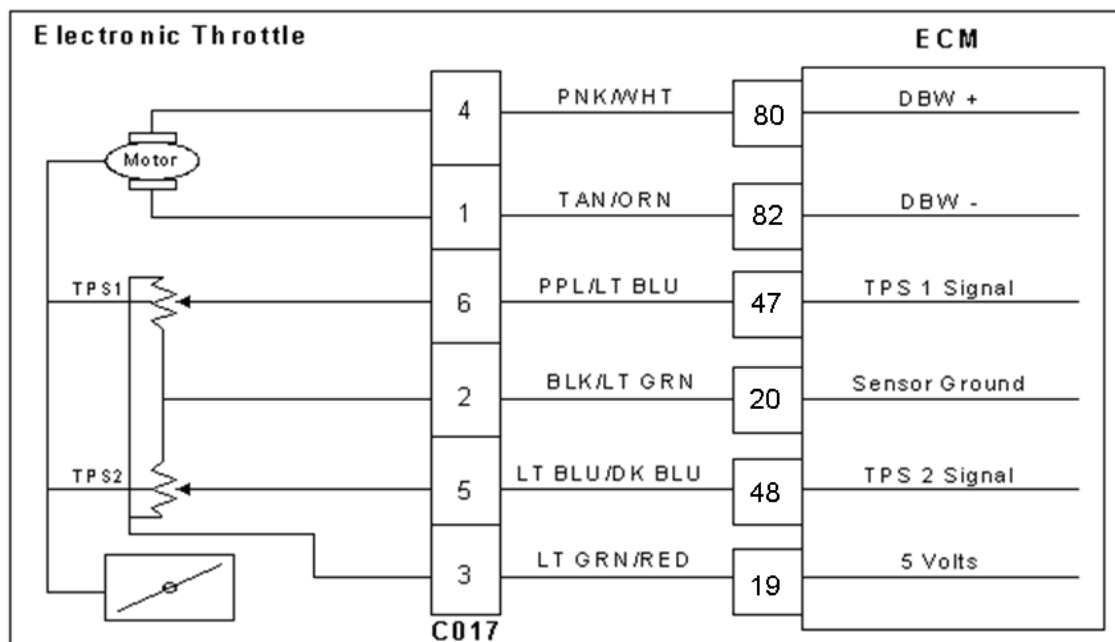

Conditions for Setting the DTC

- Spark Rev Limit
- Check Condition-Engine running
- Fault Condition-Engine rpm greater than 2325 rpm set limit
- MIL-ON during active fault
- Engine Shut Down

Circuit description

This fault will set anytime the engine rpm exceeds the specified speed settings installed in the calibration. This is set at 2325 rpms. The MIL command is ON during this active fault and the engine will shut down.

Diagnostic Aid

Always check for other stored DTC codes before using the following DTC chart for this code set. Repair any existing codes starting with the lowest numerical code first.

DTC 1112-Spark Rev Limit

| Step | Action | Value(s) | Yes | No |
|------|---|----------|----------------|--------------------------------|
| 1 | Did you perform the On-Board (OBD) System Check? | - | Go to Step (2) | Go to OBD System Check Section |
| 2 | <ul style="list-style-type: none"> • Key ON, Engine OFF • DST connected Are any other DTC codes present with DTC 1112? | | Go to Step (3) | Go to Step (4) |
| 3 | <ul style="list-style-type: none"> • Diagnose any other DTC codes before proceeding with this chart. Have any other DTC codes been diagnosed and repaired? | | Go to Step (4) | - |
| 4 | <ul style="list-style-type: none"> • Check the service part number on the ECM to ensure correct calibration is in use Is the service part number correct? | | Go to Step (6) | Go to Step 5 |
| 5 | <ul style="list-style-type: none"> • Replace ECM with correct service part number Is the replacement complete? | | Go to Step (9) | - |
| 6 | <ul style="list-style-type: none"> • Check the mechanical operation of the throttle Is the mechanical operation of the throttle OK? | | Go to Step (8) | Go to Step (7) |
| 7 | <ul style="list-style-type: none"> • Correct mechanical operation of the throttle. Refer to Engine & Component section Has the mechanical operation of the throttle been corrected? | | Go to Step (9) | - |
| 8 | <ul style="list-style-type: none"> • Check engine for large manifold vacuum leaks. Refer to Fuel Systems section Symptom Diagnostics Did you find and correct the vacuum leak? | | Go to Step (9) | Go to OBD System Check Section |
| 9 | <ul style="list-style-type: none"> • Remove all test equipment except the DST. • Connect any disconnected components, fuses, etc. • Using the DST clear DTC information from the ECM. • Turn the ignition OFF and wait 30 seconds. • Start the engine and operate the vehicle to full operating temperature • Observe the MIL • Observe engine performance and drivability • After operating the engine within the test parameters of DTC-1112 check for any stored codes. Does the engine operate normally with no stored codes? | | System OK | Go to OBD System Check |

DTC 1151-Closed Loop Multiplier High LPG

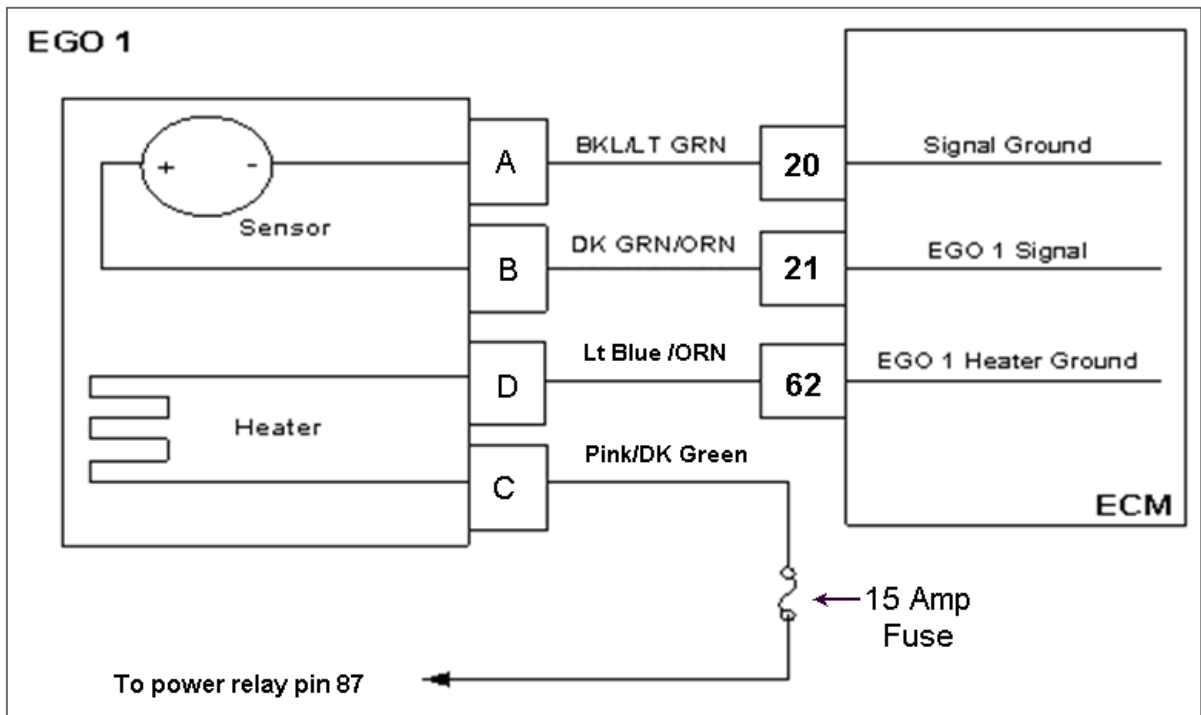

Conditions for Setting the DTC

- Heated Oxygen Sensor
- Check Condition-Engine running
- Fault Condition-Closed Loop multiplier out of range (greater than 35%)
- MIL-ON

Circuit description

The EGO sensor is used to determine if the fuel flow to the engine is correct by measuring the oxygen content in the exhaust gas. The ECM uses this information to correct the fuel flow with the Closed Loop multiplier and the adaptive multiplier. This fault sets if the Closed Loop multiplier exceeds the limits of normal operation and cannot correctly modify the fuel flow within its limits.

Diagnostic Aid

Oxygen Sensor Wire Heated Oxygen sensor wires may be mis-routed and contacting the exhaust manifold.

Vacuum Leaks Large vacuum leaks and crankcase leaks can cause a lean exhaust condition at especially at light load.

Fuel Mixer System can be lean due to faulty EPR (Electronic Pressure Regulator) or faulty fuel mixer.

Fuel Pressure Low fuel pressure, faulty fuel regulator or contaminated fuel filter can cause fuel the system to run lean

Exhaust Leaks If there is an exhaust leak, outside air can be pulled into the exhaust and past the O₂ sensor causing a false lean condition.

Fuel Quality Contaminated or spoiled fuel can cause the fuel system to be lean.

Ground Problem ECM grounds must be clean, tight and in the proper location.

DTC 1151-Closed Loop High LPG

| Step | Action | Value(s) | Yes | No |
|------|---|----------------|--|---|
| 1 | <ul style="list-style-type: none"> • Perform the On-Board (OBD) System Check? Are any other DTCs present? | | Go to Step (3) | Go to Step (2) |
| 2 | Visually and physically check the following items: <ul style="list-style-type: none"> • The air intake duct for being collapsed or restricted • The air filter for being plugged • System power fuses are good and in the proper location • The EGO 1 sensor installed securely and the wire leads not contacting the exhaust manifold or ignition wires • ECM grounds must be clean and tight. Refer to Engine Electrical Power and Ground Distribution • Fuel System Diagnostics. Refer to Fuel System Diagnostics Was a repair made? | | Go to Step (9) | Go to Step (4) |
| 3 | <ul style="list-style-type: none"> • Diagnose any other DTC codes before proceeding with this chart. Always repair existing codes starting with the lowest numerical code set first. Have any other DTC codes been detected, diagnosed and repaired? | | Go to Step (9) | Go to step (4) |
| 4 | <ul style="list-style-type: none"> • Disconnect EGO1 connector C005 • Using a DVOM check for voltage between EGO 1 connector pin B and engine ground • Key ON (CHECK MUST BE MADE WITHIN 30 SECONDS OR BEFORE POWER RELAY SHUTS DOWN) Do you have voltage? | System voltage | Go to Step (5) | Repair the open EGO power circuit as necessary. Refer to Wiring Repairs in Engine Electrical. |
| 5 | <ul style="list-style-type: none"> • Key OFF • Disconnect EGO 1 sensor wire harness connector C005 • Disconnect ECM wire harness connector C001 • Key ON • Using a high impedance DVOM check for continuity between EGO 1 connector signal pin A and engine ground Do you have continuity? | | Repair the shorted circuit as necessary. Refer to Wiring Repairs in Engine Electrical. | Go to Step (6) |

| Step | Action | Value(s) | Yes | No |
|------|---|----------|--|-----------------------------------|
| 6 | <ul style="list-style-type: none"> Using a high impedance DVOM check for continuity between EGO 1 connector signal ground pin C and EGO 1 signal pin A Do you have continuity? | | Repair the shorted circuit as necessary. Refer to Wiring Repairs in Engine Electrical. | Go to Step (7) |
| 7 | <ul style="list-style-type: none"> Using a high impedance DVOM check for continuity between EGO 1 heater ground pin D and ECM pin 62 Do you have continuity? | | Go to step (8) | Repair the open EGO heater ground |
| 8 | <ul style="list-style-type: none"> Replace EGO 1 sensor Is the replacement complete? | | Go to Step (9) | - |
| 9 | <ul style="list-style-type: none"> Remove all test equipment except the DST. Connect any disconnected components, fuses, etc. Using the DST clear DTC information from the ECM. Turn the ignition OFF and wait 30 seconds. Start the engine and operate the vehicle to full operating temperature Observe the MIL Observe engine performance and drivability After operating the engine within the test parameters of DTC-1151 check for any stored codes. Does the engine operate normally with no stored codes? | | System OK | Go to OBD System Check |

DTC 1152-Closed Loop Multiplier Low LPG

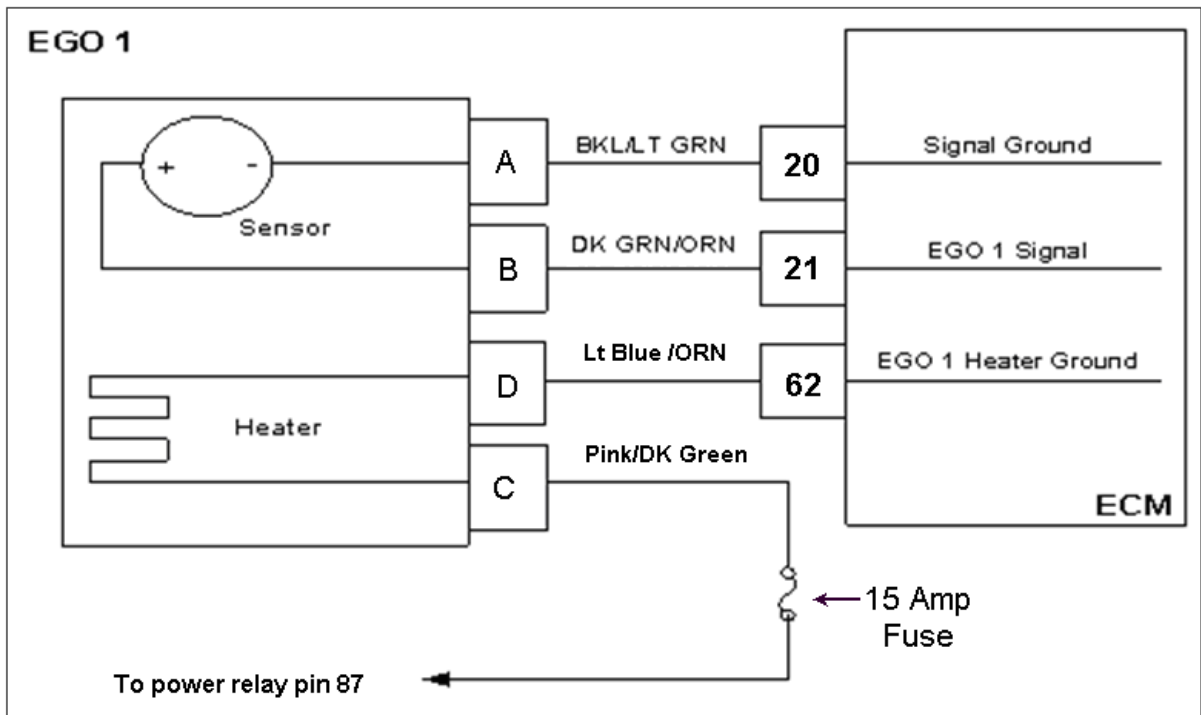

Conditions for Setting the DTC

- Heated Oxygen Sensor
- Functional Fault-Closed Loop multiplier out of range (at limit of -35%)
- MIL Disabled

Circuit Description

The EGO 1 sensor is used to determine if the fuel flow to the engine is correct by measuring the oxygen content in the exhaust gas. The ECM uses this information to correct the fuel flow with the Closed Loop multiplier and the adaptive multiplier. This fault sets if the Closed Loop multiplier exceeds the limits of normal operation. When the multiplier cannot correctly modify the fuel flow within its limits, it is limited at -35%.

Diagnostic Aid

Fuel System High secondary fuel pressure will cause the system to run rich. A worn fuel mixer, faulty EPR (Electronic Pressure Regulator) may also cause the system to run rich.

Fuel Quality A drastic variation in fuel quality (very high butane content) may cause the fuel system to run rich. Be sure that the specified HD-5 or HD-10 motor fuel grade LPG is used.

Air Filter A plugged, damaged or modified air filter may cause the system to run rich.

DTC 1152 –Closed Loop Low LPG

| Step | Action | Value(s) | Yes | No |
|------|---|----------|---|------------------------|
| 1 | <ul style="list-style-type: none"> Perform the On-Board (OBD) System Check? Are any other DTCs present? | | Go to Step (3) | Go to Step (2) |
| 2 | Visually and physically check the following items: <ul style="list-style-type: none"> The air intake duct for being collapsed or restricted The air filter for being plugged The EGO sensor installed securely and the wire leads not damaged contacting the secondary ignition wires ECM grounds for being clean and tight. Run the fuel system diagnostic checks Was a repair made? | | Go to Step (6) | Go to Step (4) |
| 3 | <ul style="list-style-type: none"> Diagnose any other DTC codes before proceeding with this chart. Have any other DTC codes been detected, diagnosed and repaired? | | Go to Step (6) | Go to Step (4) |
| 4 | <ul style="list-style-type: none"> Key OFF Disconnect EGO sensor wire harness connector Disconnect ECM wire harness connector Key ON Using a DVOM check for voltage at the EGO 1 connector C005 signal pin C and engine ground Do you have voltage? | | Repair the circuit short to voltage as necessary. Refer to wiring harness repair. | Go to Step (5) |
| 5 | <ul style="list-style-type: none"> Replace EGO sensor Is the replacement complete? | | Go to Step (6) | - |
| 6 | <ul style="list-style-type: none"> Remove all test equipment except the DST. Connect any disconnected components, fuses, etc. Using the DST clear DTC information from the ECM. Turn the ignition OFF and wait 30 seconds. Start the engine and operate the vehicle to full operating temperature Observe the MIL Observe engine performance and drivability After operating the engine within the test parameters of DTC-1152 check for any stored codes. Does the engine operate normally with no stored codes? | | System OK | Go to OBD System Check |

DTC 1153-Closed Loop Multiplier High NG

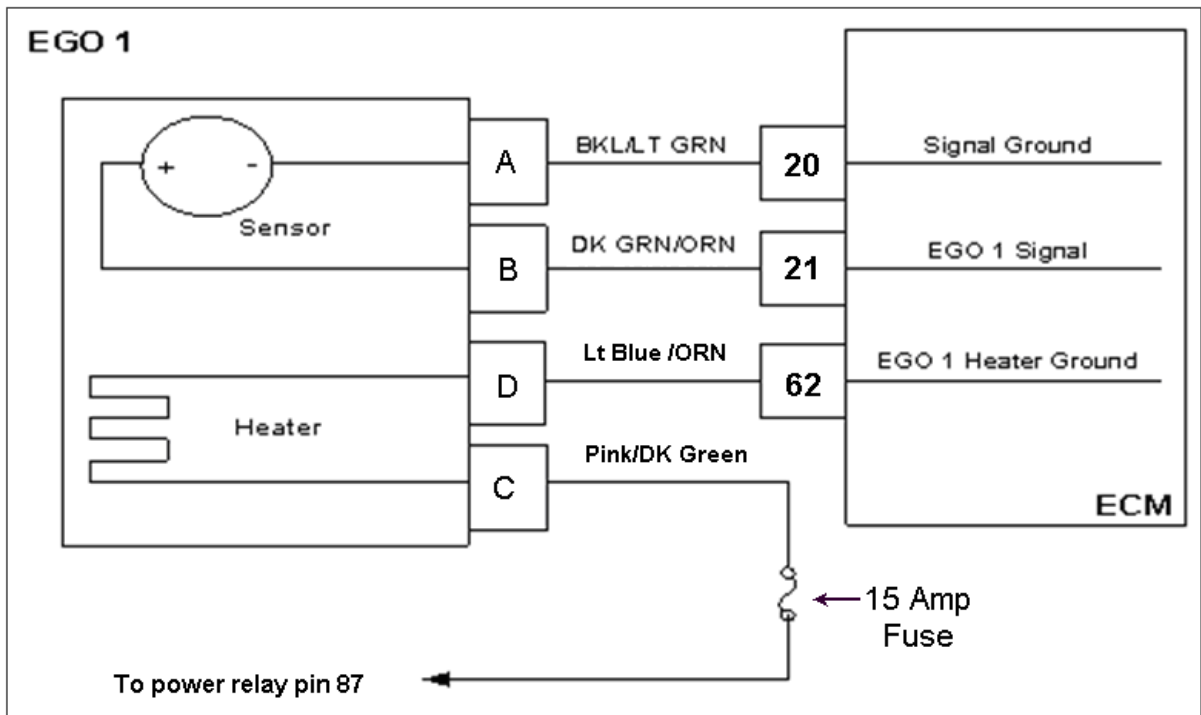

Conditions for Setting the DTC

- Heated Oxygen Sensor
- Functional Fault-Closed Loop multiplier out of range (greater than 35%)
- MIL Disabled

Circuit Description

The EGO sensor is used to determine if the fuel flow to the engine is correct by measuring the oxygen content in the exhaust gas. The ECM uses this information to correct the fuel flow with the Closed Loop multiplier and the adaptive multiplier. This fault sets if the Closed Loop multiplier exceeds the limits of normal operation and cannot correctly modify the fuel flow within its limits.

Diagnostic Aid

Oxygen Sensor Wire Heated Oxygen sensor wires may be mis-routed and contacting the exhaust manifold.

Vacuum Leaks Large vacuum leaks and crankcase leaks can cause a lean exhaust condition at especially at light load.

Fuel Mixer System can be lean due to faulty EPR (Electronic Pressure Regulator) or faulty fuel mixer.

Fuel Pressure Low fuel pressure, faulty fuel regulator or contaminated fuel filter can cause fuel the system to run lean

Exhaust Leaks If there is an exhaust leak, outside air can be pulled into the exhaust and past the O2 sensor causing a false lean condition.

Fuel Quality Contaminated or spoiled fuel can cause the fuel system to be lean.

Ground Problem ECM grounds must be clean, tight and in the proper location.

DTC 1153 –Closed Loop High NG

| Step | Action | Value(s) | Yes | No |
|------|---|----------|---|------------------------|
| 1 | <ul style="list-style-type: none"> Perform the On-Board (OBD) System Check? Are any other DTCs present? | | Go to Step (3) | Go to Step (2) |
| 2 | Visually and physically check the following items: <ul style="list-style-type: none"> The air intake duct for being collapsed or restricted The air filter for being plugged The EGO sensor installed securely and the wire leads not damaged contacting the secondary ignition wires ECM grounds for being clean and tight. Run the fuel system diagnostic checks Was a repair made? | | Go to Step (6) | Go to Step (4) |
| 3 | <ul style="list-style-type: none"> Diagnose any other DTC codes before proceeding with this chart. Have any other DTC codes been detected, diagnosed and repaired? | | Go to Step (6) | Go to Step (4) |
| 4 | <ul style="list-style-type: none"> Key OFF Disconnect EGO sensor wire harness connector Disconnect ECM wire harness connector Key ON Using a DVOM check for voltage at the EGO 1 connector C005 signal pin C and engine ground Do you have voltage? | | Repair the circuit short to voltage as necessary. Refer to wiring harness repair. | Go to Step (5) |
| 5 | <ul style="list-style-type: none"> Replace EGO sensor Is the replacement complete? | | Go to Step (6) | - |
| 6 | <ul style="list-style-type: none"> Remove all test equipment except the DST. Connect any disconnected components, fuses, etc. Using the DST clear DTC information from the ECM. Turn the ignition OFF and wait 30 seconds. Start the engine and operate the vehicle to full operating temperature Observe the MIL Observe engine performance and drivability After operating the engine within the test parameters of DTC-1153 check for any stored codes. Does the engine operate normally with no stored codes? | | System OK | Go to OBD System Check |

DTC 1154 - Closed Loop Multiplier Low NG

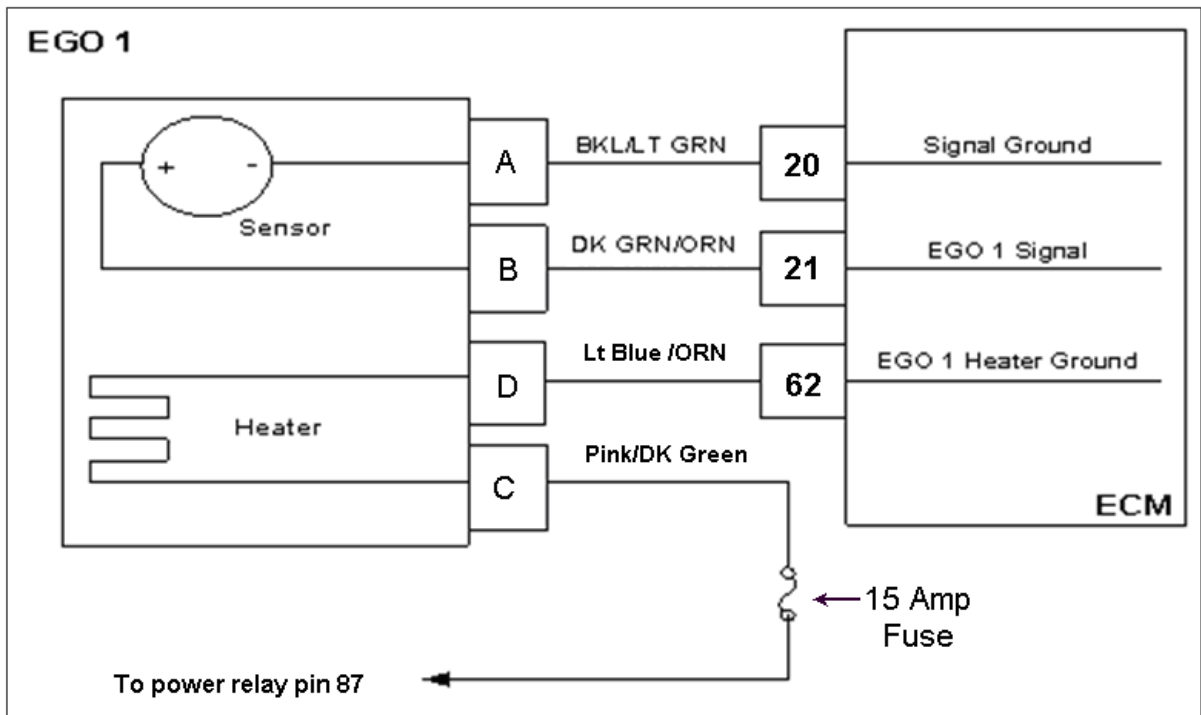

Conditions for Setting the DTC

- Heated Oxygen Sensor
- Functional Fault-Closed Loop multiplier out of range (at limit of -35%)
- MIL Disabled

Circuit Description

The EGO 1 sensor is used to determine if the fuel flow to the engine is correct by measuring the oxygen content in the exhaust gas. The ECM uses this information to correct the fuel flow with the Closed Loop multiplier and the adaptive multiplier. This fault sets if the Closed Loop multiplier exceeds the limits of normal operation. When the multiplier cannot correctly modify the fuel flow within its limits, it is limited at -35%.

Diagnostic Aid

Fuel System High secondary fuel pressure will cause the system to run rich. A worn fuel mixer, faulty EPR (Electronic Pressure Regulator) may also cause the system to run rich.

Fuel Quality A drastic variation in fuel quality (very high butane content) may cause the fuel system to run rich. Be sure that the specified HD-5 or HD-10 motor fuel grade LPG is used.

Air Filter A plugged, damaged or modified air filter may cause the system to run rich.

DTC 1154 - Closed Loop Multiplier Low NG

| Step | Action | Value(s) | Yes | No |
|------|---|----------|---|------------------------|
| 1 | <ul style="list-style-type: none"> Perform the On-Board (OBD) System Check? Are any other DTCs present? | | Go to Step (3) | Go to Step (2) |
| 2 | Visually and physically check the following items: <ul style="list-style-type: none"> The air intake duct for being collapsed or restricted The air filter for being plugged The EGO sensor installed securely and the wire leads not damaged contacting the secondary ignition wires ECM grounds for being clean and tight. Run the fuel system diagnostic checks Was a repair made? | | Go to Step (6) | Go to Step (4) |
| 3 | <ul style="list-style-type: none"> Diagnose any other DTC codes before proceeding with this chart. Have any other DTC codes been detected, diagnosed and repaired? | | Go to Step (6) | Go to Step (4) |
| 4 | <ul style="list-style-type: none"> Key OFF Disconnect EGO sensor wire harness connector Disconnect ECM wire harness connector Key ON Using a DVOM check for voltage at the EGO 1 connector C005 signal pin C and engine ground Do you have voltage? | | Repair the circuit short to voltage as necessary. Refer to wiring harness repair. | Go to Step (5) |
| 5 | <ul style="list-style-type: none"> Replace EGO sensor Is the replacement complete? | | Go to Step (6) | - |
| 6 | <ul style="list-style-type: none"> Remove all test equipment except the DST. Connect any disconnected components, fuses, etc. Using the DST clear DTC information from the ECM. Turn the ignition OFF and wait 30 seconds. Start the engine and operate the vehicle to full operating temperature Observe the MIL Observe engine performance and drivability After operating the engine within the test parameters of DTC-1154 check for any stored codes. Does the engine operate normally with no stored codes? | | System OK | Go to OBD System Check |

DTC 1161-Adaptive Learn High LPG

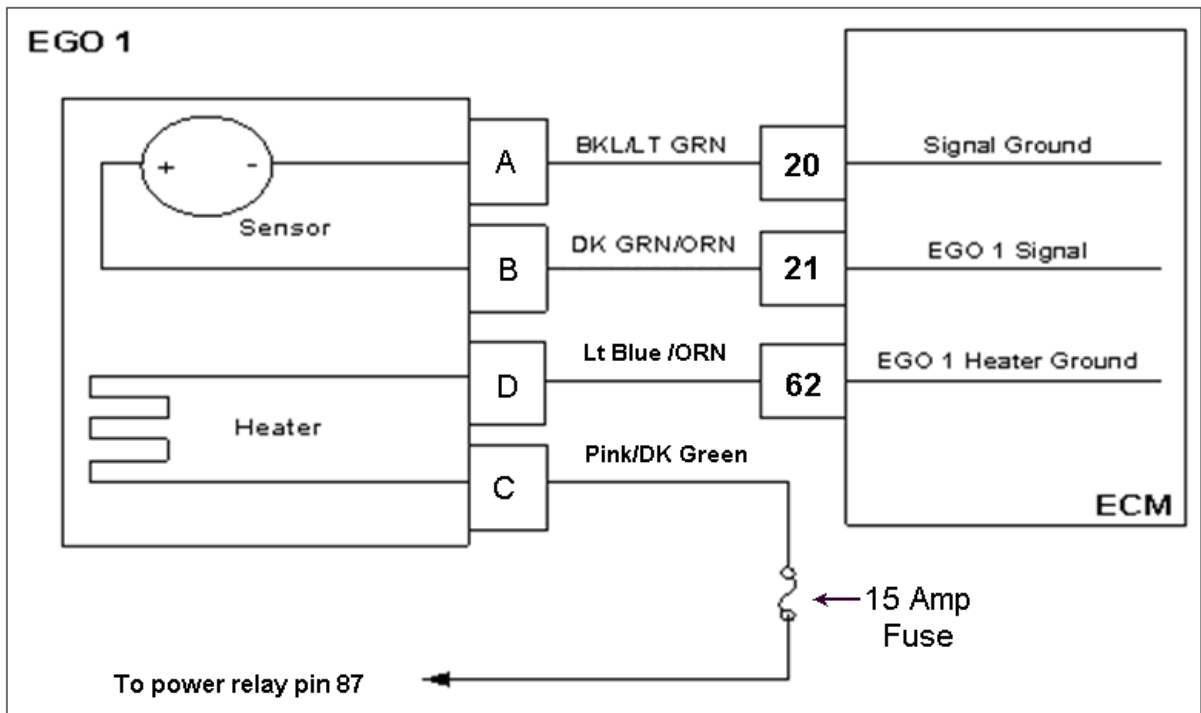

Conditions for Setting the DTC

- Heated Oxygen Sensor
- Check Condition-Engine Running
- Fault Condition-Adaptive multiplier out of range greater than 30%
- MIL-ON

Circuit Description

The EGO 1 sensor is used to determine if the fuel flow to the engine is correct by measuring the oxygen content in the exhaust gas. The ECM uses this information to correct the fuel flow with the Closed Loop multiplier and Adaptive multiplier. This fault will set if the adaptive multiplier exceeds the limits of normal operation. Always run the fuel system diagnostic checks before using the following diagnostic chat.

Diagnostic Aid

Oxygen Sensor Wire Heated Oxygen sensor wires may be mis-routed and contacting the exhaust manifold.

Vacuum Leaks Large vacuum leaks and crankcase leaks can cause a lean exhaust condition at especially at light load.

Fuel Mixer System can be lean due to faulty EPR (Electronic Pressure Regulator) or faulty fuel mixer.

Fuel Pressure Low fuel pressure, faulty fuel regulator or contaminated fuel filter can cause fuel the system to run lean

Exhaust Leaks If there is an exhaust leak, outside air can be pulled into the exhaust and past the O2 sensor causing a false lean condition.

Fuel Quality Contaminated or spoiled fuel can cause the fuel system to be lean.

Ground Problem ECM grounds must be clean, tight and in the proper location.

DTC 1161 Adaptive Learn High LPG

| Step | Action | Value(s) | Yes | No |
|------|---|----------------|--|---|
| 1 | <ul style="list-style-type: none"> Perform the On-Board (OBD) System Check? Are any other DTCs present? | | Go to Step (3) | Go to Step (2) |
| 2 | Visually and physically check the following items: <ul style="list-style-type: none"> The air intake duct for being collapsed or restricted The air filter for being plugged System power fuses are good and in the proper location The EGO 1 sensor installed securely and the wire leads not contacting the exhaust manifold or ignition wires ECM grounds must be clean and tight. Refer to Engine Electrical Power and Ground Distribution Fuel System Diagnostics. Refer to Fuel System Diagnostics Was a repair made? | | Go to Step (9) | Go to Step (4) |
| 3 | <ul style="list-style-type: none"> Diagnose any other DTC codes before proceeding with this chart. Always repair existing codes starting with the lowest numerical code set first. Have any other DTC codes been detected, diagnosed and repaired? | | Go to Step (9) | Go to Step (4) |
| 4 | <ul style="list-style-type: none"> Disconnect EGO1 connector C005 Using a DVOM check for voltage between EGO 1 connector pin B and engine ground Key ON (CHECK MUST BE MADE WITHIN 30 SECONDS OR BEFORE POWER RELAY SHUTS DOWN) Do you have voltage? | System voltage | Go to Step (5) | Repair the open EGO power circuit as necessary. Refer to Wiring Repairs in Engine Electrical. |
| 5 | <ul style="list-style-type: none"> Key OFF Disconnect EGO 1 sensor wire harness connector C005 Disconnect ECM wire harness connector C001 Key ON Using a high impedance DVOM check for continuity between EGO 1 connector signal pin A and engine ground Do you have continuity? | | Repair the shorted circuit as necessary. Refer to Wiring Repairs in Engine Electrical. | Go to Step (6) |

| Step | Action | Value(s) | Yes | No |
|------|---|----------|--|-----------------------------------|
| 6 | <ul style="list-style-type: none"> Using a high impedance DVOM check for continuity between EGO 1 connector signal ground pin C and EGO 1 signal pin A Do you have continuity? | | Repair the shorted circuit as necessary. Refer to Wiring Repairs in Engine Electrical. | Go to Step (7) |
| 7 | <ul style="list-style-type: none"> Using a high impedance DVOM check for continuity between EGO 1 heater ground pin D and ECM pin 62 Do you have continuity? | | Go to Step (8) | Repair the open EGO heater ground |
| 8 | <ul style="list-style-type: none"> Replace EGO 1 sensor Is the replacement complete? | | Go to Step (9) | - |
| 9 | <ul style="list-style-type: none"> Remove all test equipment except the DST. Connect any disconnected components, fuses, etc. Using the DST clear DTC information from the ECM. Turn the ignition OFF and wait 30 seconds. Start the engine and operate the vehicle to full operating temperature Observe the MIL Observe engine performance and drivability After operating the engine within the test parameters of DTC-1161 check for any stored codes. Does the engine operate normally with no stored codes? | | System OK | Go to OBD System Check |

DTC 1162-Adaptive Learn Low (LPG)

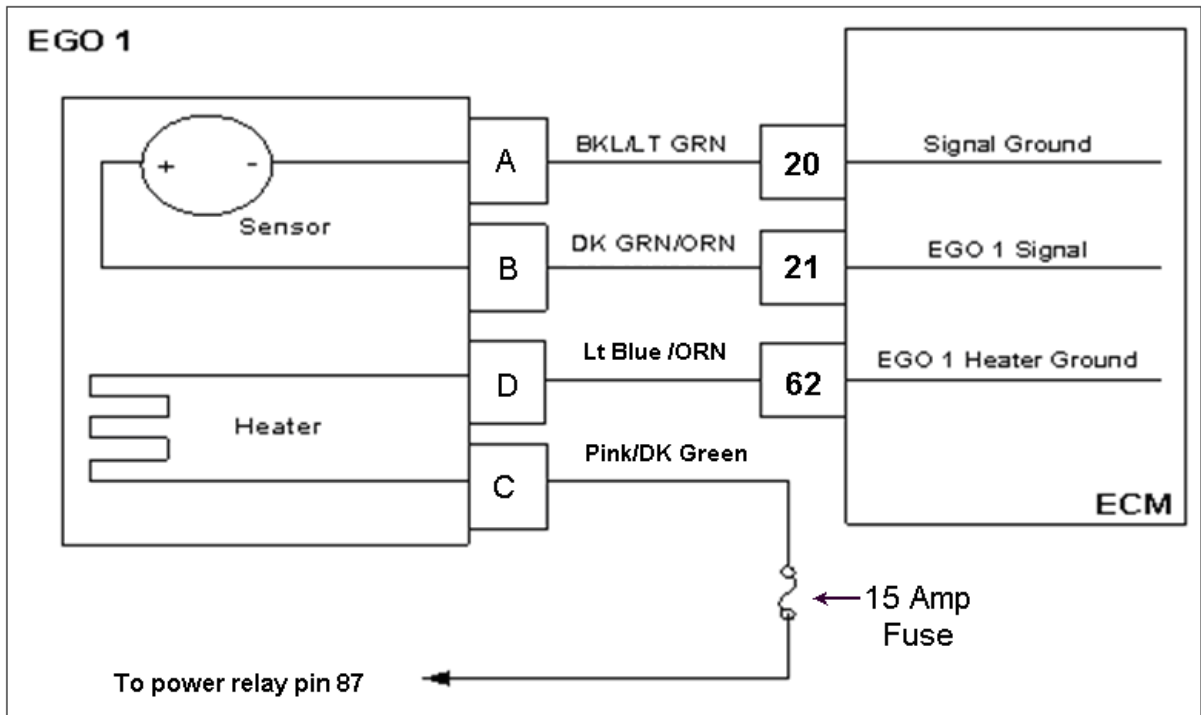

Conditions for Setting the DTC

- Heated Oxygen Sensor
- Check Condition-Engine running
- Fault Condition-Adaptive multiplier out of range greater than -30%
- MIL-ON

Circuit Description

The EGO1 sensor is used to determine if the fuel flow to the engine is correct by measuring the oxygen content in the exhaust gas. The ECM uses this information to correct the fuel flow with the Closed Loop multiplier and Adaptive multiplier. This fault will set if the adaptive multiplier exceeds the limits of normal operation. Always run the fuel system diagnostics before using the following diagnostic chart.

Diagnostic Aid

Fuel System High secondary fuel pressure will cause the system to run rich. A worn fuel mixer, faulty EPR (Electronic Pressure Regulator) may also cause the system to run rich.

Fuel Quality A drastic variation in fuel quality (very high butane content) may cause the fuel system to run rich. Be sure that the specified HD-5 or HD-10 motor fuel grade propane is used.

Air Filter A plugged, damaged or modified air filter may cause the system to run rich.

DTC 1162-Adaptive Learn Low LPG

| Step | Action | Value(s) | Yes | No |
|------|---|----------|--|------------------------|
| 1 | <ul style="list-style-type: none"> Perform the On-Board (OBD) System Check? Are any other DTCs present? | | Go to Step (3) | Go to Step (2) |
| 2 | Visually and physically check the following items: <ul style="list-style-type: none"> The air intake duct for being collapsed or restricted The air filter for being plugged The EGO sensor is installed securely and the wire leads not damaged or contacting the secondary ignition wires ECM grounds for being clean and tight. Fuel system diagnostic checks Was a repair made? | | Go to Step (6) | Go to Step (4) |
| 3 | <ul style="list-style-type: none"> Diagnose any other DTC codes before proceeding with this chart. Have any other DTC codes been detected, diagnosed and repaired? | | Go to Step (6) | Go to Step (4) |
| 4 | <ul style="list-style-type: none"> Key OFF Disconnect EGO sensor wire harness connector C005 Disconnect ECM wire harness connector C001 Key ON Using a DVOM check for voltage at EGO 1 connector signal pin A and engine ground Do you have voltage? | | Repair the circuit as necessary. Refer to Wiring Repairs in Engine Electrical. | Go to Step (5) |
| 5 | <ul style="list-style-type: none"> Replace EGO sensor Is the replacement complete? | | Go to Step (6) | - |
| 6 | <ul style="list-style-type: none"> Remove all test equipment except the DST. Connect any disconnected components, fuses, etc. Using the DST clear DTC information from the ECM. Turn the ignition OFF and wait 30 seconds. Start the engine and operate the vehicle to full operating temperature Observe the MIL Observe engine performance and drivability After operating the engine within the test parameters of DTC-1162 check for any stored codes. Does the engine operate normally with no stored codes? | | System OK | Go to OBD System Check |

DTC 1163-Adaptive Learn High NG

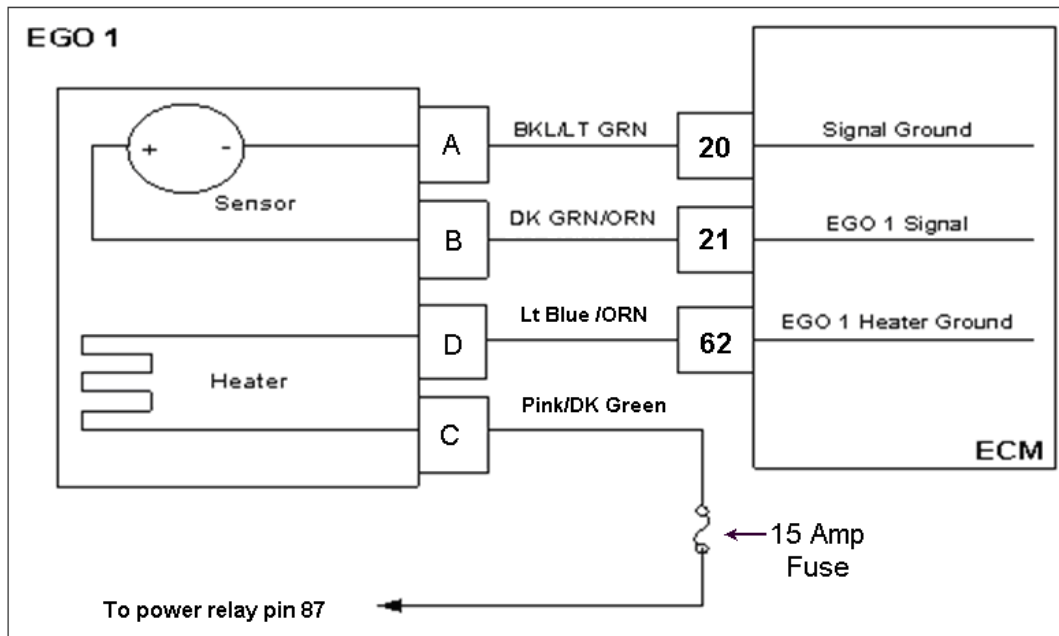

Conditions for Setting the DTC

- Heated Oxygen Sensor
- Check Condition-Engine Running
- Fault Condition-Adaptive multiplier out of range greater than 30%
- MIL-ON

Circuit Description

The EGO 1 sensor is used to determine if the fuel flow to the engine is correct by measuring the oxygen content in the exhaust gas. The ECM uses this information to correct the fuel flow with the Closed Loop multiplier and Adaptive multiplier. This fault will set if the adaptive multiplier exceeds the limits of normal operation. Always run the fuel system diagnostic checks before using the following diagnostic chat.

Diagnostic Aid

Oxygen Sensor Wire Heated Oxygen sensor wires may be mis-routed and contacting the exhaust manifold.

Vacuum Leaks Large vacuum leaks and crankcase leaks can cause a lean exhaust condition at especially at light load.

Fuel Mixer System can be lean due to faulty EPR (Electronic Pressure Regulator) or faulty fuel mixer.

Fuel Pressure Low fuel pressure, faulty fuel regulator or contaminated fuel filter can cause fuel the system to run lean

Exhaust Leaks If there is an exhaust leak, outside air can be pulled into the exhaust and past the O₂ sensor causing a false lean condition.

Fuel Quality Contaminated or spoiled fuel can cause the fuel system to be lean.

Ground Problem ECM grounds must be clean, tight and in the proper location.

DTC 1161 Adaptive Learn High LPG

| Step | Action | Value(s) | Yes | No |
|------|---|----------------|--|---|
| 1 | <ul style="list-style-type: none"> Perform the On-Board (OBD) System Check? Are any other DTCs present? | | Go to Step (3) | Go to Step (2) |
| 2 | Visually and physically check the following items: <ul style="list-style-type: none"> The air intake duct for being collapsed or restricted The air filter for being plugged System power fuses are good and in the proper location The EGO 1 sensor installed securely and the wire leads not contacting the exhaust manifold or ignition wires ECM grounds must be clean and tight. Refer to Engine Electrical Power and Ground Distribution Fuel System Diagnostics. Refer to Fuel System Diagnostics Was a repair made? | | Go to Step (9) | Go to Step (4) |
| 3 | <ul style="list-style-type: none"> Diagnose any other DTC codes before proceeding with this chart. Always repair existing codes starting with the lowest numerical code set first. Have any other DTC codes been detected, diagnosed and repaired? | | Go to Step (9) | Go to Step (4) |
| 4 | <ul style="list-style-type: none"> Disconnect EGO1 connector C005 Using a DVOM check for voltage between EGO 1 connector pin B and engine ground Key ON (CHECK MUST BE MADE WITHIN 30 SECONDS OR BEFORE POWER RELAY SHUTS DOWN) Do you have voltage? | System voltage | Go to Step (5) | Repair the open EGO power circuit as necessary. Refer to Wiring Repairs in Engine Electrical. |
| 5 | <ul style="list-style-type: none"> Key OFF Disconnect EGO 1 sensor wire harness connector C005 Disconnect ECM wire harness connector C001 Key ON Using a high impedance DVOM check for continuity between EGO 1 connector signal pin A and engine ground Do you have continuity? | | Repair the shorted circuit as necessary. Refer to Wiring Repairs in Engine Electrical. | Go to Step (6) |

| Step | Action | Value(s) | Yes | No |
|------|---|----------|--|-----------------------------------|
| 6 | <ul style="list-style-type: none"> Using a high impedance DVOM check for continuity between EGO 1 connector signal ground pin C and EGO 1 signal pin A Do you have continuity? | | Repair the shorted circuit as necessary. Refer to Wiring Repairs in Engine Electrical. | Go to Step (7) |
| 7 | <ul style="list-style-type: none"> Using a high impedance DVOM check for continuity between EGO 1 heater ground pin D and ECM pin 62 Do you have continuity? | | Go to Step (8) | Repair the open EGO heater ground |
| 8 | <ul style="list-style-type: none"> Replace EGO 1 sensor Is the replacement complete? | | Go to Step (9) | - |
| 9 | <ul style="list-style-type: none"> Remove all test equipment except the DST. Connect any disconnected components, fuses, etc. Using the DST clear DTC information from the ECM. Turn the ignition OFF and wait 30 seconds. Start the engine and operate the vehicle to full operating temperature Observe the MIL Observe engine performance and drivability After operating the engine within the test parameters of DTC-1161 check for any stored codes. Does the engine operate normally with no stored codes? | | System OK | Go to OBD System Check |

DTC 1164-Adaptive Learn Low NG

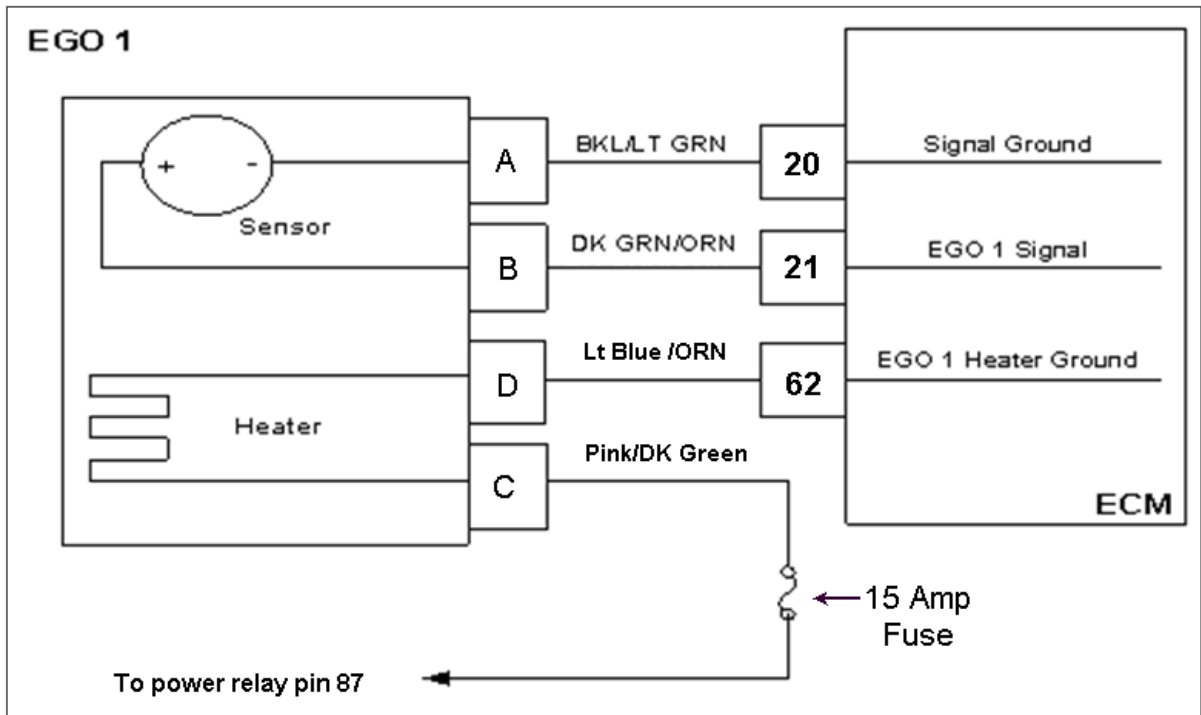

Conditions for Setting the DTC

- Heated Oxygen Sensor
- Check Condition-Engine running
- Fault Condition-Adaptive multiplier out of range greater than -30%
- MIL-ON

Circuit Description

The EGO1 sensor is used to determine if the fuel flow to the engine is correct by measuring the oxygen content in the exhaust gas. The ECM uses this information to correct the fuel flow with the Closed Loop multiplier and Adaptive multiplier. This fault will set if the adaptive multiplier exceeds the limits of normal operation. Always run the fuel system diagnostics before using the following diagnostic chart.

Diagnostic Aid

Fuel System High secondary fuel pressure will cause the system to run rich. A worn fuel mixer, faulty EPR (Electronic Pressure Regulator) may also cause the system to run rich.

Fuel Quality A drastic variation in fuel quality (very high butane content) may cause the fuel system to run rich. Be sure that the specified HD-5 or HD-10 fuel grade propane is used.

Air Filter A plugged, damaged or modified air filter may cause the system to run rich.

DTC 1164-Adaptive Learn Low NG

| Step | Action | Value(s) | Yes | No |
|------|---|----------|--|------------------------|
| 1 | <ul style="list-style-type: none"> Perform the On-Board (OBD) System Check? Are any other DTCs present? | | Go to Step (3) | Go to Step (2) |
| 2 | Visually and physically check the following items: <ul style="list-style-type: none"> The air intake duct for being collapsed or restricted The air filter for being plugged The EGO sensor is installed securely and the wire leads not damaged or contacting the secondary ignition wires ECM grounds for being clean and tight. Fuel system diagnostic checks Was a repair made? | | Go to Step (6) | Go to Step (4) |
| 3 | <ul style="list-style-type: none"> Diagnose any other DTC codes before proceeding with this chart. Have any other DTC codes been detected, diagnosed and repaired? | | Go to Step (6) | Go to Step (4) |
| 4 | <ul style="list-style-type: none"> Key OFF Disconnect EGO sensor wire harness connector C005 Disconnect ECM wire harness connector C001 Key ON Using a DVOM check for voltage at EGO 1 connector signal pin A and engine ground Do you have voltage? | | Repair the circuit as necessary. Refer to Wiring Repairs in Engine Electrical. | Go to Step (5) |
| 5 | <ul style="list-style-type: none"> Replace EGO sensor Is the replacement complete? | | Go to Step (6) | - |
| 6 | <ul style="list-style-type: none"> Remove all test equipment except the DST. Connect any disconnected components, fuses, etc. Using the DST clear DTC information from the ECM. Turn the ignition OFF and wait 30 seconds. Start the engine and operate the vehicle to full operating temperature Observe the MIL Observe engine performance and drivability After operating the engine within the test parameters of DTC-1162 check for any stored codes. Does the engine operate normally with no stored codes? | | System OK | Go to OBD System Check |

DTC1171-EPR Pressure Higher Than Expected

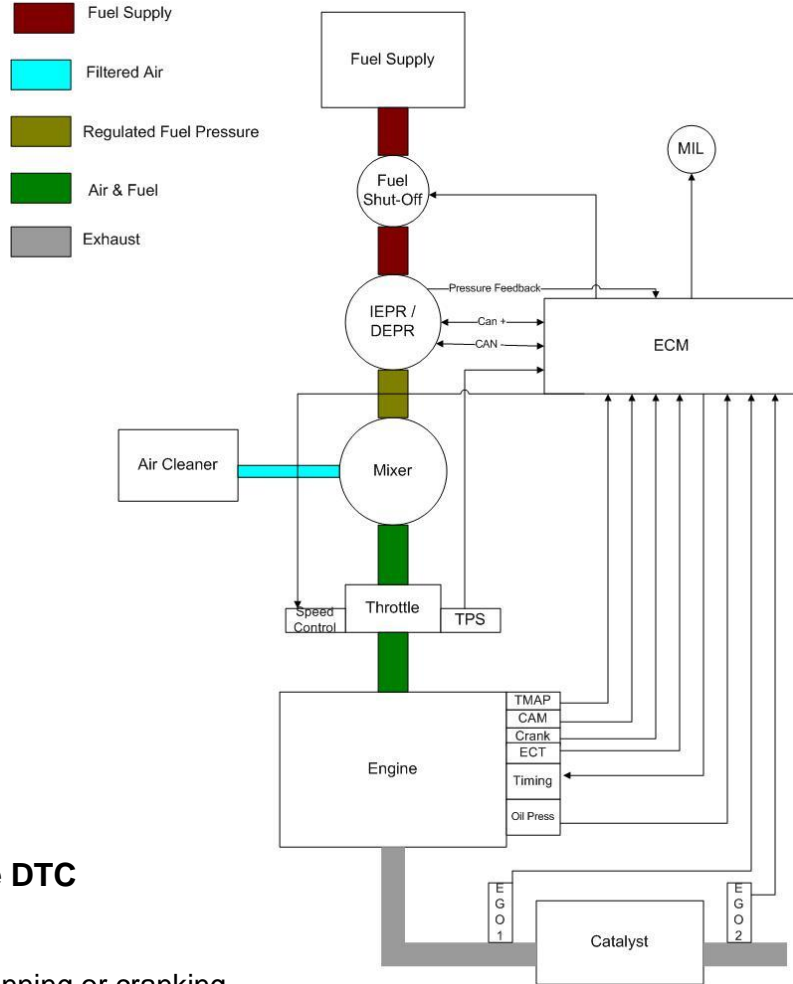

Conditions for Setting the DTC

- EPR delivery pressure
- Check condition-Engine running or cranking
- MIL-ON during active fault
- Fault condition-EPR actual pressure greater than 1.5 inches above commanded pressure
- Adaptive disabled
- Engine shutdown will occur

Circuit Description

The EPR (Electronic Pressure Regulator) unit measures and controls the amount of fuel that is able to pass to the fuel mixer. This code will set in the event the actual pressure is 1.5 inches water pressure higher than the actual commanded pressure. Adaptive learn is disabled and the MIL command is ON during this fault. The engine will shutdown if this fault occurs.

Diagnostic Aid

Always run the fuel system diagnostic pressure check before proceeding with the following diagnostic chart. High secondary fuel pressure due to a worn or damaged primary or secondary seat may cause this fault to set

DTC 1171-EPR Pressure Higher Than Expected

| Step | Action | Value(s) | Yes | No |
|------|--|----------|--|---|
| 1 | Did you perform the On-Board (OBD) System Check? | - | Go to Step (2) | Go to OBD System Check Section |
| 2 | Did you run the fuel pressure diagnostic test in the fuel system diagnostic section with no problems found? | | Go to Step (4) | Go to Step (3) |
| 3 | <ul style="list-style-type: none"> • Run the EPR pressure test in the fuel system diagnostic section Did the EPR pass the fuel pressure test specifications? | | Go to Step (4) | Follow the EPR service recommendations from the fuel pressure test chart. |
| 4 | <ul style="list-style-type: none"> • Inspect the EPR electrical connector pins C018 for damage, corrosion or contamination. Did you find a problem? | | Repair the circuit as necessary. Refer to wire harness repair section. | Go to Step (5) |
| 5 | <ul style="list-style-type: none"> • Replace or repair the EPR Is the replacement complete? | | Go to Step (6) | - |
| 6 | <ul style="list-style-type: none"> • Remove all test equipment except the DST. • Connect any disconnected components, fuses, etc. • Using the DST clear DTC information from the ECM. • Turn the ignition OFF and wait 30 seconds. • Start the engine and operate the vehicle to full operating temperature • Observe the MIL • Observe engine performance and drivability • After operating the engine within the test parameters of DTC1171 check for any stored codes. Does the engine operate normally with no stored codes? | | System OK | Go to OBD System Check |

DTC1172-EPR Pressure Lower Than Expected

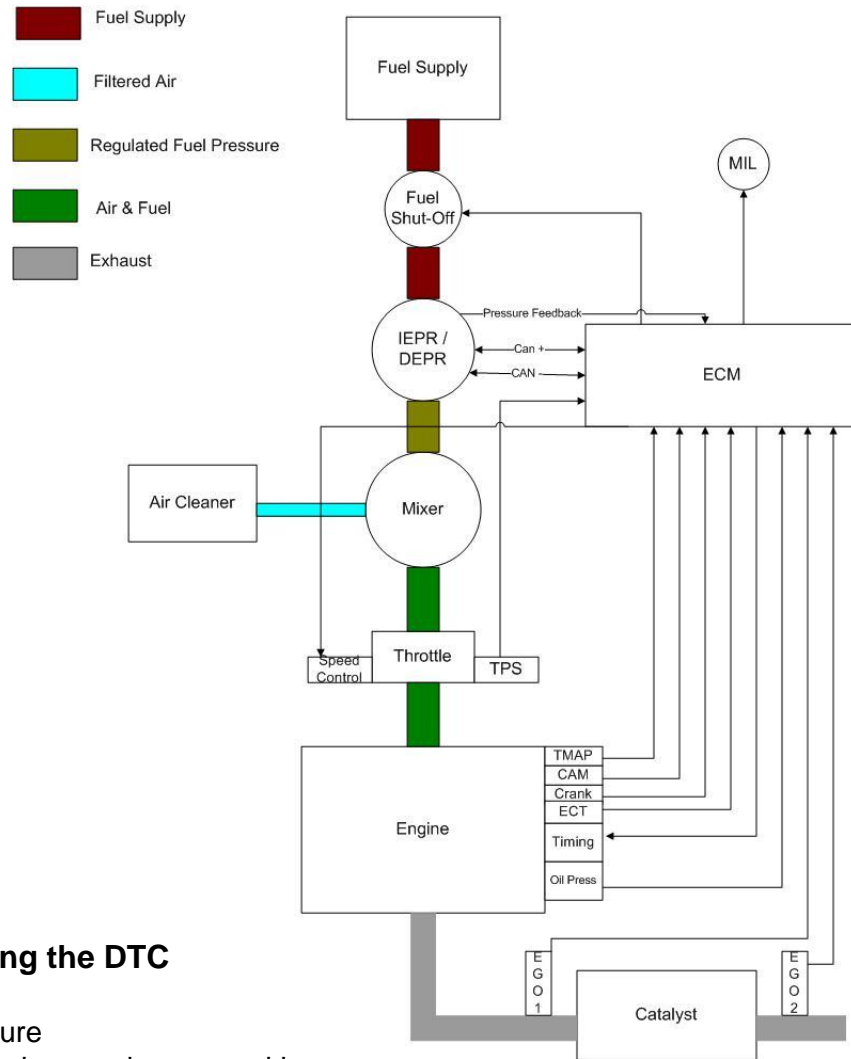

Conditions for Setting the DTC

- EPR delivery pressure
- Check condition-Engine running or cranking
- MIL-ON during active fault
- Fault condition-EPR actual pressure less than 1.5 inches below commanded pressure
- Adaptive disabled
- Engine shutdown will occur

Circuit Description

The EPR (Electronic Pressure Regulator) unit measures and controls the amount of fuel that is able to pass to the fuel mixer. This code will set in the event the actual pressure is 1.0 inches water pressure lower than the actual commanded pressure. Adaptive is disabled and the MIL command is ON during this fault. Engine will shutdown if this fault occurs.

Diagnostic Aid

Always run the fuel system diagnostic pressure check before proceeding with the following diagnostic chart. Low secondary fuel pressure due to a fuel restriction or faulty regulator may cause this fault.

DTC 1172-EPR Pressure Lower Than Expected

| Step | Action | Value(s) | Yes | No |
|------|--|----------|--|---|
| 1 | Did you perform the On-Board (OBD) System Check? | - | Go to Step (2) | Go to OBD System Check Section |
| 2 | Did you run the fuel pressure diagnostic test in the fuel system diagnostic section with no problems found? | | Go to Step (4) | Go to Step (3) |
| 3 | <ul style="list-style-type: none"> • Run the EPR pressure test in the fuel system diagnostic section Did the EPR pass the fuel pressure test specifications? | | Go to Step (4) | Follow the EPR service recommendations from the fuel pressure test chart. |
| 4 | <ul style="list-style-type: none"> • Inspect the EPR electrical connector C018 for damage, corrosion or contamination. Did you find a problem? | | Repair the circuit as necessary. Refer to wire harness repair section. | Go to Step (5) |
| 5 | <ul style="list-style-type: none"> • Replace or repair the EPR Is the replacement complete? | | Go to Step (6) | - |
| 6 | <ul style="list-style-type: none"> • Remove all test equipment except the DST. • Connect any disconnected components, fuses, etc. • Using the DST clear DTC information from the ECM. • Turn the ignition OFF and wait 30 seconds. • Start the engine and operate the vehicle to full operating temperature • Observe the MIL • Observe engine performance and drivability • After operating the engine within the test parameters of DTC1172 check for any stored codes. Does the engine operate normally with no stored codes? | | System OK | Go to OBD System Check |

DTC 1612-RTI 1 Loss

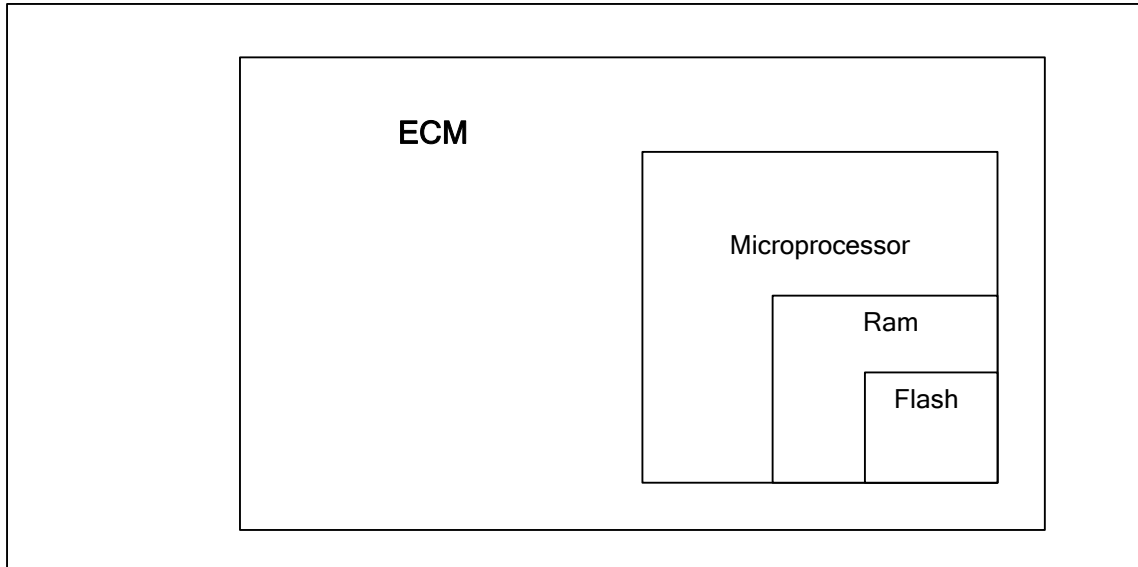

Conditions for Setting the DTC

- Engine Control Module
- Check Condition-Key on
- Fault Condition-Internal microprocessor error
- MIL-ON
- Adaptive-Disabled for the remainder of the key-ON cycle
- Engine shutdown will occur

Circuit Description

The ECM has several internal checks that must be satisfied each time an instruction is executed. Several different things can happen within the microprocessor that will cause this fault. The ECM will attempt to reset itself in the event this fault is set. The MIL command is on and will remain on until the code is cleared using the DST. The engine will shutdown if this code occurs.

DTC 1612-RT 1 Loss

| Step | Action | Value(s) | Yes | No |
|------|---|----------|----------------|---|
| 1 | Did you perform the On-Board (OBD) System Check? | - | Go to Step (2) | Go to OBD System Check Section |
| 2 | <ul style="list-style-type: none"> • Key ON, Engine Running • DST (Diagnostic Scan Tool) connected in System Data Mode • Clear system fault code Does DTC 1612 reset with the engine idling? | | Go to Step (3) | Intermittent problem Go to Intermittent section |
| 3 | <ul style="list-style-type: none"> • Check ECM power and ground circuits Did the power and ground circuits check OK? | | Go to Step (4) | Repair the circuit as necessary. Refer to Wiring Repairs in Engine Electrical. |
| 4 | <ul style="list-style-type: none"> • Replace ECM Is the replacement complete? | | Go to Step (5) | - |
| 5 | <ul style="list-style-type: none"> • Remove all test equipment except the DST. • Connect any disconnected components, fuses, etc. • Using the DST clear DTC information from the ECM. • Turn the ignition OFF and wait 30 seconds. • Start the engine and operate the vehicle to full operating temperature • Observe the MIL • Observe engine performance and drivability • After operating the engine within the test parameters of DTC-1612 check for any stored codes. Does the engine operate normally with no stored codes? | | System OK | Go to OBD System Check |

DTC 1613-RTI 2 Loss

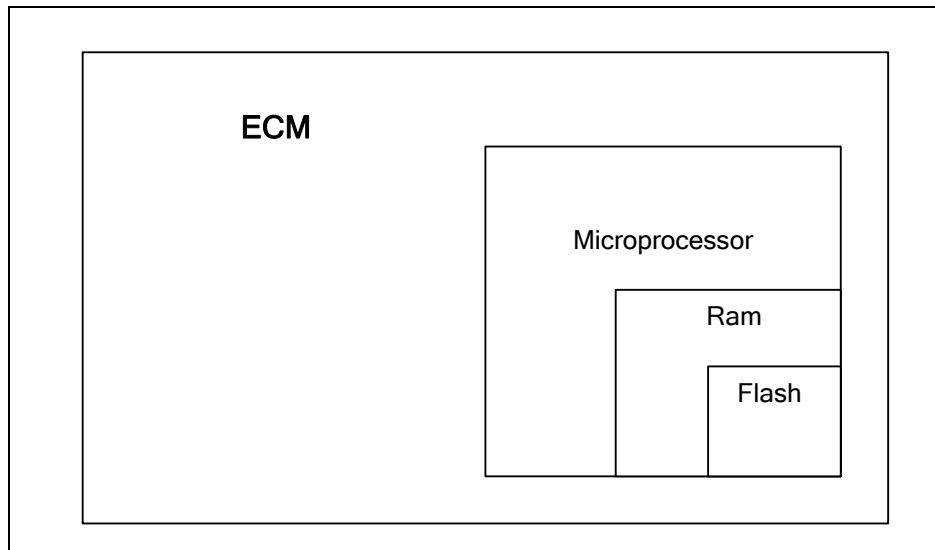

Conditions for Setting the DTC

- Engine Control Module
- Check Condition-Key on
- Fault Condition-Internal microprocessor error
- MIL-ON
- Adaptive-Disabled for the remainder of the key-ON cycle
- Engine shutdown will occur

Circuit Description

The ECM has several internal checks that must be satisfied each time an instruction is executed. Several different things can happen within the microprocessor that will cause this fault. The ECM will attempt to reset itself in the event this fault is set. The MIL command is on and will remain on until the code is cleared using the DST. The engine will shut down if this code occurs.

DTC 1613-RTI 2 Loss

| Step | Action | Value(s) | Yes | No |
|------|---|----------|----------------|---|
| 1 | Did you perform the On-Board (OBD) System Check? | - | Go to Step (2) | Go to OBD System Check Section |
| 2 | <ul style="list-style-type: none"> • Key ON, Engine Running • DST (Diagnostic Scan Tool) connected in System Data Mode • Clear system fault code Does DTC 1613 reset with the engine idling? | | Go to Step (3) | Intermittent problem Go to Intermittent section |
| 3 | <ul style="list-style-type: none"> • Check ECM power and ground circuits Did the power and ground circuits check OK? | | Go to Step (4) | Repair the circuit as necessary. Refer to Wiring Repairs in Engine Electrical. |
| 4 | <ul style="list-style-type: none"> • Replace ECM Is the replacement complete? | | Go to Step (5) | - |
| 5 | <ul style="list-style-type: none"> • Remove all test equipment except the DST. • Connect any disconnected components, fuses, etc. • Using the DST clear DTC information from the ECM. • Turn the ignition OFF and wait 30 seconds. • Start the engine and operate the vehicle to full operating temperature • Observe the MIL • Observe engine performance and drivability • After operating the engine within the test parameters of DTC-1613 check for any stored codes. Does the engine operate normally with no stored codes? | | System OK | Go to OBD System Check |

DTC 1614-RTI 3 Loss

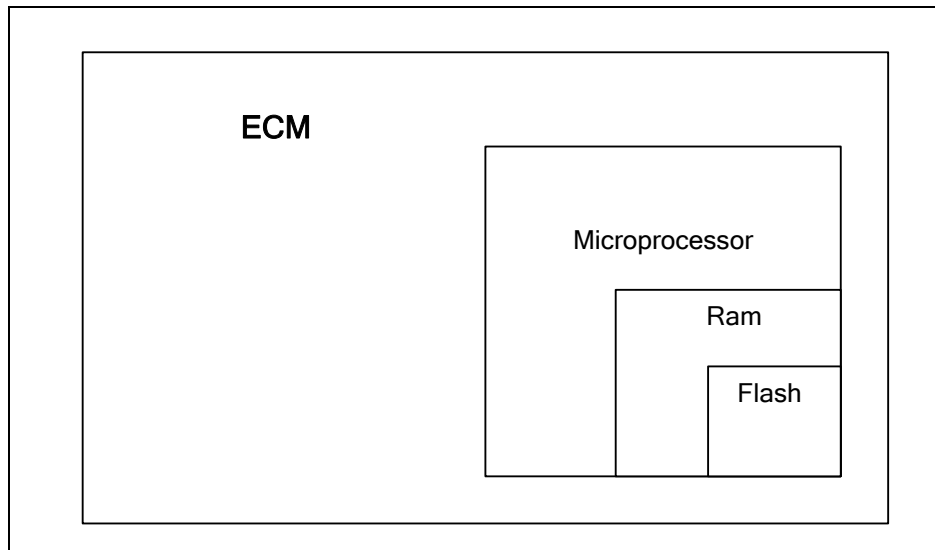

Conditions for Setting the DTC

- Engine Control Module
- Check Condition-Key on
- Fault Condition-Internal microprocessor error
- MIL-ON
- Adaptive-Disabled for the remainder of the key-ON cycle
- Engine shutdown will occur

Circuit Description

The ECM has several internal checks that must be satisfied each time an instruction is executed. Several different things can happen within the microprocessor that will cause this fault. The ECM will attempt to reset itself in the event this fault is set. The MIL command is on and will remain on until the code is cleared using the DST. The engine will shutdown if this code occurs.

DTC 1614-RTI 3 Loss

| Step | Action | Value(s) | Yes | No |
|------|---|----------|----------------|---|
| 1 | Did you perform the On-Board (OBD) System Check? | - | Go to Step (2) | Go to OBD System Check Section |
| 2 | <ul style="list-style-type: none"> • Key ON, Engine Running • DST (Diagnostic Scan Tool) connected in System Data Mode • Clear system fault code Does DTC 1614 reset with the engine idling? | | Go to Step (3) | Intermittent problem Go to Intermittent section |
| 3 | <ul style="list-style-type: none"> • Check ECM power and ground circuits Did the power and ground circuits check OK? | | Go to Step (4) | Repair the circuit as necessary. Refer to Wiring Repairs in Engine Electrical. |
| 4 | <ul style="list-style-type: none"> • Replace ECM Is the replacement complete? | | Go to Step (5) | - |
| 5 | <ul style="list-style-type: none"> • Remove all test equipment except the DST. • Connect any disconnected components, fuses, etc. • Using the DST clear DTC information from the ECM. • Turn the ignition OFF and wait 30 seconds. • Start the engine and operate the vehicle to full operating temperature • Observe the MIL • Observe engine performance and drivability • After operating the engine within the test parameters of DTC-1614 check for any stored codes. Does the engine operate normally with no stored codes? | | System OK | Go to OBD System Check |

DTC 1615-A/D Loss

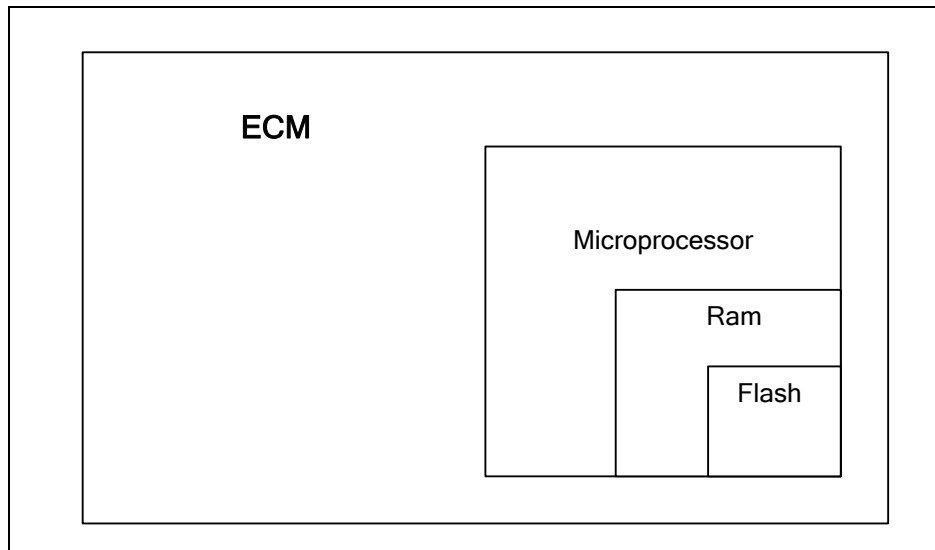

Conditions for Setting the DTC

- Engine Control Module
- Check Condition-Key on
- Fault Condition-Internal microprocessor error
- MIL-ON
- Adaptive-Disabled for the remainder of the key-ON cycle
- Engine shutdown will occur

Circuit Description

The ECM has several internal checks that must be satisfied each time an instruction is executed. Several different things can happen within the microprocessor that will cause this fault. The ECM will attempt to reset itself in the event this fault is set. The MIL command is on and will remain on until the code is cleared using the DST. The engine will shutdown if this code occurs.

DTC 1615-A/D Loss

| Step | Action | Value(s) | Yes | No |
|------|---|----------|----------------|---|
| 1 | Did you perform the On-Board (OBD) System Check? | - | Go to Step (2) | Go to OBD System Check Section |
| 2 | <ul style="list-style-type: none"> • Key ON, Engine Running • DST (Diagnostic Scan Tool) connected in System Data Mode • Clear system fault code Does DTC 1615 reset with the engine idling? | | Go to Step (3) | Intermittent problem Go to Intermittent section |
| 3 | <ul style="list-style-type: none"> • Check ECM power and ground circuits Did the power and ground circuits check OK? | | Go to Step (4) | Repair the circuit as necessary. Refer to Wiring Repairs in Engine Electrical. |
| 4 | <ul style="list-style-type: none"> • Replace ECM Is the replacement complete? | | Go to Step (5) | - |
| 5 | <ul style="list-style-type: none"> • Remove all test equipment except the DST. • Connect any disconnected components, fuses, etc. • Using the DST clear DTC information from the ECM. • Turn the ignition OFF and wait 30 seconds. • Start the engine and operate the vehicle to full operating temperature • Observe the MIL • Observe engine performance and drivability • After operating the engine within the test parameters of DTC-1615 check for any stored codes. Does the engine operate normally with no stored codes? | | System OK | Go to OBD System Check |

DTC 1616-Invalid Interrupt

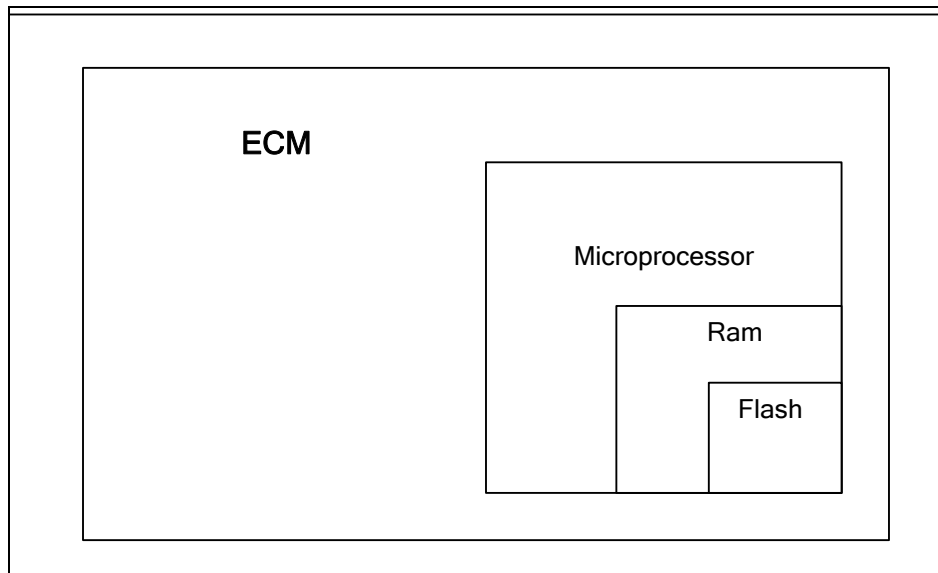

Conditions for Setting the DTC

- Engine Control Module
- Check Condition-Key on
- Fault Condition-Internal microprocessor error
- MIL-ON
- Adaptive-Disabled for the remainder of the key-ON cycle
- Engine Shutdown will occur

Circuit Description

The ECM has several internal checks that must be satisfied each time an instruction is executed. Several different things can happen within the microprocessor that will cause this fault. The ECM will attempt to reset itself in the event this fault is set. The MIL command is on and will remain on until the code is cleared using the DST. The engine will shutdown if this code occurs.

DTC 1616-Invalid Interrupt

| Step | Action | Value(s) | Yes | No |
|------|---|----------|----------------|--|
| 1 | Did you perform the On-Board (OBD) System Check? | - | Go to Step (2) | Go to OBD System Check Section |
| 2 | <ul style="list-style-type: none"> • Key ON, Engine Running • DST (Diagnostic Scan Tool) connected in System Data Mode • Clear system fault code Does DTC 1616 reset with the engine idling? | | Go to Step (3) | Intermittent problem Go to Intermittent section |
| 3 | <ul style="list-style-type: none"> • Check ECM power and ground circuits Did the power and ground circuits check OK? | | Go to Step (4) | Repair the circuit as necessary. Refer to Wiring Repairs in Engine Electrical. |
| 4 | <ul style="list-style-type: none"> • Replace ECM Is the replacement complete? | | Go to Step (5) | - |
| 5 | <ul style="list-style-type: none"> • Remove all test equipment except the DST. • Connect any disconnected components, fuses, etc. • Using the DST clear DTC information from the ECM. • Turn the ignition OFF and wait 30 seconds. • Start the engine and operate the vehicle to full operating temperature • Observe the MIL • Observe engine performance and drivability • After operating the engine within the test parameters of DTC-1616 check for any stored codes. Does the engine operate normally with no stored codes? | | System OK | Go to OBD System Check |

DTC 1626-CAN Tx Failure

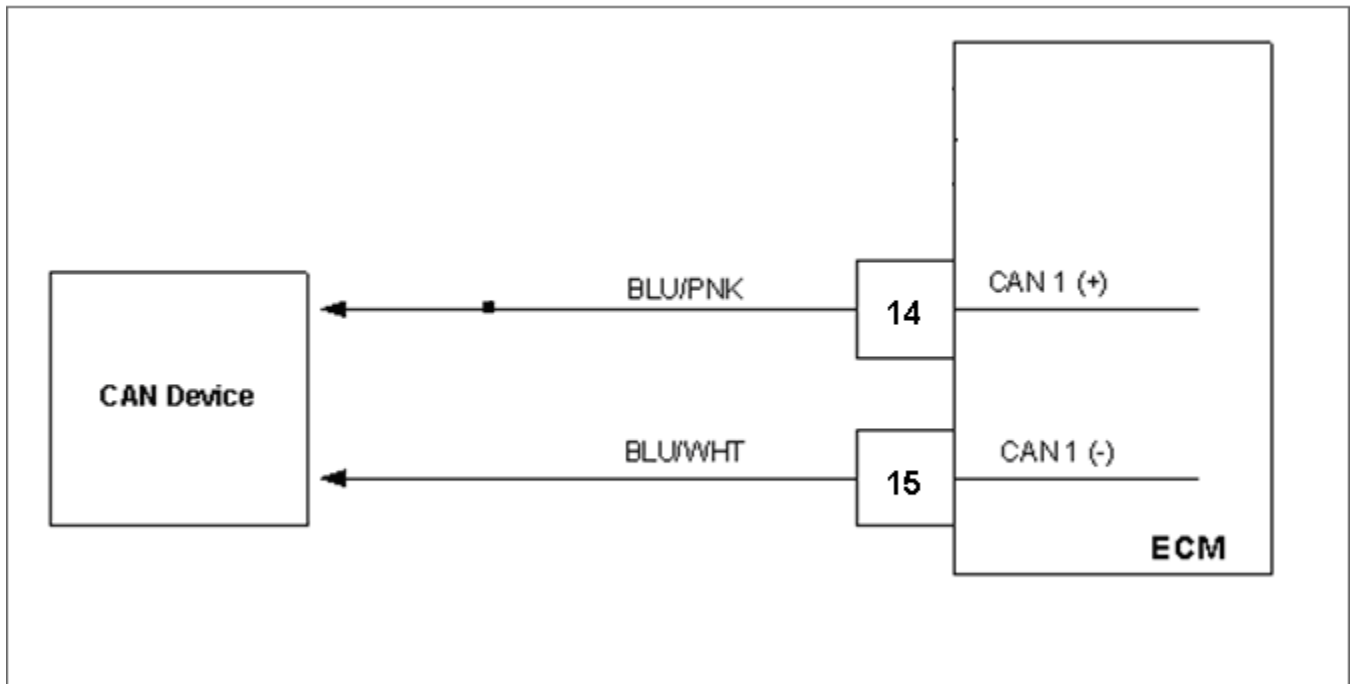

Conditions for Setting the DTC

- CAN Tx
- Check Condition-Engine running
- Fault Condition-CAN Tx error 120 packets lost within 1 second
- MIL-ON

Circuit description

The CAN bus (controller area network) is used by the ECM to communicate with other digital devices used throughout the fuel system. Information is sent over the CAN bus in digital information "packets" that contain information for various control functions. This fault will set if the ECM detects 120 packets lost within a one second time period. The MIL command is ON.

DTC 1626-CAN Tx Failure

| Step | Action | Value(s) | Yes | No |
|------|---|----------|--|--|
| 1 | Did you perform the On-Board (OBD) System Check? | - | Go to Step (2) | Go to OBD System Check Section |
| 2 | <ul style="list-style-type: none"> • Key ON, Engine Running • DST (Diagnostic Scan Tool) connected in System Data Mode • Clear system fault code Does DTC1626 reset with the engine idling? | | Go to Step (3) | Intermittent problem Go to Intermittent section |
| 3 | <ul style="list-style-type: none"> • Check that the ECM power connection C019 is clean, tight and in the proper location. • Check that the ECM ground connection C010 is clean, tight and in the proper location. Are the power and ground circuits OK? | | Go to Step (4) | Repair the circuit as necessary. Refer to Wiring Repairs in Engine Electrical. |
| 4 | <ul style="list-style-type: none"> • Using a DVOM check for continuity between ECM pins 14 and 15 Do you have continuity between them? | | Repair the shorted circuit as necessary. Refer to Wiring Repairs in Engine Electrical. | Go to Step (5) |
| 5 | <ul style="list-style-type: none"> • Using a DVOM check for continuity to engine ground on pins 14 and 15 Do have continuity to engine ground? | | Repair the shorted to ground circuit as necessary. Refer to Wiring Repairs in Engine Electrical. | Go to Step (6) |
| 6 | <ul style="list-style-type: none"> • Using a DVOM check for continuity to battery positive on pins 14 and 15 Do have continuity them? | | Repair the shorted to ground circuit as necessary. Refer to Wiring Repairs in Engine Electrical. | Go to Step (7) |
| 7 | <ul style="list-style-type: none"> • Replace the ECM Is the replacement complete? | | Go to Step (8) | - |

| Step | Action | Value(s) | Yes | No |
|------|--|----------|-----------|------------------------|
| 8 | <ul style="list-style-type: none"> • Remove all test equipment except the DST. • Connect any disconnected components, fuses, etc. • Using the DST clear DTC information from the ECM. • Turn the ignition OFF and wait 30 seconds. • Start the engine and operate the vehicle to full operating temperature • Observe the MIL • Observe engine performance and drivability • After operating the engine within the test parameters of DTC-1626 check for any stored codes. <p>Does the engine operate normally with no stored codes?</p> | | System OK | Go to OBD System Check |

DTC 1627-CAN Rx Failure

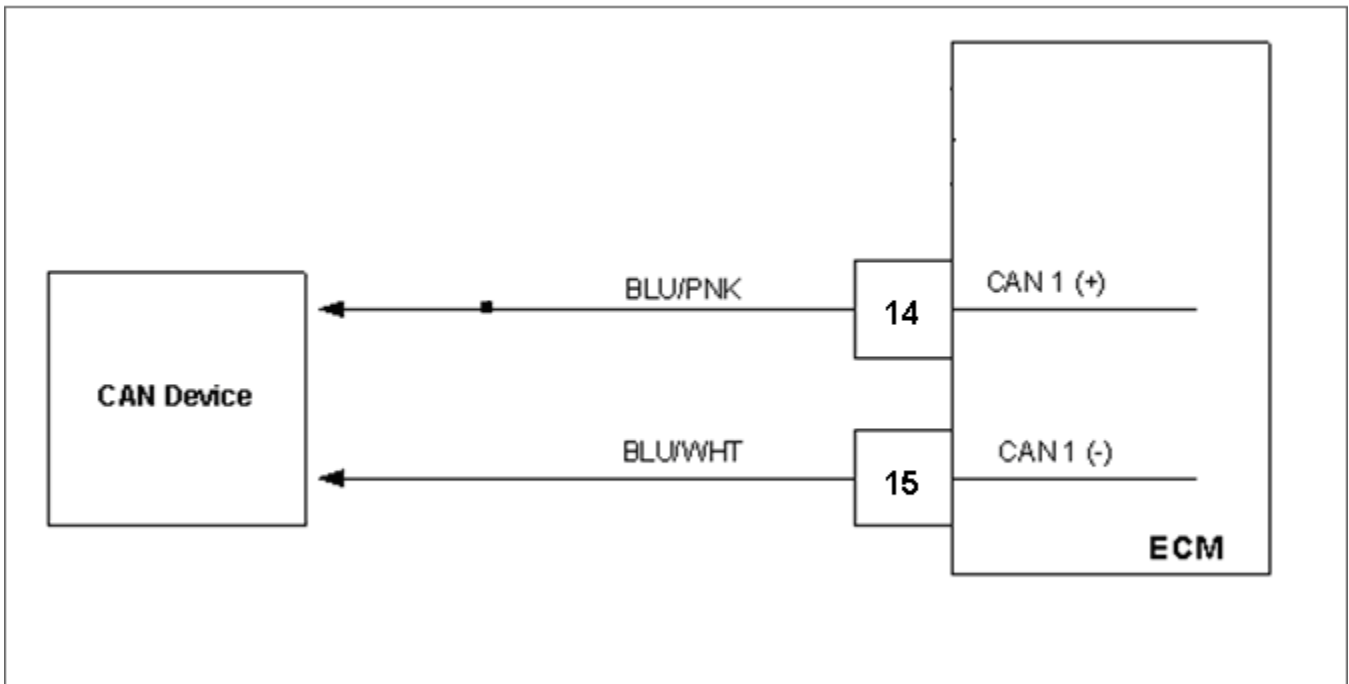

Conditions for Setting the DTC

- CAN Rx
- Check Condition-Engine running
- Fault Condition-CAN Rx error 120 packets lost within 1 second
- MIL-ON

Circuit description

The CAN bus (controller area network) is used by the ECM to communicate with other digital devices used throughout the fuel system. Information is sent over the CAN bus in digital information "packets" that contain information for various control functions. This fault will set if the ECM detects 120 packets lost within a one second time period. The MIL command is ON.

DTC 1627-CAN Rx Failure

| Step | Action | Value(s) | Yes | No |
|------|---|----------|--|--|
| 1 | Did you perform the On-Board (OBD) System Check? | - | Go to Step (2) | Go to OBD System Check Section |
| 2 | <ul style="list-style-type: none"> • Key ON, Engine Running • DST (Diagnostic Scan Tool) connected in System Data Mode • Clear system fault code Does DTC1627 reset with the engine idling? | | Go to Step (3) | Intermittent problem Go to Intermittent section |
| 3 | <ul style="list-style-type: none"> • Check that the ECM power connection C019 is clean, tight and in the proper location. • Check that the ECM ground connection C010 is clean, tight and in the proper location. Are the power and ground circuits OK? | | Go to Step (4) | Repair the circuit as necessary. Refer to Wiring Repairs in Engine Electrical. |
| | | | | |
| 4 | <ul style="list-style-type: none"> • Using a DVOM check for continuity between ECM pins 14 and 15 Do you have continuity between them? | | Repair the shorted circuit as necessary. Refer to Wiring Repairs in Engine Electrical. | Go to Step (5) |
| 5 | <ul style="list-style-type: none"> • Using a DVOM check for continuity to engine ground on pin 15. Do have continuity to engine ground? | | Repair the shorted to ground circuit as necessary. Refer to Wiring Repairs in Engine Electrical. | Go to Step (6) |
| 6 | <ul style="list-style-type: none"> • Using a DVOM check for continuity to battery positive on pin 15. Do have continuity between them? | | Repair the shorted to ground circuit as necessary. Refer to Wiring Repairs in Engine Electrical. | Go to Step (7) |
| 7 | <ul style="list-style-type: none"> • Replace the ECM Is the replacement complete? | | Go to Step (8) | - |

| Step | Action | Value(s) | Yes | No |
|------|--|----------|-----------|------------------------|
| 8 | <ul style="list-style-type: none"> • Remove all test equipment except the DST. • Connect any disconnected components, fuses, etc. • Using the DST clear DTC information from the ECM. • Turn the ignition OFF and wait 30 seconds. • Start the engine and operate the vehicle to full operating temperature • Observe the MIL • Observe engine performance and drivability • After operating the engine within the test parameters of DTC-1627 check for any stored codes. <p>Does the engine operate normally with no stored codes?</p> | | System OK | Go to OBD System Check |

DTC 1628-CAN Address Conflict

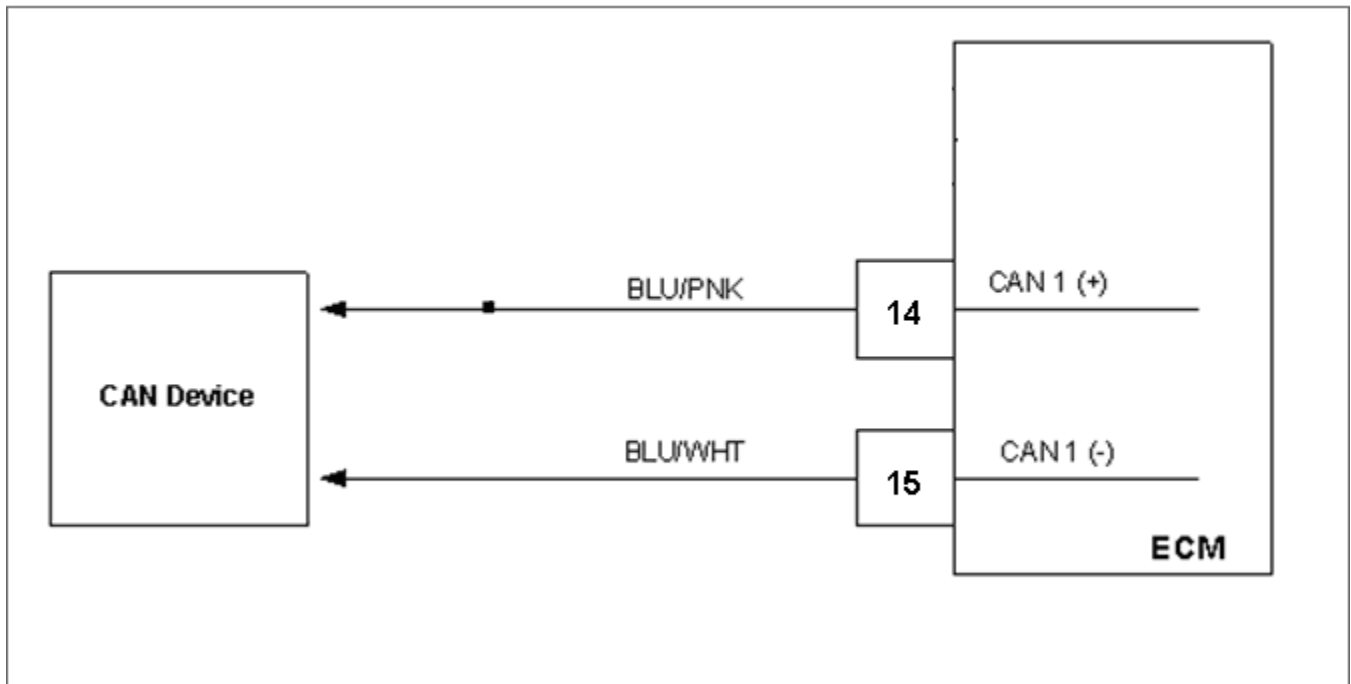

Conditions for Setting the DTC

- CAN Rx
- Check Condition-Engine running
- Fault Condition-5 or more address conflict errors
- MIL-ON

Circuit description

The CAN bus (controller area network) is used by the ECM to communicate with other digital devices used throughout the fuel system. Information is sent over the CAN bus in digital information "packets" that contain information for various control functions. Individual devices are assigned network addresses. This fault will set if the ECM detects an address conflict, such as two devices with the same address. This is usually not due to an in field failure and may be the results of "add on" CAN devices

DTC 1628-CAN Address Conflict

| Step | Action | Value(s) | Yes | No |
|------|---|----------|--|--|
| 1 | Did you perform the On-Board (OBD) System Check? | - | Go to Step (2) | Go to OBD System Check Section |
| 2 | <ul style="list-style-type: none"> • Key ON, Engine Running • DST (Diagnostic Scan Tool) connected in System Data Mode • Clear system fault code Does DTC1628 reset with the engine idling? | | Go to Step (3) | Intermittent problem Go to Intermittent section |
| 3 | <ul style="list-style-type: none"> • Key OFF • Disconnect one CAN device • Clear DTC 1628 • Key ON (start engine if possible if not continue cranking for at least 3 seconds) • Wait 5 seconds Does DTC 1628 re-set? | | Repeat step 3 until all CAN devices have been disconnected one at a time | Contact the CAN device manufacturer for additional CAN address information Go to Step (4) |
| 4 | Has the CAN device been replaced or address conflict resolved? | | Go to Step (5) | - |
| 5 | <ul style="list-style-type: none"> • Remove all test equipment except the DST. • Connect any disconnected components, fuses, etc. • Using the DST clear DTC information from the ECM. • Turn the ignition OFF and wait 30 seconds. • Start the engine and operate the vehicle to full operating temperature • Observe the MIL • Observe engine performance and drivability • After operating the engine within the test parameters of DTC-1628 check for any stored codes. Does the engine operate normally with no stored codes? | | System OK | Go to OBD System Check |

DTC 1644-MIL Control Ground Short

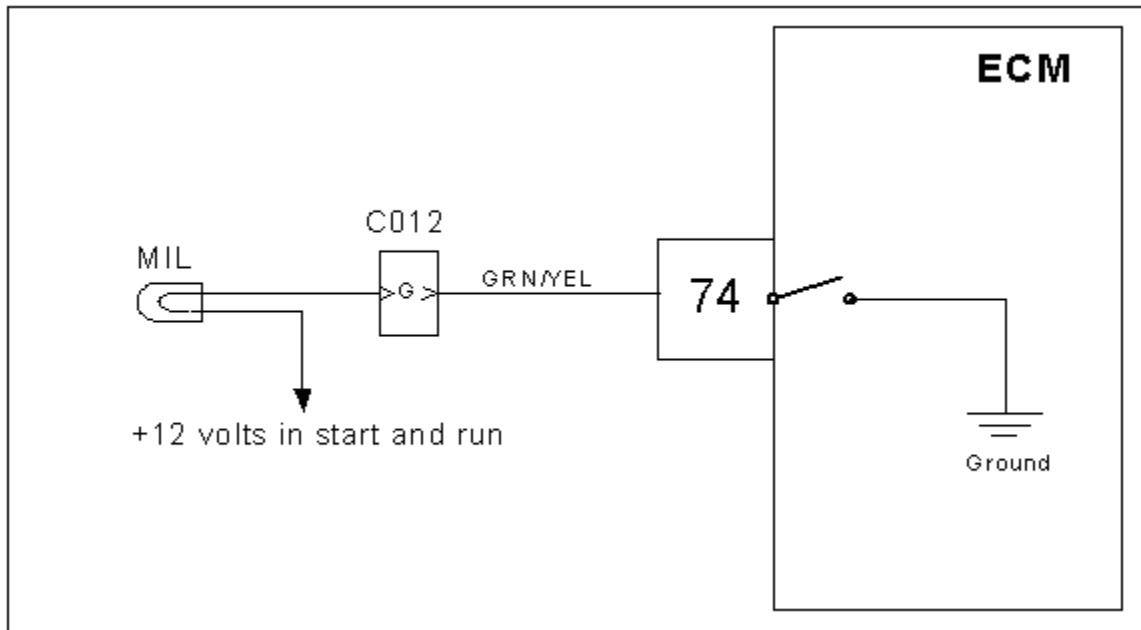

Conditions for setting the DTC

- MIL
- Check Condition-Key ON engine OFF
- Fault Condition-ECM MIL output shorted to ground
- MIL Command-ON

Circuit Description

The Spectrum Fuel system is equipped with OBD (On-Board Diagnostics). The system has a dash mounted MIL (Malfunction Indicator Lamp). The MIL serves as notification of an emissions related problem. The MIL also has the ability to flash DTC codes in what is referred to as the blink code mode. It will display DTCs that have been stored due to a possible system malfunction. The following DTC charts in this manual will instruct the technician to perform the OBD system check. This simply means to verify the operation of the MIL. The lamp should illuminate when the key is in the ON position, and the engine is not running. This feature verifies that the lamp is in proper working order. If the lamp does not illuminate with the vehicle key ON and engine OFF, repair it as soon as possible. Once the engine is in start or run mode, the lamp should go off. If the lamp stays on while the engine is in the start or run mode, a current diagnostic trouble code may be set or a problem may exist with the MIL electrical wiring. The electrical schematic above shows the MIL power source supplied to the lamp. The ECM completes the circuit to ground to turn the lamp ON. This fault will set if the ECM MIL control is shorted to ground.

DTC 1644-MIL Control Ground Short

| Step | Action | Value(s) | Yes | No |
|------|---|----------|---|--|
| 1 | Did you perform the On-Board (OBD) System Check? | - | Go to Step (2) | Go to OBD System Check Section |
| 2 | <ul style="list-style-type: none"> • Key ON, Engine Running • DST (Diagnostic Scan Tool) connected in System Data Mode • Clear system fault code • Key OFF • Key ON Does DTC 1644 reset? | | Go to Step (3) | Intermittent problem Go to Intermittent section |
| 3 | <ul style="list-style-type: none"> • Key OFF • Disconnect the ECM wire harness connector C001 • Using a DVOM check for continuity between ECM connector pin 74 and engine ground Do you have continuity? | | Go to Step (4) | Intermittent problem Go to Intermittent section |
| 4 | <ul style="list-style-type: none"> • Disconnect vehicle interface connector C012 • Using a DVOM check for continuity between ECM connector pin 74 and engine ground Do you have continuity? | | Repair the shorted to ground circuit between the ECM connector and engine ground. Then go to step (6) | Repair the MIL control wire short to ground between the vehicle interface connector and vehicle chassis. Then go to step (6) |
| 5 | <ul style="list-style-type: none"> • Replace the ECM Is the replacement complete? | | Go to Step (7) | - |
| 6 | <ul style="list-style-type: none"> • Remove all test equipment except the DST. • Connect any disconnected components, fuses, etc. • Using the DST clear DTC information from the ECM. • Turn the ignition OFF and wait 30 seconds. • Start the engine and operate the vehicle to full operating temperature • Observe the MIL • Observe engine performance and drivability • After operating the engine within the test parameters of DTC-1644 check for any stored codes. Does the engine operate normally with no stored codes? | | System OK | Go to Step (5) |

| Step | Action | Value(s) | Yes | No |
|------|--|----------|-----------|------------------------|
| 7 | <ul style="list-style-type: none"> • Remove all test equipment except the DST. • Connect any disconnected components, fuses, etc. • Using the DST clear DTC information from the ECM. • Turn the ignition OFF and wait 30 seconds. • Start the engine and operate the vehicle to full operating temperature • Observe the MIL • Observe engine performance and drivability • After operating the engine within the test parameters of DTC-1644 check for any stored codes. <p>Does the engine operate normally with no stored codes?</p> | | System OK | Go to OBD System check |

DTC 1645-MIL Control Ground Short To Power

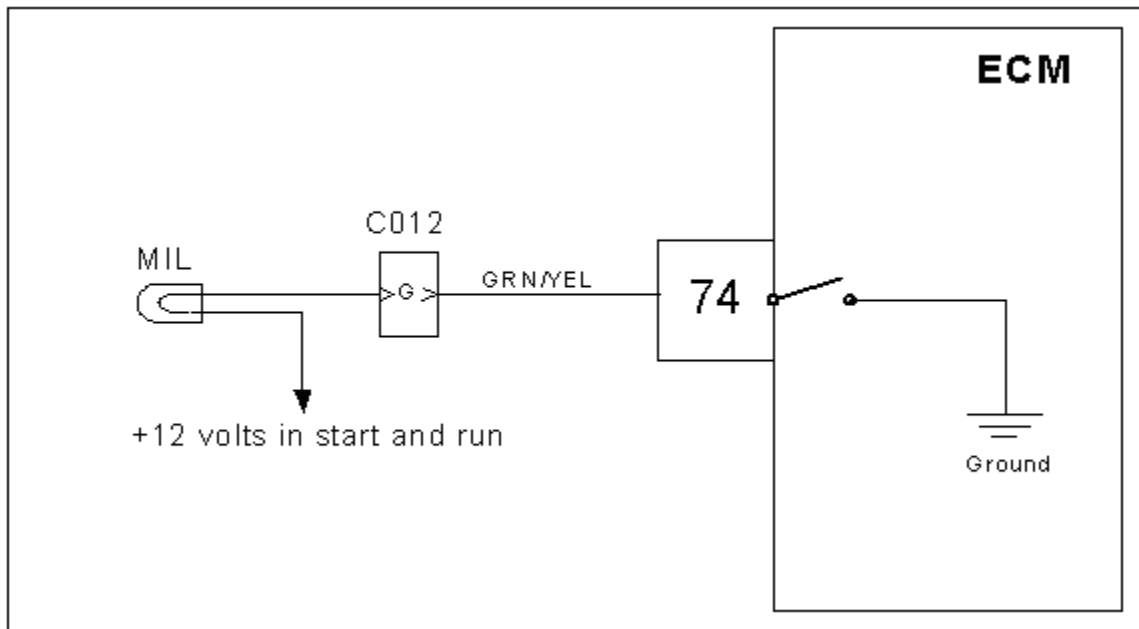

Conditions for setting the DTC

- MIL check
- Check Condition-Key ON engine OFF
- Fault Condition-ECM MIL output shorted to voltage
- MIL Command-ON

Circuit Description

The Spectrum Fuel system is equipped with OBD (On-Board Diagnostics). The system has a dash mounted MIL (Malfunction Indicator Lamp). The MIL serves as notification of an emissions related problem. The MIL also has the ability to flash DTC codes in what is referred to as the blink code mode. It will display DTCs that have been stored due to a possible system malfunction. The following DTC charts in this manual will instruct the technician to perform the OBD system check. This simply means to verify the operation of the MIL. The lamp should illuminate when the key is in the ON position, and the engine is not running. This feature verifies that the lamp is in proper working order. If the lamp does not illuminate with the vehicle key ON and engine OFF, repair it as soon as possible. Once the engine is in start or run mode, the lamp should go off. If the lamp stays on while the engine is in the start or run mode, a current diagnostic trouble code may be set or a problem may exist with the MIL electrical wiring. The electrical schematic above shows the MIL power source supplied to the lamp. The ECM completes the circuit to ground to turn the lamp ON. This fault will set if the ECM MIL control is shorted to voltage.

DTC 1645-MIL Control Short to Power

| Step | Action | Value(s) | Yes | No |
|------|---|----------|--|---|
| 1 | Did you perform the On-Board (OBD) System Check? | - | Go to Step (2) | Go to OBD System Check Section |
| 2 | <ul style="list-style-type: none"> • Key ON, Engine Running • DST (Diagnostic Scan Tool) connected in System Data Mode • Clear system fault code • Key OFF • Key ON Does DTC 1644 reset? | | Go to Step (3) | Intermittent problem Go to Intermittent section |
| 3 | <ul style="list-style-type: none"> • Key OFF • Disconnect the ECM wire harness connector C001 • Using a DVOM check for voltage between ECM connector pin 74 and engine ground • Key ON Do you have voltage? | | Go to Step (4) | Intermittent problem Go to Intermittent section |
| 4 | <ul style="list-style-type: none"> • Disconnect vehicle interface connector C012 • Using a DVOM check for voltage between ECM connector pin 74 and engine ground Do you have voltage? | | Repair the shorted to voltage circuit between the ECM connector and engine ground. Then go to step (6) | Repair the MIL control wire short to voltage between the vehicle interface connector and vehicle chassis. Then go to step (6) |
| 5 | <ul style="list-style-type: none"> • Replace the ECM Is the replacement complete? | | Go to Step (7) | - |
| 6 | <ul style="list-style-type: none"> • Remove all test equipment except the DST. • Connect any disconnected components, fuses, etc. • Using the DST clear DTC information from the ECM. • Turn the ignition OFF and wait 30 seconds. • Start the engine and operate the vehicle to full operating temperature • Observe the MIL • Observe engine performance and drivability • After operating the engine within the test parameters of DTC-1645 check for any stored codes. Does the engine operate normally with no stored codes? | | System OK | Go to Step (5) |

| Step | Action | Value(s) | Yes | No |
|------|--|----------|-----------|------------------------|
| 7 | <ul style="list-style-type: none"> • Remove all test equipment except the DST. • Connect any disconnected components, fuses, etc. • Using the DST clear DTC information from the ECM. • Turn the ignition OFF and wait 30 seconds. • Start the engine and operate the vehicle to full operating temperature • Observe the MIL • Observe engine performance and drivability • After operating the engine within the test parameters of DTC-1645 check for any stored codes. <p>Does the engine operate normally with no stored codes?</p> | | System OK | Go to OBD System check |

DTC 2111-Unable To Reach Lower TPS

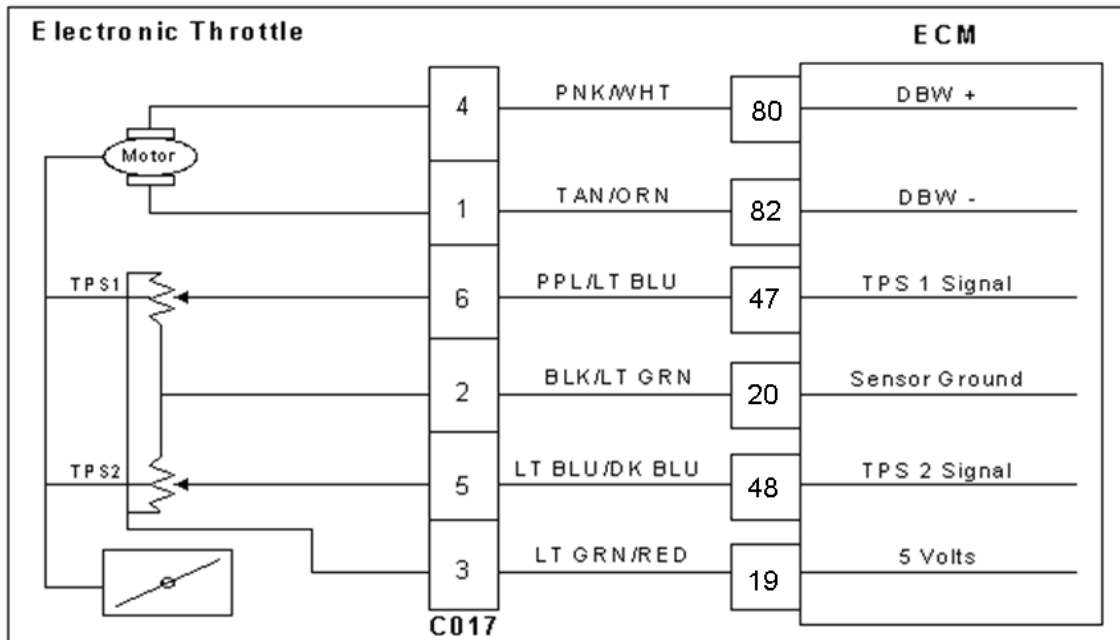

Conditions for Setting the DTC

- Throttle Position Sensor
- Check Condition-Cranking or Running
- Fault Condition-Actual throttle position is 20% greater than the throttle command
- MIL-ON during active fault
- Engine shutdown

Circuit Description

Dual throttle Position Sensors are used within the throttle that use variable resistors to determine signal voltage based on throttle plate position. TPS 1 will read low voltage when closed and TPS 2 will read high voltage when closed. The TPS 1 and TPS 2 percentages are calculated from these voltages. Although the voltages are different, the calculated values for the throttle position percentages should be very close to the same. The TPS values are used by the ECM to determine if the throttle is opening as commanded. This fault will set if the actual throttle position is 20% greater than the throttle command. During this active fault the MIL command is ON and the engine will shutdown.

DTC 2111 Unable To Reach Lower TPS

| Step | Action | Value(s) | Yes | No |
|------|---|----------|--|--|
| 1 | Did you perform the On-Board (OBD) System Check? | - | Go to Step (2) | Go to OBD System Check Section |
| 2 | <ul style="list-style-type: none"> • Key ON, Engine OFF • DST (Diagnostic Scan Tool) connected in DBW (Drive By Wire) test mode • Depress foot pedal until the throttle command is between 63%-68% Is the TPS 1 voltage greater than 2.0 volts? | | Go to Step (3) | Intermittent problem Go to Intermittent section |
| 3 | <ul style="list-style-type: none"> • Key OFF • Disconnect electronic throttle connector C017 • Probe TPS 1 signal pin 6 with a test light connected to battery voltage • Key ON Does DST display TPS 1 voltage less than 0.2 volts? | | Go to Step (6) | Go to Step (4) |
| 4 | <ul style="list-style-type: none"> • Key OFF • Disconnect ECM wire harness connector C001 • Key ON • Using a DVOM check for voltage between throttle connector TPS 1 signal pin 6 and engine ground Do you have voltage? | | Repair the circuit as necessary. Refer to Wiring Repairs in Engine Electrical. | Go to Step (5) |
| 5 | <ul style="list-style-type: none"> • Replace ECM Is the replacement complete? | | Go to Step (13) | - |
| 6 | <ul style="list-style-type: none"> • Probe sensor ground circuit at ECM connector C001 with a test light connected to battery voltage Does the test light come on? | | Go to Step (9) | Go to Step (7) |
| 7 | <ul style="list-style-type: none"> • Key OFF • Disconnect ECM wire harness connector C001 • Using a DVOM check for continuity between throttle connector signal ground pin 2 and ECM signal ground circuit pin 20 Do you have continuity between them? | | Go to Step (8) | Repair the circuit as necessary. Refer to Wiring Repairs in Engine Electrical. |
| 8 | <ul style="list-style-type: none"> • Replace ECM Is the replacement complete? | | Go to Step (13) | - |
| 9 | <ul style="list-style-type: none"> • Check throttle for foreign object in bore Did you find a foreign object in the bore? | | Go to Step (10) | Go to Step (11) |
| 10 | <ul style="list-style-type: none"> • Remove foreign object Is the removal complete? | | Go to Step (13) | - |

| Step | Action | Value(s) | Yes | No |
|------|---|----------|--|------------------------|
| 11 | <ul style="list-style-type: none"> Inspect the throttle wire harness connector terminals for damage, corrosion or contamination Did you find the problem? | | Repair the circuit as necessary. Refer to Wiring Repairs in Engine Electrical. | Go to Step (12) |
| 12 | <ul style="list-style-type: none"> Replace throttle Is the replacement complete? | | Go to Step (13) | - |
| 13 | <ul style="list-style-type: none"> Remove all test equipment except the DST. Connect any disconnected components, fuses, etc. Using the DST clear DTC information from the ECM. Turn the ignition OFF and wait 30 seconds. Start the engine and operate the vehicle to full operating temperature Observe the MIL Observe engine performance and drivability After operating the engine within the test parameters of DTC-2111 check for any stored codes. Does the engine operate normally with no stored codes? | | System OK | Go to OBD System Check |

DTC 2112-Unable To Reach Higher TPS

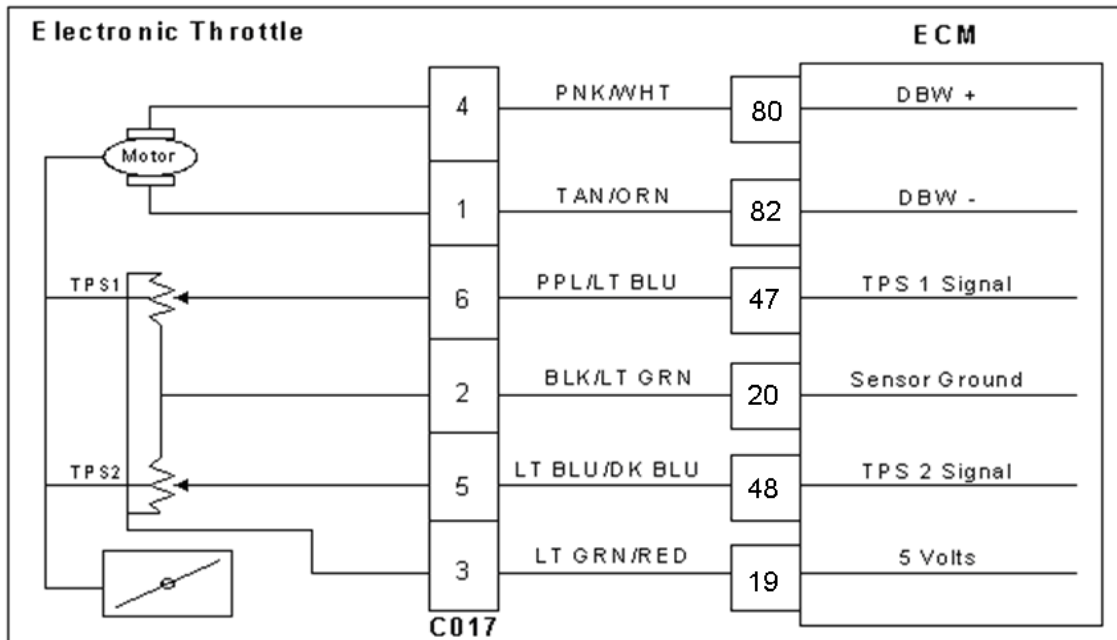

Conditions for Setting the DTC

- Throttle Position Sensor
- Check Condition-Cranking or Running
- Fault Condition-Actual throttle position is 20% less than the throttle command
- MIL-ON during active fault
- Engine shutdown

Circuit Description

Dual throttle Position Sensors are used within the throttle that use variable resistors to determine signal voltage based on throttle plate position. TPS 1 will read low voltage when closed and TPS 2 will read high voltage when closed. The TPS 1 and TPS 2 percentages are calculated from these voltages. Although the voltages are different, the calculated values for the throttle position percentages should be very close to the same. The TPS values are used by the ECM to determine if the throttle is opening as commanded. This fault will set if the actual throttle position is 20% less than the throttle command. The MIL command is ON and the engine will shutdown.

DTC 2112-Unable To Reach Higher TPS

| Step | Action | Value(s) | Yes | No |
|------|---|----------|--|--|
| 1 | Did you perform the On-Board (OBD) System Check? | - | Go to Step (2) | Go to OBD System Check Section |
| 2 | <ul style="list-style-type: none"> • Key ON, Engine OFF • DST (Diagnostic Scan Tool) connected in DBW (Drive By Wire) test mode • Depress foot pedal until the throttle command is 63%-68% Is the TPS voltage less than 2.0 volts? | | Go to Step (3) | Intermittent problem Go to Intermittent section |
| 3 | <ul style="list-style-type: none"> • Key OFF • Disconnect electronic throttle connector C017 • Probe TPS 1 signal circuit pin 6 with test light connected to battery voltage • Key ON Is TPS voltage 4.0 volts or greater? | | Go to Step (4) | Go to Step (8) |
| 4 | <ul style="list-style-type: none"> • Check throttle bore for foreign object Did you find a problem? | | Go to Step (5) | Go to Step (6) |
| 5 | <ul style="list-style-type: none"> • Remove the foreign object Has the object been removed? | | Go to Step (11) | - |
| 6 | <ul style="list-style-type: none"> • Check the electronic throttle connector terminals for damage corrosion or contamination Did you find a problem? | | Repair the circuit as necessary. Refer to Wiring Repairs in Engine Electrical. | Go to Step (7) |
| 7 | <ul style="list-style-type: none"> • Replace throttle Is the replacement complete? | | Go to Step (11) | - |
| 8 | <ul style="list-style-type: none"> • Key OFF • Disconnect ECM wire harness connector C001 • Using a DVOM check for continuity between throttle connector TPS 1 signal pin 6 and ECM TPS 1 signal pin 47 Do you have continuity between them? | | Go to Step (9) | Repair the circuit as necessary. Refer to Wiring Repairs in Engine Electrical. |
| 9 | <ul style="list-style-type: none"> • Using a DVOM check for continuity between throttle connector TPS 1 signal pin 6 and engine ground Do you have continuity between them? | | Repair the shorted to ground circuit as necessary. Refer to Wiring Repairs in Engine Electrical. | Go to Step (10) |
| 10 | <ul style="list-style-type: none"> • Replace ECM Is the replacement complete? | | Go to Step (11) | - |

| Step | Action | Value(s) | Yes | No |
|------|--|----------|-----------|------------------------|
| 11 | <ul style="list-style-type: none"> • Remove all test equipment except the DST. • Connect any disconnected components, fuses, etc. • Using the DST clear DTC information from the ECM. • Turn the ignition OFF and wait 30 seconds. • Start the engine and operate the vehicle to full operating temperature • Observe the MIL • Observe engine performance and drivability • After operating the engine within the test parameters of DTC-2112 check for any stored codes. <p>Does the engine operate normally with no stored codes?</p> | | System OK | Go to OBD System Check |

DTC 2229-BP High Pressure

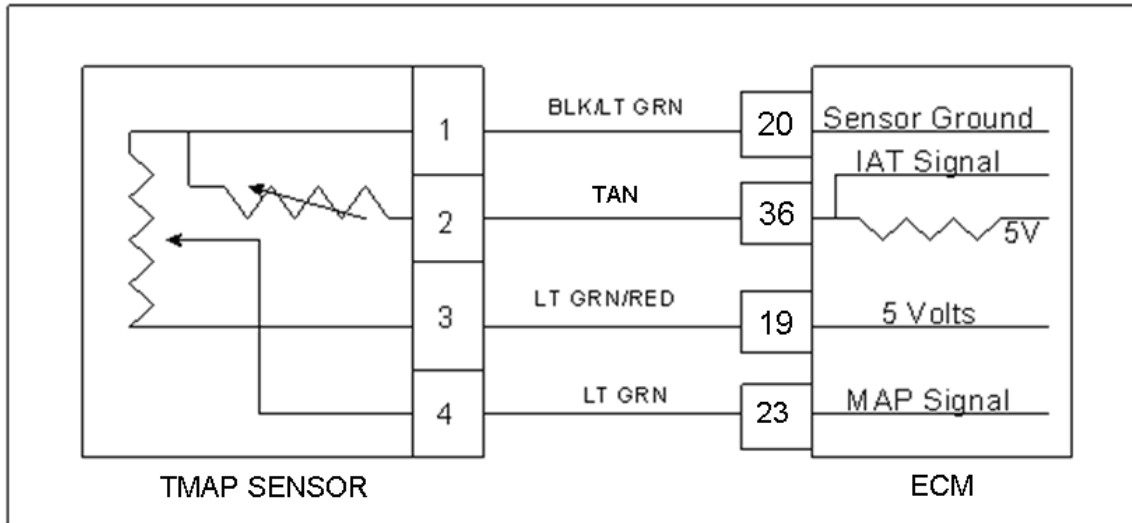

Conditions for Setting the DTC

- Barometric Pressure
- Check Condition-Key ON
- Fault Condition-BP greater than 16 PSIA
- MIL-ON for active fault
- Adaptive-Disabled

Circuit Description

The BP (Barometric Pressure) is estimated from the TMAP sensor. The barometric pressure value is used for fuel and airflow calculations. This fault sets in the event the BP value is out of the normal range.

DTC 2229-BP High Pressure

| Step | Action | Value(s) | Yes | No |
|------|---|----------|----------------|--|
| 1 | Did you perform the On-Board (OBD) System Check? | - | Go to Step (2) | Go to OBD System Check Section |
| 2 | <ul style="list-style-type: none"> • Key ON • DST (Diagnostic Scan Tool) connected in System Data Mode Does DST display MAP pressure of 16 PSIa or greater? | | Go to Step (3) | Intermittent problem Go to Intermittent section |
| 3 | <ul style="list-style-type: none"> • Replace TMAP sensor. Is the repair complete? | | Go to Step 4 | - |
| 4 | <ul style="list-style-type: none"> • Remove all test equipment except the DST. • Connect any disconnected components, fuses, etc. • Using the DST clear DTC information from the ECM. • Turn the ignition OFF and wait 30 seconds. • Start the engine and operate the vehicle to full operating temperature • Observe the MIL • Observe engine performance and drivability • After operating the engine within the test parameters of DTC-2229 check for any stored codes. Does the engine operate normally with no stored codes? | | System OK | Go to OBD System Check |

Definitions

Air Valve Vacuum (AVV): The vacuum signal taken from below the air valve assembly and above the throttle butterfly valve.

ADP: Adaptive Digital Processor.

Air/Fuel Ratio: The amount or balance of air and fuel in the air fuel mixture that enters the engine.

Analog Voltmeter: A meter that uses a mechanical needle to point to a value on a scale of numbers. It is usually of the low impedance type and used to measure voltage and resistance.

Aromatics: Pertaining to or containing the six-carbon ring characteristic of the benzene series. Found in many petroleum distillates.

Backfire: Combustion of the air/fuel mixture in the intake or exhaust manifolds. A backfire can occur if the intake or exhaust valves are open when there is a mis-timed ignition spark.

Benzene: An aromatic (C_6H_6). Sometimes blended with gasoline to improve anti-knock value. Benzene is toxic and suspected of causing cancer.

Bi-Fueled: A vehicle equipped to run on two fuels.

Blow-By: Gases formed by the combustion of fuel and air, which ordinarily should exert pressure only against the piston crown and first compression ring. When rings do not seal, these gases escape or "blow by" the side of the piston into the crankcase.

BTU: British Thermal Unit. A measurement of the amount of heat required to raise the temperature of 1lb. of water 1 degree F.

Butane: An odorless, colorless gas, C_4H_{10} found in natural gas and petroleum. One of the five LP gases.

CAFE: Corporate Average Fuel Economy.

CARB: California Air Resources Board.

Carbon Monoxide (CO): A chemical compound of a highly toxic gas that is both odorless and colorless.

Carburetor: An apparatus for supplying an internal-combustion engine a mixture of vaporized fuel and air.

Cathode Ray Tube: A vacuum tube in which cathode rays usually in the form of a slender beam are projected on a fluorescent screen and produce a luminous spot.

Circuit: A path of conductors through which electricity flows.

Closed Loop Operation: Applies to systems utilizing an oxygen sensor. In this mode of operation, the system uses oxygen sensor information to determine air/fuel ratio. Adjustments are made accordingly and checked by comparing the new oxygen sensor to previous signals. No stored information is used.

CNG: Compressed Natural Gas.

CKP: Crankshaft Position Sensor

CMP: Camshaft Position Sensor

Conductor: A material, normally metallic, that permits easy passage of electricity.

Contaminants: Impurities or foreign material present in fuel.

Control Module: One of several informal names for a solid state microcomputer which monitors engine conditions and controls certain engine functions; i.e. air/fuel ratio, injection and ignition time, etc. The formal name and the one used throughout this manual is ECM, or Engine Control Module.

Converter: A LPG fuel system component containing varying stages of fuel pressure regulation combined with a vaporizer.

Cryogen: A refrigerant used to obtain very low temperatures.

Current: The volume or flow of electrons through a conductor. Measured in amperes or amps.

DBW: Drive By Wire

Dedicated Fuel System: A motor fuel system designed to operate on only one fuel type.

Diaphragm: A thin, flexible membrane that separates two chambers. When the pressure in one chamber is lower than in the other chamber, the diaphragm will move toward the side with the low pressure.

Diaphragm Port: The external port located at the fuel inlet assembly and connected to the vacuum chamber above the air valve diaphragm.

DLC: Data Link Connector.

DTC: Diagnostic Trouble Code

DST: Diagnostic Scan Tool.

DVOM: Digital Volt/ohm Meter. A meter that uses a numerical display in place of a gauge and is usually of the high impedance type.

ECT: Engine Coolant Temperature.

ECM: Electronic Control Module

ECOM: A DLC cable supporting CAN and serial communication with a NGE/EControls ECM.

EFI: Electronic Fuel Injection. A fuel injection system, which uses a microcomputer (ECM) to determine and control the amount of fuel, required by, and injected into, a particular engine.

EGO: Exhaust Gas Oxygen, used to describe a sensor. Also known as "HEGO" (Heat Exhaust Gas Oxygen) sensor, " O_2 " or "Oxygen sensor.

EGR: Exhaust Gas Recirculation.

EPA: Environmental Protection Agency: A regulating agency of the Federal government which, among other duties, establishes and enforces automotive emissions standards.

Ethanol: Grain alcohol (C_2H_5OH), generally produced by fermenting starch or sugar.

Evaporative Emissions Controls: An automotive emission control system designed to reduce hydrocarbon emissions by trapping evaporated fuel vapors from the fuel system.

Excess Flow Valve: A check valve that is caused to close by the fuel when the flow exceeds a predetermined rate.

FTV: Fuel Trim Valve.

FFV: Flexible Fuel Vehicle.

Firing Line: The portion of an oscilloscope pattern that represents the total amount of voltage being expended through the secondary circuit.

FMVSS: Federal Motor Vehicle Safety Standards.

FPP: Foot Pedal Position Sensor

Fuel Injector: a spring loaded, electromagnetic valve which delivers fuel into the intake manifold, in response to an electrical input from the control module.

Fuel Lock: A solenoid-controlled valve located in the fuel line to stop the flow when the engine stops or the ignition switch is off.

Gasohol: 10 percent ethanol, 90 percent gasoline. Often referred to as E-10.

Gasoline: A motor vehicle fuel that is a complex blend of hydrocarbons and additives. Typical octane level is 89.

GCP: Spectrum III (90-pin) ECM.

Greenhouse Effect: A scientific theory suggesting that carbon dioxide from the burning of fossil fuels is causing the atmosphere to trap heat and cause global warming.

HC: Hydrocarbon. An organic chemical compound.

HD 10: A fuel of not less than 80% liquid volume propane and not more than 10% liquid volume propylene.

HD 5: A fuel of not less than 90% liquid volume propane and not more than 5% liquid volume propylene.

H DV: Heavy Duty Vehicle.

Heavy Ends: A term used to describe the build up of wax-like impurities that fall out of LPG when vaporized.

HEGO: Heated Exhaust Gas Oxygen, used to describe a sensor. Also known as "EGO" (Exhaust Gas Oxygen sensor), "O₂" or "Oxygen sensor.

Hg: Chemical symbol for the element mercury. Used in reference to a measure of vacuum (inches of Hg).

Histogram: The graphical version of a table which shows what proportion of values fall into specific categories over a specific period of time.

Hydrocarbon: A chemical compound made up of hydrogen and carbon (HC). Gasoline and almost all other fuels are hydrocarbons.

Hydrostatic Relief Valve: A pressure relief device installed in the liquid LPG hose on a LPG fuel system.

IAT: Intake Air Temperature

Ideal Mixture: The air/fuel ratio at which the best compromise of engine performance to exhaust emissions is obtained. Typically 14.7:1.

Ignition Reserve: The difference between available voltage and the required voltage.

ILEV: Inherently Low Emission Vehicle.

Impedance: A form of opposition of AC electrical current flow (resistance) measured in ohms.

Insulation: A nonconductive material used to cover wires in electrical circuits to prevent the leakage of electricity and to protect the wire from corrosion.

Intercept: An electrical term for a type of splice where the original circuit is interrupted and redirected through another circuit.

Knock: Sound produced when an engine's air/fuel mixture is ignited by something other than the spark plug, such as a hot spot in the combustion chamber. Also caused by a fuel with an octane rating that is too low and/or incorrect ignition timing. Also called detonation or ping.

Lambda Sensor: A feedback device, usually located in the exhaust manifold, which detects the amount of oxygen present in exhaust gases in relation to the surrounding atmosphere. (See HEGO).

LDV: Light Duty Vehicle.

Lean Mixture: An air to fuel ratio above the stoichiometric ratio; too much air.

LEV: Low Emission Vehicle.

Limp-in or Limp Home: A mode where the ECM or a component has failed, but the vehicle remains operational although the engine may operate minimally. This term may also describe the drivability characteristics of a failed computer system.

Liquid Petroleum Gas (LPG): A fuel commonly known as propane consisting mostly of propane (C_3H_8), derived from the liquid components of natural gas stripped out before the gas enters the pipeline, and the lightest hydrocarbons produced during petroleum refining. Octane level of LPG is 107.

LPG: Liquefied Petroleum Gas.

M85: A blend of gasoline and methanol consisting of 85% methanol and 15% gasoline.

Measurements of Pressure: 1 PSI=2.06" Hg

(mercury) = 27.72" H₂O (water column). At sea level atmospheric pressure is 29.92" Hg.

Methanol: Known as wood alcohol (CH₃OH), a light, volatile, flammable alcohol commonly made from natural gas.

MIL: Malfunction Indicator Lamp.

Misfire: Failure of the air/fuel mixture to ignite during the power stroke.

Mixer: Fuel introduction device that does not include a throttle plate.

MFI: Multiport Fuel Injection. A fuel injection system that uses one injector per cylinder mounted on the engine to spray fuel near the intake valve area of combustion chamber.

MSV: Manual Shut-Off Valve. Refers to the manually operated valve on the LPG tank.

MTBE: Methyl Tertiary Butyl Ether. Oxygenate add to gasoline to reduce harmful emissions and to improve the octane rating.

Multi-fuel System: A motor fuel system designed to operate on two different fuels, such as LPG and gasoline.

Natural Gas: A gas formed naturally from buried organic material, composed of a mixture of hydrocarbons, with methane (CH₄) being the dominant component.

NGV: Natural Gas Vehicle.

NOX: See Oxides of Nitrogen.

OBD: On Board Diagnostic

Octane Rating: The measurement of the antiknock value of a motor fuel.

OEM: Original Equipment Manufacturer, the vehicle manufacturer.

Open-Loop: An operational mode during which control module memory information is used to determine air/fuel ratio, injection timing, etc., as opposed to actual oxygen sensor input.

Orifice: A port or passage with a calibrated opening designed to control or limit the amount of flow through it.

Oscilloscope: An instrument that converts voltage and frequency readings into traces on a cathode ray tube (also see Cathode Ray Tube).

Oxides of Nitrogen: Chemical compounds of nitrogen bonded to various amounts of oxygen (NOX). A chief smog forming-agent.

Oxygen Sensor: An automotive fuel system that produces a signal in accordance with the oxygen content of the exhaust gas. (See Lambda Sensor).

Oxygenate: Oxygenates (such as MTBE, ethanol and methanol) added to gasoline to increase the oxygen content and therefore reduce exhaust emissions.

Ozone: A radical oxygen molecule (O₃) that is found in the upper atmosphere and filters out ultraviolet radiation from the sun. Ground level ozone is formed by NOX, during the formation of photochemical smog.

Particulates: Microscopic pieces of solid or liquid substances such as lead and carbon that are discharged into the atmosphere by internal combustion engines.

Positive Crankcase Ventilation (PCV): An automotive emission control system designed to reduce hydrocarbon emissions by routing crankcase fumes into the intake manifold rather than to the atmosphere.

Power Derate: A mode of reduced engine power output for the purposes of protecting engine components during a failure or malfunction.

Pressure Differential: The differential between atmospheric pressure and intake manifold (referred to as vacuum) pressure.

Pressure Regulator: A device to control the pressure of fuel delivered to the fuel injector(s).

Primary Circuit: The low-voltage or input side of the ignition coil.

Propane: An odorless and colorless gas, C₃H₈, found in natural gas and petroleum.

PSIa: pounds per square inch absolute

PTV: Pressure Trim Valve

Reactivity: Refers to the tendency of an HC in the presence of NOX and sunlight to cause a smog-forming reaction. The lighter the HC, the lower reactivity tends to be.

Regulator: An assembly used to reduce and control the pressure of a liquid or vapor.

Resistance: The opposition to the flow of current in an electrical circuit. Measured in ohms.

Rest Pressure: Fuel pressure maintained within the system after engine shutdown.

Rich Mixture: An air to fuel ratio below the stoichiometric ratio; too much fuel.

SAE: Society of Automotive Engineers.

Secondary Circuit: The high-voltage output side of the ignition coil.

SEFI or SFI: Sequential Electronic Fuel Injection or Sequential Fuel Injection.

Sensors: Devices that provide the control module with engine information as needed to properly control engine function.

Spark Line: The portion of an oscilloscope pattern that represents the time during which the air/fuel mixture is being burned in the combustion chamber.

Splice: An electrical term for the joining of two or more conductors at a single point.

Stoichiometric Ratio: An ideal fuel/air ratio for combustion in which all of the fuel and most of the oxygen will be burned.

Sulfur Oxides: Chemical compounds where sulfur is bonded to oxygen produced by the combustion of gasoline or any other fuel that contains sulfur. As sulfur oxides combine with water in the atmosphere to form sulfuric acid.

System Pressure: The fuel pressure maintained in the system during normal engine operation.

Tap: An electrical term for a type of splice where the original circuit is not interrupted.

TBI: Throttle Body Injection. Any of several injection systems that have the fuel injector(s) mounted in a centrally located throttle body.

Throttle Body: Controls engine RPM by adjusting the engine manifold vacuum to the mixer. Consists of a housing shaft, throttle liner and butterfly valve.

TLEV: Transitional Low Emission Vehicle.

TMAP: Combined Air Inlet and Manifold Pressure Sensor.

Toluene: A liquid aromatic hydrocarbon C_7H_8 .

TPS: Throttle Position Sensor.

TSB: Technical Service Bulletin.

ULEV: Ultra Low Emission Vehicle.

USB: Universal Serial Bus. A plug or interface supplied on most personal computers.

Vaporization: A process in which liquid changes states into gas.

Venturi Air Valve Vacuum (VAVV): An amplified air valve vacuum signal coming from the venturi area of the mixer, directly exposed to airflow before the addition of vaporized LPG.

Volt/ohmmeter (VOM): A combination meter used to measure voltage and resistance in an electrical circuit. Available in both analog and digital types. May also referred to as AVOM and DVOM.

Voltage: The electrical pressure that causes current to flow in a circuit. Measured in volts.

Voltage Drop: A lowering of the voltage in a circuit when resistance or electrical load is added.

Voltmeter: A meter that uses a needle to point to a value on a scale of numbers usually of the low impedance type; used to measure voltage and resistance.

VSS: Vehicle Speed Sensor

Xylene: $C_6H_4(CH_3)_2$. Any of three toxic, flammable, and oily isomeric aromatic hydrocarbons that are dimethyl homologues of benzene and usually obtained from petroleum or natural gas distillates.

ZEV: Zero Emission Vehicle.