

Free Floating Lever Drain Traps

For Loads to 49,000 lb/hr (22,226 kg/hr)...Pressures to 300 psig (21 bar)

Armstrong's cast iron, free floating lever drain traps use the same bodies, caps, lever mechanisms, valves and seats of Armstrong inverted bucket steam traps that have been proven in years of service. Elliptical floats and high leverage make it possible to open large orifices to provide adequate capacity for drain trap size and weight.

2-LD, 3-LD and 6-LD cast iron traps are identical in design, materials and workmanship to those for saturated steam service up to 300 psig (21 bar) with the exception of the addition of a guidepost to assure a positive, leaktight valve closing under all conditions.

List of Materials

Table LD-15.					
Model No.	Valve & Seat	Leverage System	Float	Body & Cap	Gasket
1-LD 2-LD 3-LD 6-LD	Stainless Steel			Cast Iron ASTM A48 Class 30	Compressed Asbestos-free

For information on special materials, consult the Armstrong Application Engineering Department.

The hemispherical valve, seat and leverage of the 1-LD,

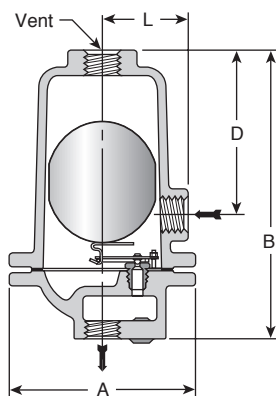

Figure LD-33.

No. 2-LD, 3-LD and 6-LD cast iron guided lever drain traps. No. 1-LD has standard top inlet and optional side connection.



Physical Data

Model No.	Cast Iron							
	1-LD		2-LD		3-LD		6-LD	
Pipe Connections	in	mm	in	mm	in	mm	in	mm
	1/2*	15*	1/2, 3/4	15, 20	1/2, 3/4, 1	15, 20, 25	1-1/2, 2	40, 50
"A"	3-3/4	95	5-1/4	133	6-3/8	162	10-3/16	259
"B"	5-1/2	140	8-3/4	222	11-1/2	292	18	457
"D"	2-7/8	73	5-1/8	130	7	188	9-3/8	238
"K" (☉ Outlet to ☉ Inlet)	13/16	21	—	—	—	—	—	—
"L"	1-7/8	48	2-7/16	62	2-7/8	73	4-5/8	117
Approx. Wt. lb (kg)	4 (2)		12 (5.5)		21 (9.5)		78 (35.5)	
Max. Allow. Pressure (Vessel Design)	300 psig @ 200°F† (21 bar @ 93°C)		250 psig @ 450°F (17 bar @ 232°C)					

NOTE: Vessel design pressure may exceed float collapse pressure in some cases.

Pipe size of vent connection is same as that of inlet and outlet connections.

†For pressures not exceeding 250 psig (17 bar), a maximum temperature of 450°F (232°C) is allowed.

*1/4" (6 mm) outlet.

Designs, materials, weights and performance ratings are approximate and subject to change without notice. Visit armstronginternational.com for up-to-date information.



Free Floating Lever Drain Traps

For Loads to 9,500 lb/hr (4,309 kg/hr)...Pressures to 570 psig (39 bar)

Armstrong's stainless steel, free floating lever drain traps use the same bodies, caps, lever mechanisms, valves and seats of Armstrong inverted bucket steam traps that have been proven in years of service. Elliptical floats and high leverage make it possible to open large orifices to provide adequate capacity for drain trap size and weight.

22-LD and 13-LD stainless steel traps are identical in design, materials and workmanship to those for saturated steam service up to 570 psig (39 bar) with the exception of the addition of a guidepost to assure a positive, leaktight valve closing under all conditions.

List of Materials

Table LD-17.

Model No.	Valve & Seat	Leverage System	Float	Body & Cap	Gasket
11-LD 22-LD 13-LD	Stainless Steel			Sealed Stainless Steel, 304L	—

For information on special materials, consult the Armstrong Application Engineering Department.

The hemispherical valve, seat and leverage of the 11-LD,

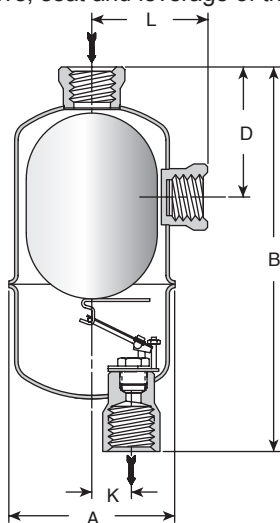

Figure LD-34.

No. 22-LD and 13-LD stainless steel guided lever liquid drain trap with sealed, tamperproof construction.



Physical Data

Table LD-18. Armstrong Guided Lever Liquid Drain Traps

Model No.	Stainless Steel					
	11-LD**		22-LD		13-LD	
Pipe Connections	in	mm	in	mm	in	mm
	3/4*	20*	3/4	20	1	25
"A"	2-3/4	70	3-15/16	100	4-1/2	114
"B"	7-1/4	184	8-13/16	224	11-3/8	289
"D"	—	—	3	76	6-1/8	156
"K"	9/16	14	7/8	22	1-3/16	30
"L"	—	—	2-5/8	67	3-9/32	83
Approx. Wt. lbs (kg)	1-3/4 (0.79)		3-1/4 (1.5)		7-1/2 (3.4)	
Max. Allowable Pressure (Vessel Design)	500 psig @ 100°F (35 bar @ 38°C) 440 psig @ 500°F (30 bar @ 260°C)		600 psig @ 100°F (41 bar @ 38°C) 475 psig @ 500°F (33 bar @ 260°C)		570 psig @ 100°F (39 bar @ 38°C) 490 psig @ 500°F (34 bar @ 260°C)	

Note: Vessel design pressure may exceed float collapse pressure in some cases.

Pipe size of vent connection is same as that of inlet and outlet connections.

*1/2" (15 mm) outlet. **No side connection.

Free Floating Lever Drain Traps

For Loads to 42,000 lb/hr (19,050 kg/hr)...Pressures to 1,000 psig (69 bar)

Armstrong's forged steel, free floating lever drain traps use the same bodies, caps, lever mechanisms, valves and seats of Armstrong inverted bucket steam traps that have been proven in years of service. Elliptical floats and high leverage make it possible to open large orifices to provide adequate capacity for drain trap size and weight.

The hemispherical valve, seat and leverage of the 32-LD, 33-LD and 36-LD forged steel traps are identical in design, materials and workmanship to those for saturated steam traps up to 1,000 psig (69 bar) with the exception of the addition of a guidepost to assure a positive, leaktight valve closing under all conditions.

List of Materials

Model No.	Valve & Seat	Leverage System	Float	Body & Cap	Gasket
32-LD 33-LD 36-LD		Stainless Steel		Forged Steel ASTM A105	Compressed Asbestos-free

For information on special materials, consult the Armstrong Application Engineering Department.

For a fully detailed certified drawing, refer to CD #1035.

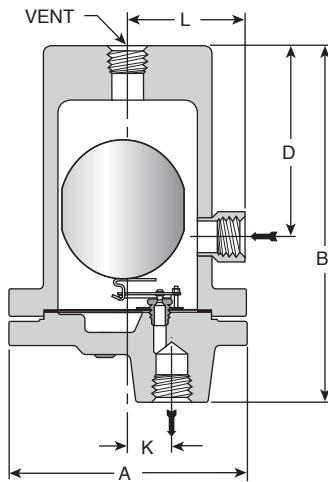

Figure LD-37.

No. 32-LD, 33-LD and 36-LD forged steel guided lever drain trap. Socketweld or flanged connections are also available.



Physical Data

Model No.	Forged Steel					
	32-LD†		33-LD†		36-LD†	
Pipe Connections	in	mm	in	mm	in	mm
		1/2, 3/4, 1	15, 20, 25	1/2, 3/4, 1	15, 20, 25	1-1/2, 2
"A"	6-3/4	171	8	203	11-7/8	302
"B"	10-3/16	259	11-9/16	294	17-1/8	435
"D"	5-9/16	141	6-1/16	154	9	229
"K"	1-1/4	32	1-7/16	37	2-1/8	54
"L"	3-3/8	86	3-9/16	90	6-1/16	154
Approx. Wt. lbs (kg)	31 (14)		49 (22)		163 (74)	
Max. Allowable Pressure (Vessel Design)	600 psig @ 100°F (41 bar @ 38°C) 500 psig @ 750°F (35 bar @ 400°C)		1,000 psig @ 100°F (69 bar @ 38°C) 600 psig @ 750°F (41 bar @ 400°C)			

Note: Vessel design pressure may exceed float collapse pressure in some cases.

Pipe size of vent connection is same as that of inlet and outlet connections.

†Available in Type 316 stainless steel. Consult factory.

Designs, materials, weights and performance ratings are approximate and subject to change without notice. Visit armstronginternational.com for up-to-date information.



180 Series Free Floating Lever Drain Traps

All Stainless Steel for Horizontal Installation

For pressures to 400 psig (28 bar) . . . Capacities to 2,000 lb/hr (907 kg/hr)

Armstrong's stainless steel, free floating lever drain traps use the same bodies, caps, lever mechanisms, valves and seats as Armstrong inverted bucket steam traps that have been proven in years of service. Elliptical floats and high leverage make it possible to open large orifices to provide adequate capacity for drain trap size and weight.

The hemispherical valve, seat and leverage of the 180-LD and 181-LD stainless steel traps are identical in design, materials and workmanship to those for saturated steam service up to 570 psig (39 bar), except that the 180 Series traps have a guidepost to ensure a positive, leak-tight valve closing under all conditions. The 180 Series is designed for situations where mounting a drainer close to the floor is critical. A back vent connection is required.

For a fully detailed certified drawing, refer to list below:
180-LD CD #1276

List of Materials

Model No.	Valve & Seat	Leverage System	Float	Body & Cap
180-LD 181-LD		Stainless Steel		Sealed Stainless Steel 304L

Physical Data

Model No.	180-LD		181-LD	
	in	mm	in	mm
Pipe Connections	1/2	15	3/4	20
"A" (Diameter)	2-11/16	68	2-11/16	68
"B" (Height)	6	152	7-1/4	184
"C" (Face to Face)	4-5/16	110	4-5/16	110
"D" (Bottom to C Inlet)	5-1/8	130	6-9/32	160
"P"	1/2	15	3/4	20
Weight, lb (kg)	1-3/4 (0.8)		2-3/8 (1.1)	
Max. Allowable Pressure (Vessel Design)	500 psig @ 100°F (35 bar @ 38°C) 440 psig @ 500°F (30 bar @ 260°C)			

Note: Vessel design pressure may exceed float collapse pressure in some cases. Pipe size of vent is same as that of inlet and outlet connections.

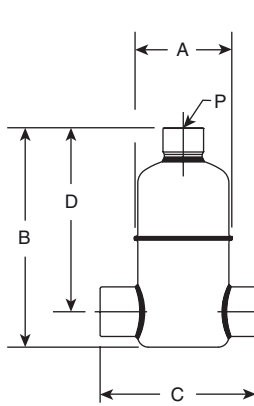

Figure LD-35.
Model 180-LD

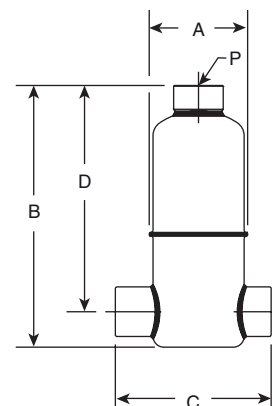
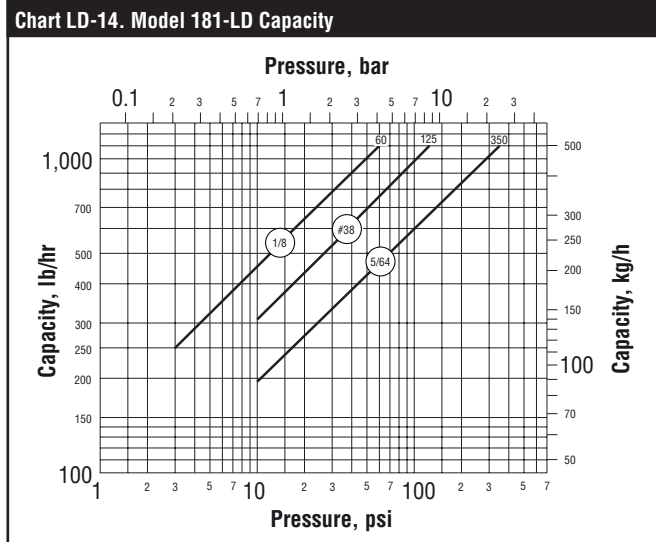
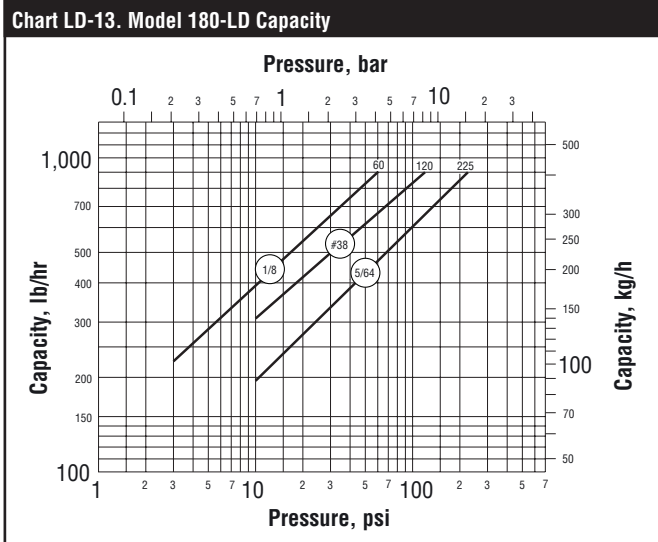

Figure LD-36.
Model 181-LD



Designs, materials, weights and performance ratings are approximate and subject to change without notice. Visit armstronginternational.com for up-to-date information.