

Technical catalog



Tmax. T Generation

Low voltage molded case
circuit breakers up to 1200 A

UL 489 and CSA C22.2 Standard

1SDC210023D0201 – 2008 edition



ABB

Construction characteristics

Distinguishing features of the series

1

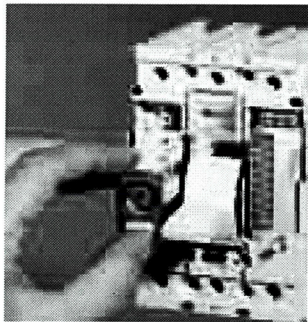

Double insulation

Tmax has double insulation between the live power parts (excluding the terminals) and the front of the apparatus where the operator works during normal operation of the device. The placement of each electrical accessory is completely segregated from the power circuit, preventing any risk of contact with live parts and the operating mechanism is completely insulated from the powered circuits. Furthermore, the circuit breaker has oversized insulation, both between the live internal parts and in the area of the connection terminals. In fact, the distances exceed those required by the IEC Standards and comply with the UL 489 Standard.



Positive operation

The operating lever always indicates the precise position of the moving contacts of the circuit breaker, thereby providing safe and reliable signals, in compliance with IEC 60073 and IEC 60417-2 Standard (I = Closed; O = Open; yellow-green line = Open due to protection trip). The circuit breaker operating mechanism is trip free regardless of the pressure on the lever. Protection tripping automatically opens the moving contacts: to close them again the operating mechanism must be reset by pushing the operating lever from the tripped position into the reset position.

Isolation behaviour

In the open position, the circuit breaker complies with the IEC 60947-2 Standard. The oversized insulation distances guarantee there are no leakage currents and dielectric resistance to any overvoltages between input and output.

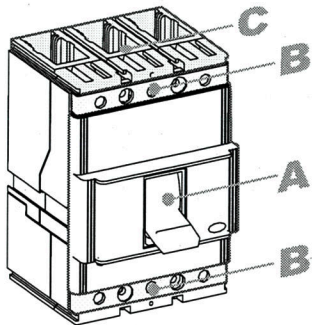
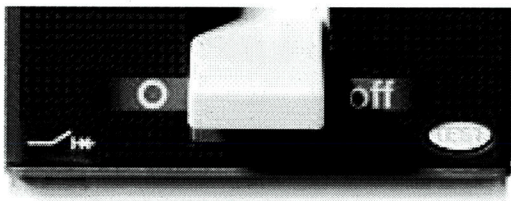

Degrees of protection

The table indicates the degrees of protection guaranteed by the Tmax circuit breakers according to the IEC 60529 Standard:

	With front	Without front ⁽²⁾	Without terminal covers	With high terminal covers	With low terminal covers	With IP40 protection kit on the front
A	IP 40 ⁽³⁾	IP 20	–	–	–	–
B ⁽⁴⁾	IP 20	IP 20	IP 20	IP 40	IP 40	IP 40
C	–	–	–	IP 40 ⁽¹⁾	IP 30 ⁽¹⁾	–

⁽¹⁾ After correct installation

⁽²⁾ During installation of the electrical accessories

⁽³⁾ Also for front for lever operating mechanism and direct rotary handle

⁽⁴⁾ Only for T1...T6

The cradles are always preset with IP20 degree of protection. IP54 degree of protection can be obtained with the circuit breaker installed in a switchboard fitted with a rotary handle operating mechanism transmitted on the compartment door and special kit (RHE – IP54).

Operating temperature

The Tmax circuit breakers can be used in ambient conditions where air temperature varies between -13 °F and +158 °F (-25 °C and +70 °C), and stored in environments with temperatures between -40 °F and +158 °F (-40 °C and +70 °C).

The circuit breakers fitted with thermal magnetic trip units have their thermal element set for a reference temperature of 104 °F (+40 °C). For temperatures other than 104 °F (+40 °C), with the same setting, there is a deviation table as shown beginning on page 4/50.

The electronic trip units do not undergo any variations in performance as the temperature varies except in cases of temperatures exceeding 104 °F (+40 °C). Then maximum setting for protection against overloads L must be reduced, as indicated in the derating graph beginning on page 4/37, to take into account the heating phenomena which occur in the current carrying copper parts of the circuit breaker.

For temperatures above 158 °F (+70 °C) the circuit breaker performances are not guaranteed. To ensure service continuity of the installations, the temperature must be kept within acceptable levels for operation of the various devices and the circuit breakers by using forced ventilation in the switchboards or in their installation room.



1SDC210031F0001

Altitude

Up to an altitude of 6600 ft the Tmax circuit breakers do not undergo any changes in their rated performance. Above this altitude, the atmospheric properties are altered in terms of composition, dielectric resistance, cooling capacity and pressure, requiring the circuit breaker performance to be derated per the table below.

Altitude	[ft]	6600	9900	13200	16500
Rated service voltage, Ue	[V~]	600	522	435	348
Rated uninterrupted current, Iu	%Iu	100	98	93	90

Construction characteristics

Distinguishing features of the series

1



Electromagnetic compatibility

Protection operation is guaranteed by using the electronic trip units and the electronic residual current releases in the presence of interference caused by electronic devices, atmospheric disturbances or electrical discharges. No interference with other electronic devices near the place of installation is generated either. This is in compliance with the IEC 60947-2 Appendix B + Appendix F Standards and European Directive No. 89/336 regarding EMC - electromagnetic compatibility.

1SDC210023D001



Tropicalization

Circuit breakers and accessories in the Tmax series are tested in compliance with the IEC 60068-2-30 Standard, carrying out 2 cycles at 131 °F (55 °C) with the "variant 1" method (clause 6.3.3). The suitability of the Tmax series for use under the most severe environmental conditions is therefore ensured with the hot-humid climate defined in the climatograph 8 of the IEC 60721-2-1 Standards thanks to:

- moulded insulating cases made of synthetic resins reinforced with glass fibres;
- anti-corrosion treatment of the main metallic parts;
- Fe/Zn 12 zinc-plating (ISO 2081) protected by a conversion layer, free from hexavalent-chromium (ROHS-compliant), with the same corrosion resistance guaranteed by ISO 4520 class 2c;
- application of anti-condensation protection for electronic overcurrent releases and relative accessories.

1SDC210023D001

Resistance to shock and vibration

The circuit breakers are unaffected by vibrations generated mechanically or due to electromagnetic effects, in compliance with the IEC 60068-2-6 Standards and the regulations of the major classification organizations⁽¹⁾:

- RINA
- Det Norske Veritas
- Bureau Veritas
- Lloyd's register of shipping
- Germanischer Lloyd
- ABS
- Russian Maritime Register of Shipping.

The T1-T5 Tmax circuit breakers are also tested according to the IEC 60068-2-27 Standard to resist shock up to 12g for 11 ms. Please ask ABB for details about higher performance in terms of resistance to shock.



⁽¹⁾ Ask to ABB for Tmax certificates of approval.



Compliance with Standards and company Quality System

The Tmax circuit breakers and their electrical accessories conform to the UL 489 (Underwriters Laboratories Incorporated) and CSA C22.2 No. 5.1 (Canadian Standard Association) North American Standards, and to the international IEC 60947-2 Standards and comply with the EC directive:

- "Low Voltage Directives" (LVD) no. 2006/95/CE (replaces 72/23/EEC and subsequent amendments)
- "Electromagnetic Compatibility Directive" (EMC) no. 89/336 EEC.

Certification of compliance with the above-mentioned product Standards is carried out, in respect of the European EN 45011 Standard, by the Italian certification body ACAE (Association for Certification of Electrical Apparatus), a member of the European LOVAG organization (Low Voltage Agreement Group).

The ABB test laboratory is accredited by SINAL (certificate no. 062/2002).

The ABB Quality System complies with the international ISO 9001 - 2000 Standard (model for quality assurance in design, development, construction, installation and service) and with the equivalent European EN ISO 9001 and Italian UNI EN ISO 9001 Standards.

The independent certifying Body is RINA S.p.A. ABB obtained its first certification with three-year validity in 1990, and has now reached its fourth reconfirmation.

The new Tmax series has a hologram on the front, obtained using special anti-imitation techniques, which guarantees the quality and that the circuit breaker is an original ABB product.

Attention to protection of the environment and to health and safety in the work place is another priority commitment for ABB and, as confirmation of this, the company environmental management system has been certified by RINA in 1997, in conformity with the international ISO 14001 Standard. This certification has been integrated in 1999 with the Management System for Health and Safety in the workplace, according to OHSAS 18001 (British Standards), obtaining one of the first certification of integrated management System, QES (Quality, Environment, Safety) issued by RINA. ABB – the first industry in the electromechanical section in Italy to obtain this recognition – thanks to a revision of the production process with an eye to ecology, has been able to reduce the consumption of raw materials and processing waste by 20%.

ABB's commitment to safeguarding the environment is also shown by the Life Cycle Assessments of its products carried out directly by ABB Research and Development in collaboration with the ABB Research Center. Selection of materials, processes and packing materials is made optimizing the true environmental impact of the product, also foreseeing the possibility of its being recycled.

Power distribution circuit breakers

Electrical characteristics

MCCB

Type		Tmax T1 1p	Tmax T1	Tmax T2		Tmax T3		Tmax Ts3		
Frame size	[A]	100	100	100		225		150		
Number of poles	[No.]	1	3-4	3 ⁽⁶⁾ -4		3-4		2-3-4		
Rated voltage	AC (50-60 Hz)	347	600Y/347	480		600Y/347		600		
	DC		500			500		600		
Interrupting ratings		B	N	S	H	N	S	N	H	L
240 V AC	[kA rms]	18 ⁽¹⁾	50 ⁽²⁾	65	150	50	65	65	100	150
277 V AC	[kA rms]	14 ⁽¹⁾								
347 V AC	[kA rms]									
480 V AC	[kA rms]		22 ⁽²⁾	35	65	25	35	25	50	85 ⁽⁶⁾
600Y/347 V AC	[kA rms]		10			10	10			
600 V AC	[kA rms]							14	14	25
250 V DC (2 poles in series)	[kA rms]		25			25	35			
500 V DC (3 poles in series)	[kA rms]		25			25	35			
500 V DC (2 poles in series)	[kA rms]							35	50	65
600 V DC (3 poles in series)	[kA rms]							20	35	50
Versions		F	F	F-P		F-P		F-P-W		
Trip units	TMF	■	■	■		■		■		
	TMD/TMA									
	MA			■		■		■		
	Electronic									
	PR221DS			■						
	PR222DS/P									
	PR222DS/PD-A									
	PR231/P									
	PR232/P									
	PR331/P									
PR332/P										
Dimensions	H [in/mm]	5.12/130	5.12/130	5.12/130		5.9/150		6.7/170		
	W 3p [in/mm]	1/25.4	3/76	3.54/90		4.13/105		4.13/105		
	D [in/mm]	2.76/70	2.76/70	2.76/70		2.76/70		4.07/103.5		
Mechanical life	[No. operations]	25000	25000	25000		25000		25000		

⁽¹⁾ In 15 A = 10 kA @ 277 V AC - 10 kA @ 347 V AC

⁽²⁾ In 15 A = 35 kA @ 240 V AC - 14 kA @ 480Y/277 V AC

⁽³⁾ T5 600 with electronic trip units only and in three pole version

⁽⁴⁾ 2p T4250 and T5400 available only in N interrupting rating

⁽⁵⁾ In from 15 A up to 30 A = 65 kA @ 480 V AC
T2H 100 3p, T4H 250 3p, T4V 250 3p, T5H 400 3p,
T5V 400 3p are defined current limiting. See the
current limiting chapter

F = Fixed
P = Plug-in
W = Draw-out

Tmax Ts3			Tmax T4					Tmax T5					Tmax T6				Tmax T7		
225			250					400-600 ⁽³⁾					800				1000-1200		
2-3-4			2 ⁽⁴⁾ -3 ⁽⁶⁾ -4					2 ⁽⁴⁾ -3 ⁽⁶⁾ -4					3-4				3-4		
480			600					600					600				600		
500			600					600					600						
N	H	L	N	S	H	L	V	N	S	H	L	V	N	S	H	L	S	H	L
65	100	150	65	100	150	200	200	65	100	150	200	200	65	100	200	200	65	100	150
25	50	65	25	35	65	100	150	25	35	65	100	150	35	50	65	100	50	65	100
			18	25	35	65	100	18	25	35	65	100	20	25	35	42	25	50	65
20	35	50	25	35	50	65	100	25	35	50	65	100	35	35	50	65			
			16	25	35	50	65	16	25	35	50	65	20	20	35	50			
F-P-W			F-P-W					F-P-W					F-W				F-W		
■			■					■					■				■		
■			■					■					■				■		
			■					■					■				■		
			■					■					■				■		
			■					■					■				■		
6.7/170			8.07/205					8.07/205					10.55/268				10.55/268		
4.13/105			4.13/105					5.51/140					8.26/210				8.26/210		
4.07/103.5			4.07/103.5					4.07/103.5					4.07/103.5				6.06/154(toggle)-7/178(motor)		
25000			20000					20000					20000				10000		

Power distribution circuit breakers

Electronic trip units

For use in alternating current the Tmax T2, T4, T5, T6 and T7 circuit breakers can be equipped with trip units constructed using electronic technology. This allows protection functions to be obtained which provide high reliability, tripping precision and insensitivity to temperature and to the electromagnetic components.

The power supply needed for correct operation is supplied directly by the current sensors of the trip unit, and tripping is always guaranteed, even under single-phase load conditions.

Characteristics of the Tmax electronic trip units

Operating temperature	-13 °F...+158 °F (-25 °C...+70 °C)
Relative humidity	98%
Self-supply	0.2 x In (single phase)
Auxiliary power supply (where applicable)	24 V DC
Operating frequency	45...66 Hz
Electromagnetic compatibility (LF and HF)	IEC 60947-2 Annex F

For Tmax T2, T4, T5 and T6 the protection trip unit consists of:

- 3 or 4 current sensors (current transformers)
- external current sensors (e.g. for the external neutral), when available
- a trip unit
- a trip coil (for T2 housed in the right slot, for T4, T5 and T6 integrated in the electronic trip unit).

For Tmax T7 the protection trip unit consists of:

- 3 or 4 current sensors (Rogowski coils and current transformers)
- external current sensors (e.g. for the external neutral)
- interchangeable rating plug
- a trip unit
- a trip coil housed in the body of the circuit breaker.

Rating plugs

Circuit breaker	CS Rated current I _n	In [A]				
		400	600	800	1000	1200
T7	1000	■	■	■	■	
	1200	■	■	■	■	■

The current sensors supply the electronic trip unit with the energy needed for correct operation of the trip unit and the signal needed to detect the current.

The current sensors are available with rated primary current as shown in the table.

Current sensors

	In [A]	25	60	100	150	250	300	400	600	800	1000	1200
PR221DS	T2	■	■	■	■							
	T4			■	■	■	■					
	T5						■	■	■			
	T6								■	■		
PR222DS/P, PR222DS/PD-A	T4			■	■	■	■					
	T5						■	■	■			
	T6								■	■		
PR231/P, PR232/P, PR331/P, PR332/P	T7							■	■	■	■	■

When a protection function trips, the circuit breaker opens by means of the trip coil, which changes the contact AUX-SA (supplied on request, see chapter "Accessories" at page 3/21 and following) to tripping. Mechanical signalling reset takes place with resetting of the circuit breaker.

Power distribution circuit breakers

Electronic trip units

Basic protection functions



(L) Protection against overload

This protection function trips when there is an overload with inverse long-time delay trip according to an inverse time curve ($I^2t=k$). The protection cannot be excluded.



(S) Protection against short-circuit with time delay

This protection function trips when there is a short-circuit, with long inverse time-delay trip ($I^2t=k$ ON) or a constant trip time ($I^2t=k$ OFF). The protection can be excluded.



(I) Instantaneous protection against short-circuit

This protection function trips instantaneously in case of a short-circuit. The protection can be excluded.



(G) Protection against ground fault

The protection against ground fault trips when the vectorial sum of the currents passing through the current sensors exceeds the set threshold value, with long inverse time-delay trip ($I^2t=k$ ON) or a constant trip time ($I^2t=k$ OFF). The protection can be excluded.

2

Advanced protection functions

The PR332/P trip unit makes it possible to carry out highly developed protection against the most varied types of fault. It adds the following advanced protection functions to the basic protection functions.



(U) Protection against unbalanced phase

The protection function against unbalanced phase U can be used in those cases where a particularly precise control is needed regarding missing and/or unbalance of the phase currents. The trip time is instantaneous. The protection can be excluded.



(OT) Protection against overtemperature

The protection against overtemperature trips instantaneously when the temperature inside the trip unit exceeds 85 °C, in order to prevent any temporary or continual malfunction of the microprocessor. The protection cannot be excluded.



(ZS) Zone selectivity

ZS zone selectivity is an advanced method for carrying out coordination of the protections in order to reduce the trip times of the protection closest to the fault in relation to the time foreseen by time selectivity. Zone selectivity can be applied to the protection functions S and G, with constant time-delay trip. The protection can be excluded.



(UV, OV, RV) Protections against voltage

The three protections trip with a constant time-delay in the case of undervoltage, overvoltage and residual voltage respectively. The latter allows to detect interruptions of the neutral (or of the ground conductor in systems with grounded neutral). The protections can be excluded.



(RP) Protection against reversal of power

The protection against reversal power causes tripping of the breaker, with constant time-delay trip, when the flow of power reverses sign and exceeds, as an absolute value, the set threshold. It is particularly suitable for protection of large machines such as generators. The protection can be excluded.





(UF, OF) Protections of frequency

The two protections detect the variation in network frequency above or below the adjustable thresholds, opening the circuit breaker, with constant time-delay trip. The protection can be excluded.

Electronic trip units for power distribution

SACE PR221DS		
	PR221DS	PR221DS
Protection functions	L S / I	I

SACE PR222DS/P		
	PR222DS/P	PR222DS/P
Protection functions	L S I	L S I G

SACE PR222DS/PD-A		
	PR222DS/PD-A	PR222DS/PD-A
Protection functions	L S I	L S I G

2

PR222DS/P, PR222DS/PD-A – Protection functions and settings

Protection functions

L
CANNOT BE EXCLUDED

Against overload with long inverse time delay trip and trip characteristic according to an inverse time curve ($I^2t=constant$)



Trip threshold

Manual setting

$I_1 = 0.40 - 0.42 - 0.44 - 0.46 - 0.48 - 0.50 - 0.52 - 0.54 - 0.56 - 0.58 - 0.60 - 0.62 - 0.64 - 0.66 - 0.68 - 0.70 - 0.72 - 0.74 - 0.76 - 0.78 - 0.80 - 0.82 - 0.84 - 0.86 - 0.88 - 0.90 - 0.92 - 0.94 - 0.96 - 0.98 - 1 \times I_n$

Electronic setting

$I_1 = 0.40 \dots 1 \times I_n$ (step 0.01 $\times I_n$)

Release between 1.1...1.3 $\times I_1$
(IEC 60947-2 and UL 489)

Trip curves⁽¹⁾

Manual setting

at 6 $\times I_1$ $t_1 = 3s$ at 6 $\times I_1$ $t_1 = 6s$ at 6 $\times I_1$ $t_1 = 9s$ at 6 $\times I_1$ $t_1 = 18s^{(2)}$

Electronic setting

at 6 $\times I_1$ $t_1 = 3 \dots 18s$ (step 0.5s)⁽²⁾

Tolerance: $\pm 10\%$

S
CAN BE EXCLUDED

Against short-circuit with inverse short time delay trip and trip characteristic with inverse time ($I^2t=constant$) or definite time



Manual setting

$I_2 = 0.6 - 1.2 - 1.8 - 2.4 - 3.0 - 3.6 - 4.2 - 5.8 - 6.4 - 7.0 - 7.6 - 8.2 - 8.8 - 9.4 - 10 \times I_n^{(3)}$

Electronic setting

$I_2 = 0.60 \dots 10 \times I_n$ (step 0.1 $\times I_n$)⁽³⁾

Tolerance: $\pm 10\%$

Manual setting

at 8 $\times I_n$ $t_2 = 0.05s$ at 8 $\times I_n$ $t_2 = 0.1s$ at 8 $\times I_n$ $t_2 = 0.25s$ at 8 $\times I_n$ $t_2 = 0.5s$

Electronic setting

at 8 $\times I_n$ $t_2 = 0.05 \dots 0.5s$ (step 0.01s)

Tolerance: $\pm 10\%$ ⁽⁴⁾

$I^2t=const$ ON



Manual setting

$I_2 = 0.6 - 1.2 - 1.8 - 2.4 - 3.0 - 3.6 - 4.2 - 5.8 - 6.4 - 7.0 - 7.6 - 8.2 - 8.8 - 9.4 - 10 \times I_n^{(3)}$

Electronic setting

$I_2 = 0.60 \dots 10 \times I_n$ (step 0.1 $\times I_n$)⁽³⁾

Tolerance: $\pm 10\%$

Manual setting

$t_2 = 0.05s$ $t_2 = 0.1s$ $t_2 = 0.25s$ $t_2 = 0.5s$

Electronic setting

$t_2 = 0.05 \dots 0.5s$ (step 0.01s)

Tolerance: $\pm 10\%$ ⁽⁴⁾

$I^2t=const$ OFF

I
CAN BE EXCLUDED

Against short-circuit with instantaneous trip



Manual setting

$I_3 = 1.5 - 2.5 - 3 - 4 - 4.5 - 5 - 5.5 - 6.5 - 7 - 7.5 - 8 - 9 - 9.5 - 10.5 - 12 \times I_n^{(3)}$

Electronic setting

$I_3 = 1.5 \dots 12 \times I_n$ (step 0.1 $\times I_n$)⁽³⁾

Tolerance: $\pm 10\%$

instantaneous

G
CAN BE EXCLUDED

Against ground fault with inverse short time delay trip and trip characteristic according to an inverse time curve ($I^2t=constant$)



Manual setting

$I_4 = 0.2 - 0.25 - 0.45 - 0.55 - 0.75 - 0.8 - 1 \times I_n$

Electronic setting

$I_4 = 0.2 \dots 1 \times I_n$ (step 0.01 $\times I_n$)

Tolerance: $\pm 10\%$

Manual setting

up to 3.15 $\times I_4$ $t_4 = 0.1s$ up to 2.25 $\times I_4$ $t_4 = 0.2s$ up to 1.6 $\times I_4$ $t_4 = 0.4s$ up to 1.10 $\times I_4$ $t_4 = 0.8s$

Electronic setting

$t_4 = 0.1 \dots 0.8 \times I_n$ (step 0.01s)

Tolerance: $\pm 20\%$

⁽¹⁾ These tolerances hold in the following conditions:
- self-powered relay at full power and/or auxiliary supply;
- two or three-phase power supply.
In conditions other than those considered, the following tolerances hold:

	Trip time
S	$\pm 20\%$
G	$\pm 20\%$

⁽²⁾ For T5 $I_n = 600 A \Rightarrow t_1 = 10.5s$
⁽³⁾ For T5 $I_n = 600 A \Rightarrow I_{1,max} = 9.5 \times I_n$
 $I_{2,max} = 9.5 \times I_n$
⁽⁴⁾ Tolerance: $\pm 10 ms$ up to $t_2 = 0.1s$

Accessories

Service releases

Undervoltage release – UVR (UL FILE: E116596)

The undervoltage release opens the circuit breaker due to lack of release power supply voltage or due to values under $0.7 \times U_n$ with a trip range from 0.7 to $0.35 \times U_n$. After tripping, the circuit breaker can be closed again with a voltage higher than $0.85 \times U_n$. With the undervoltage release de-energised, it is not possible to close the circuit breaker or the main contacts.

UVR - Electrical characteristics

Power consumption during permanent operation

Version	Tmax T1, T2, T3		Tmax Ts3		Tmax T4, T5, T6		Tmax T7	
	AC [VA]	DC [W]	AC [VA]	DC [W]	AC [VA]	DC [W]	AC [VA]	DC [W]
24 V AC/DC			6	3			3.5	3.5
24...30 V AC/DC	1.5	1.5			6	3		
30 V AC/DC							3.5	3.5
48 V AC/DC	1	1	6	3	6	3		
60 V AC/DC	1	1			6	3		
110...120 V AC/DC			6				3.5	3.5
120...127 V AC/DC							3.5	3.5
110...127 V AC-110...125 V DC	2	2			6	3		
220...240 V AC/DC							3.5	3.5
220...240 V AC-220...250 V DC	2.5	2.5		3	6	3		
220...250 V AC			6					
240...250 V AC/DC							3.5	3.5
380...400 V AC							3.5	
380...440 V AC	3				6			
415...440 V AC							3.5	
480 V AC			6					
480...525 V AC	4				6			
Opening times [ms]	15	15	≤ 18	≤ 18	≤ 25	≤ 25	≤ 25	≤ 25

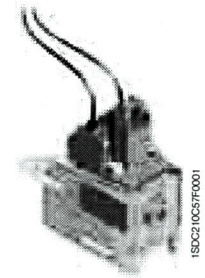

T1-T2-T3

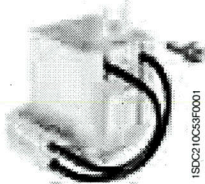

T4-T5-T6

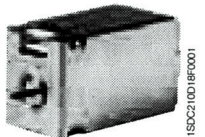

T7

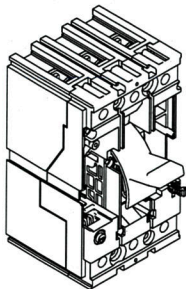

T1-T2-T3

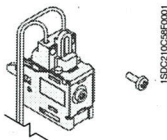

Ts3

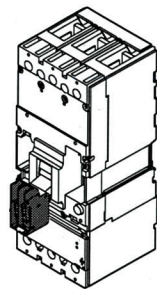

T4-T5-T6

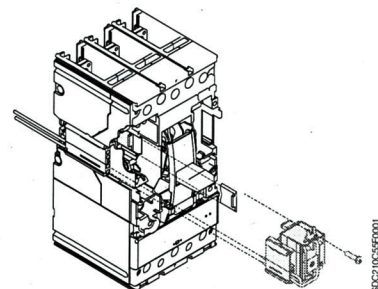

Accessories

Electrical signals

These allow information on the operating state of the circuit breaker to be real outside.

Installation of these accessories is carried out directly from the front of the circuit breaker in special slots placed on the right-hand side of the circuit breaker, completely segregated from the live parts - all to the benefit of user safety. The auxiliary contacts can be supplied (depending on the type) either with cabling directly on the circuit breaker terminal board or in the pre-cabled version, depending on the size of the circuit breaker fitted with free cables 39.4" (1 m) long, with a connector with 39.4" (1 m) long cables. The pre-cabled version is mandatory on the T4, T5 and T6 circuit breakers in the draw out version. The auxiliary contacts for T7 are always fitted with three terminals to be mounted in the terminal board to carry out the cabling. The auxiliary contacts are available for use both in direct and alternating current at various voltages. The signals are reset when the circuit breaker is reset.



AUX - 250 V AC/DC

1SDC210023F0001



AUX-C - 250 V AC/DC

1SDC210023F0001



T7

1SDC210019F0001

T1-T7 (AUX)

Available both in the pre-cabled and uncabled version, auxiliary contacts supply the following electrical signalling:

- Form C (open/closed): indicates the position of the circuit breaker contacts (Q)
- Bell alarm: signals circuit breaker opening due to overcurrent release trip (for overload or short circuit), trip of the residual current release, of the opening coil or of the undervoltage release, of the emergency opening pushbutton of the motor operator or two to operation of the test pushbutton (SY)
- Contact for signalling electronic trip unit tripped: signals intervention of one of the protection functions of the electronic trip unit (S51) (except for Ts3).

The auxiliary contacts for T7 are always fitted with terminals to be mounted in the terminal box to carry out wiring.

T4, T5, T6 and T7 with electronic trip units (AUX-SA)

There is a contact for signalling electronic trip units tripped, only available in the pre-cabled version for use at 250 V AC.

T4, T5 and T6 (AUX-MO)

This auxiliary contact, only in the uncabled version, must be combined with the motor operator and indicates the motor operation mode (manual or remote).

T7 (AUX-RTC)

The "circuit breaker ready to close" auxiliary contact is available with wiring directly on the terminal box of the stored energy T7 circuit breaker and signals that the circuit breaker is ready to accept a closing command if there are the following five conditions:

- circuit breaker open
- closing springs charged
- any opening coil de-energised
- any undervoltage coil energised
- opening solenoid armed.

T7 (AUX-SC)

Remotely indicates the state of the circuit breaker operating mechanism is closing springs (supplied only with the spring charging motor).

Accessories

Remote control

Stored energy motor operator for T4, T5 and T6 – MOE and MOE-E (UL FILE: E116596)

With the stored energy motor operator, it is possible to control both opening and closing of the circuit breaker on which it is installed. During opening of the circuit breaker, the spring system is recharged automatically: the stored energy is exploited in this way to close the circuit breaker.

The motor operator is always supplied with socket-plug connectors with 39.4" (1 m) long cables and is always fitted with a padlock in the open position, which prevents any command, either locally or remotely. The connectors, once inserted in the special slot on the left-hand side of the circuit breaker, extend out of the outline of the circuit breaker itself and are only compatible with pre-wired electrical accessories. A selector allows passage from automatic to manual operation and a block is also available (supplied as standard) for the operating mode of the motor.

The motor operator can be fitted both with a key lock in the open position (with the same MOL-S keys for groups of circuit breakers or different MOL-D keys) and with an MOL-M key lock against manual operation: in the former case, the lock in the open position is both of electrical and mechanical type, in the latter case, only of mechanical type, i.e. only closing from the front of the circuit breaker (remote closing is allowed). In the case of interlocked circuit breakers, for safety reasons the key lock against manual operation is required.

The motor operator is always fitted with a contact to signal "auto" or "manual" (not on changeover). On request, it can also be fitted with an AUX-MO auxiliary contact (on changeover), which provides a signal of its state of service: "auto" (remote control of the circuit breaker) or "manual".

If the circuit breaker is fitted with the PR222DS/PD-A electronic trip unit, instead of the MOE motor operator, it is possible to use the MOE-E motor operator: for its use, the circuit breaker must also be fitted with the AUX-E auxiliary contacts (standard supply with MOE-E). The MOE-E allows use of the digital signals coming from the supervision and control system, by means of the PR222DS/PD-A and the AUX-E contacts, and to convert these into power signals to operate the motor operator. All the characteristics indicated above for the MOE motor operator are also valid for the MOE-E.

The main parameters relative to the stored energy motor operator are indicated in the table.

MOE and MOE-E

	Tmax T4-T5		Tmax T6	
	AC [V]	DC [V]	AC [V]	DC [V]
Rated voltage, Un	-	24	-	24
	-	48...60	-	48...60
	110...125	110...125	110...125	110...125
	220...250	220...250	220...250	220...250
	380	-	380	-
Operating voltage [% Un]	85...110	85...110	85...110	85...110
Power consumption on inrush Ps	≤ 300 VA	≤ 300 W	≤ 400 VA	≤ 400 W
Power consumption in service Pc	≤ 150 VA	≤ 150 W	≤ 150 VA	≤ 150 W
Duration	opening [s]	1.5	3	
	closing [s]	< 0.1	< 0.1	
	resetting [s]	3	5	
Mechanical life [no. Operations]	20000		10000	
Degree of protection, on the front	IP30		IP30	
Minimum control impulse time on opening and closing [ms]	≥100		≥100	

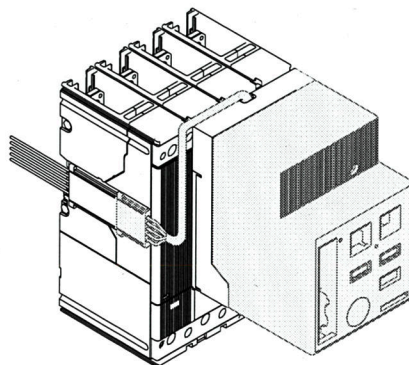

1SDC210079F0001

1SDC210079F0001

Trip curves for power distribution

Circuit breakers with electronic trip units

T4 250 / T5 400/600 – PR221DS

L-S Functions

Note: For T5 In = 600 A ⇒ I_{2max} = 9.5 x In

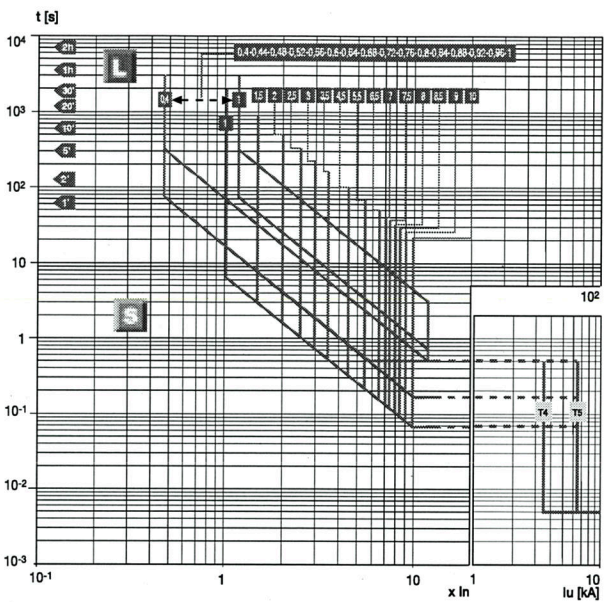

1SDC210023P0001

T4 250 / T5 400/600 PR222DS/P and PR222DS/PD-A

L-S-I Functions (I²t const = ON)

Note: For T5 In = 600 A ⇒ I_{2max} = 9.5 x In, I_{3max} = 9.5 x In

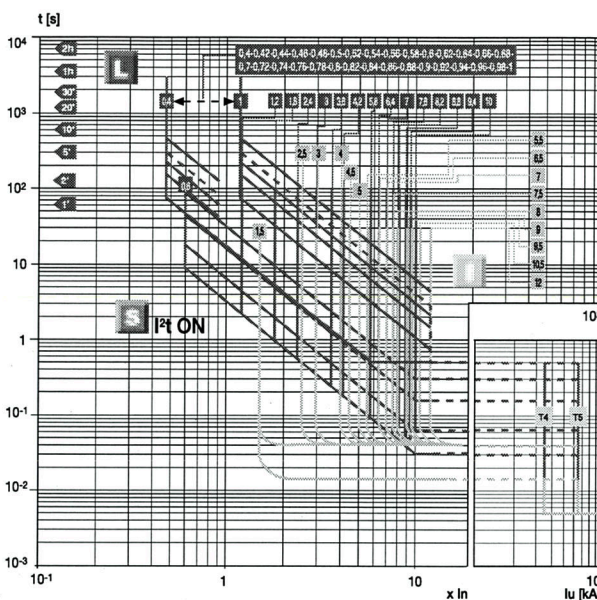

1SDC210023P0001

4

T4 250 / T5 400/600 PR222DS/P and PR222DS/PD-A

L-S-I Functions (I²t const = OFF)

Note: For T5 In = 600 A ⇒ I_{2max} = 9.5 x In, I_{3max} = 9.5 x In

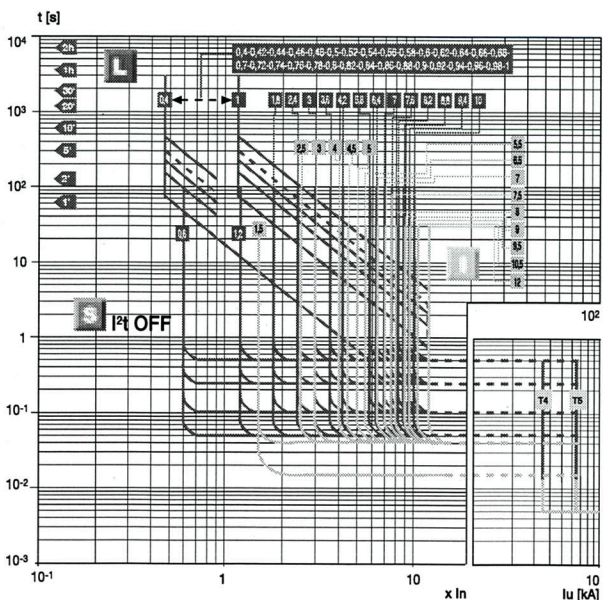

1SDC210023P0001

T4 250 / T5 400/600 PR222DS/P and PR222DS/PD-A

G Function

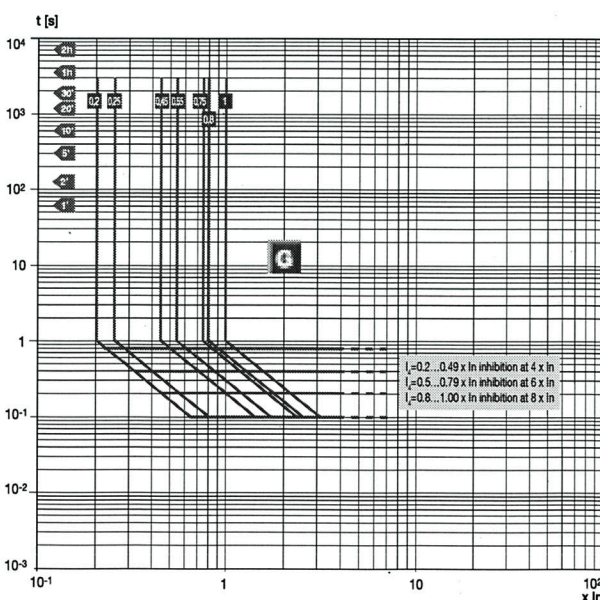

1SDC210023P0001

Tmax Ts3 150

In [A]	50 °F / 10 °C	68 °F / 20 °C	86 °F / 30 °C	104 °F / 40 °C	122 °F / 50 °C	140 °F / 60 °C
15	18	17	16	15	14	13
20	24	22	21	20	19	17
25	30	28	27	25	23	21
30	35	33	32	30	28	26
35	41	39	37	35	33	30
40	47	44	42	40	37	34
50	59	56	53	50	47	43
60	71	67	64	60	56	51
70	83	78	74	70	66	60
80	94	90	85	80	75	68
90	106	101	95	90	85	77
100	118	112	106	100	95	85
125	148	140	133	125	119	106
150	177	168	159	150	143	127

Tmax Ts3 225

In [A]	50 °F / 10 °C	68 °F / 20 °C	86 °F / 30 °C	104 °F / 40 °C	122 °F / 50 °C	140 °F / 60 °C
175	207	196	186	175	166	149
200	236	224	212	200	190	170
225	266	252	239	225	214	191

Tmax T4

In [A]	50 °F / 10 °C	68 °F / 20 °C	86 °F / 30 °C	104 °F / 40 °C	122 °F / 50 °C	140 °F / 60 °C
20	24	22	21	20	19	17
25	30	28	27	25	23	21
40	47	44	42	40	37	34
50	59	56	53	50	47	43
80	94	90	85	80	75	68
100	118	112	106	100	95	85
125	148	140	133	125	119	106
150	177	168	159	150	143	127
200	236	224	212	200	190	170
250	266	252	239	225	214	191

Tmax T5 400/600

In [A]	50 °F / 10 °C	68 °F / 20 °C	86 °F / 30 °C	104 °F / 40 °C	122 °F / 50 °C	140 °F / 60 °C
300	241...345	230...328	220...314	210...300	200...286	187...267
400	325...465	310...442	295...420	280...400	265...380	250...355
600	483...690	459...656	440...628	420...600	400...572	374...534

Tmax T6 800

In [A]	50 °F / 10 °C	68 °F / 20 °C	86 °F / 30 °C	104 °F / 40 °C	122 °F / 50 °C	140 °F / 60 °C
600	520...740	493...705	462...660	441...630	405...580	380...540
800	685...965	640...905	605...855	560...800	520...740	470...670