

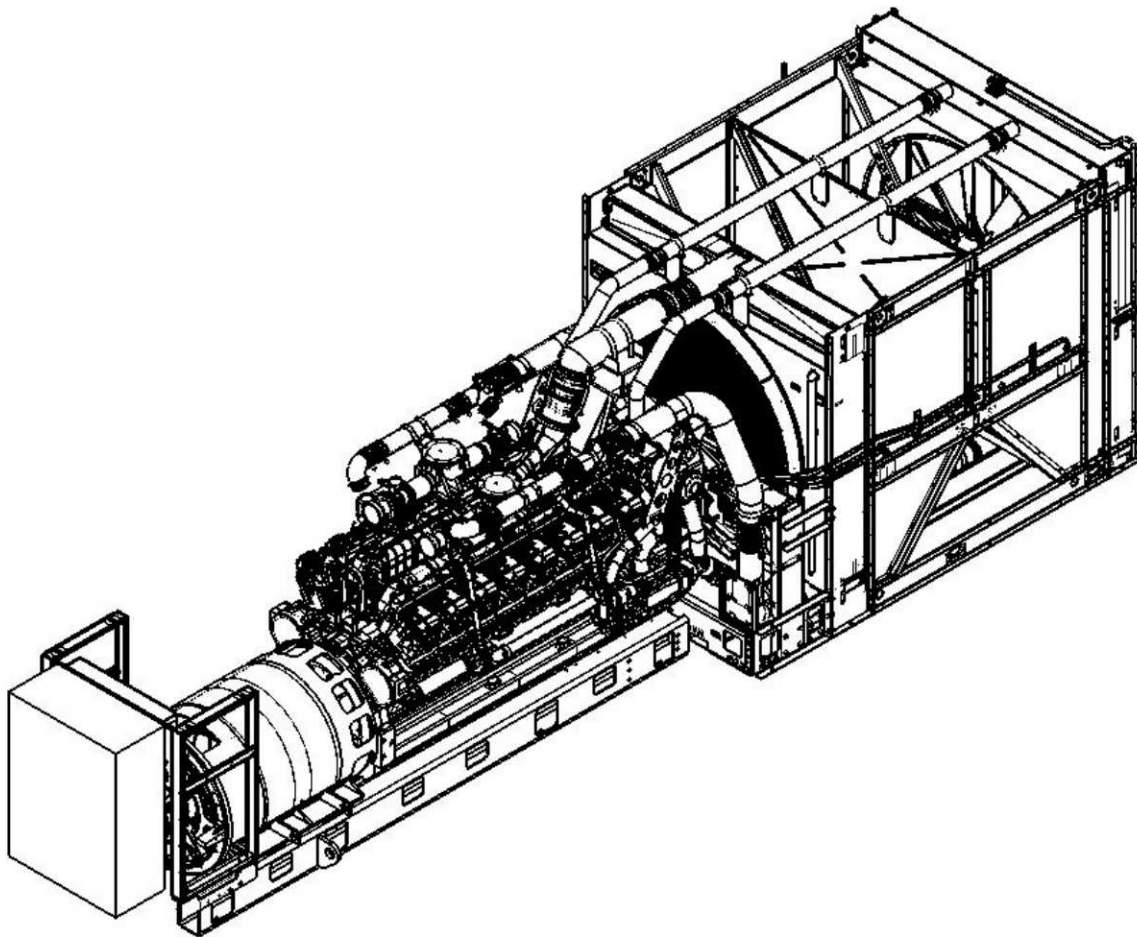

INSTALLATION, OPERATION AND MAINTENANCE MANUAL FOR Engine Mounted Radiators with Extended Shafts



9625 55TH Street
Kenosha, WI 53144
Telephone (262) 942-1414
Fax (262) 942-1410
Toll Free (800) 919-9559
Website www.iearad.com
Email sales@iearad.com

LIMITED WARRANTY

IEA, LLC ("IEA") warrants that Radiators and Components sold to Buyer (the "Products") shall meet performance or print specifications as stated in the IEA quote or Buyer-approved drawings. IEA warrants all Products manufactured or sourced by IEA and furnished to Buyer to be free from defects in material and workmanship under normal use and service.

The warranty period continues until the first to occur of 1) one year from date of installation or 2) eighteen months from the date of shipment from IEA.

Non-conforming Product covered by this Limited Warranty will be repaired or replaced by IEA provided that the subject Product was installed and maintained according to IEA's Installation and Operation Manual.

Buyer shall afford IEA the opportunity to utilize IEA Field Service technicians for all warranty or potential warranty claims or issues. When IEA technicians are not utilized, Product components identified as causing the warranty claim and therefore replaced must be returned to IEA for analysis or, if the Product is repaired rather than replaced, then acceptable digital pictures must be provided for warranty claim authorization.

IEA values its program of continuous improvement and therefore reserves the right to improve its products through changes in Product design or materials at its discretion without obligation to incorporate such changes in products it previously manufactured.

This warranty does not warrant against corrosion of radiators or components nor against damage caused by vibration.

Buyer's sole and exclusive claim under this Limited Warranty is the repair or replacement, at IEA option and expense, of the non-conforming Product or components thereof.

IEA warranties extend only to Buyer and are not assignable to, or assumable by, any subsequent purchaser, in whole or in part. Any such attempted transfer shall render all warranties provided hereunder null and void and of no further force or effect.

The warranties set forth are inapplicable to and exclude any defect, damage, or malfunction resulting from (i) normal wear and tear, (ii) misuse, negligence, or modification of the Product, (iii) repair service provided by third parties not approved in advance by IEA (iv) failure by Buyer to follow IEA installation and operation manuals or instructions, (v) failure of parts or components or services not provided by IEA or (vi) any other cause outside IEA's reasonable control.

The Warranties set forth above are in lieu of all other warranties, express or implied, including but not limited to any implied warranty of merchantability or fitness for a particular purpose.

FORM #001: 9-21-12
SUPERSEDES: 5-20-10

TABLE OF CONTENTS

<u>Sections</u>	<u>Page</u>
1. SAFETY INSTRUCTIONS.....	5
1.1 Safe Operating Practices	5
1.2 Graphics Descriptions	5
1.3 Coolant and Fuel Cooler Connections	5
1.4 Safety Attire	6
2. MANUAL SCOPE	6
3. RADIATOR DESCRIPTION & APPLICATION	6
4. PRE INSTALLATION.....	8
4.1 Receiving and Inspection	8
4.2 Storage	8
4.3 Transporting and Lifting.....	8
4.4 Pre-Installation Procedure.....	9
5. INSTALLATION	10
5.1 General Installation Process	10
5.2 Piping General Guidelines.....	10
5.3 Coolant Connection Installation.....	11
5.4 Deaeration System Considerations.....	11
5.5 Liquid Level Alarms	12
6. OPERATION.....	12
6.1 Optional Jacket Water Air Pressure Decay Leak Test.....	12
6.2 System Filling	13
6.3 System Venting	13
6.4 Final Unit Inspection.....	13
6.5 Initial Run.....	13
7. Appendix I Reference Tables	14
8. Appendix II Maintenance Requirements.....	15
9. Appendix III Fan Drive Installation and Belt Tensioning.....	17
Step 1: Remove all front and side belt guards.....	17
Step 2: Install radiator per drawing	17
Step 3: Align drive sheave to driven sheave.....	18
Step 4: Install belt.....	19
Step 5: Place tensioner in working location	19
Step 6: Extend tensioner to tension belt	20
Step 7: Install belt guard	20



Figures

Figure 1: General Installation Overview	6
Figure 2: Primary components of radiator	7
Figure 3: Lifting Provisions	9
Figure 4: Jacket Water Flow direction (typical).....	10
Figure 5: After Cooler Flow direction (typical)	11
Figure 6: Liquid Level Alarm installation.....	12
Figure 7: Condensate Drain location	16
Figure 8: Nameplate location and diagram.....	16
Figure 9: Guard parts to remove	17
Figure 10: Radiator installation.....	18
Figure 11: Sheave alignment.....	18
Figure 12: Tensioner in shipping position.....	19
Figure 13: Tensioner in installed position	19
Figure 14: Tensioner nomenclature.....	20
Figure 15: Dimension to take to tension belt	20

Tables

Table 1: Engine Mounted Radiator limitations.....	14
Table 2: Bolt Torque Values	14
Table 3: Bushing Torque Values	14
Table 4: Maintenance Schedule	15
Table 5: Lubrication Frequency	15
Table 6: Fan Drive Installation Resource Table	17
Table 7: Fan Drive Installation Steps.....	17







1. SAFETY INSTRUCTIONS

NOTE: Read this Operator's Manual carefully. Follow all safety precautions and operating recommendations to ensure safe and trouble free operation of the radiator.

1.1 Safe Operating Practices

- 1.1.1 The radiator has unique weight and balance characteristics. Before interacting with the radiator, become familiar with it.
- 1.1.2 Observe all safety laws and regulations applicable to the area of operation.
- 1.1.3 Replace any safety decals that become damaged or illegible. Contact IEA directly to order replacement decals.
- 1.1.4 Any modifications to the radiator that are not performed by, or under the guidance of authorized IEA personnel could affect the safety, performance or durability of the radiator. If problems result, this may violate local regulations, and/or service may not be covered under the warranty.
- 1.1.5 To ensure safe and trouble free operation, always purchase genuine IEA replacement parts from IEA directly. Using replacement parts from other sources may void the warranty.
- 1.1.6 To prevent bodily harm, it is the responsibility of the end user to fully insulate all hot surfaces.
- 1.1.7 To avoid back injury, use lifting aids (i.e. forklift, crane, chain pull, etc.) whenever shifting, adjusting, moving, mounting or otherwise manipulating any components of or the radiator as a whole.
- 1.1.8 **WARNING: Over pressurization of product can result in premature product failure, engine damage and potential harm to standers-by. Refer to Table 1 for safe operating limits.**
- 1.1.9 **NEVER INSTALL OR MAINTENANCE DURING ENGINE OPERATION!**

1.2 Graphics Descriptions

Graphic	Description
	Lift Point: Recommended lifting location
	Do not lift point: Lifting from this location may injure worker or damage equipment.
	Warning: Physical harm to worker or damage to equipment may occur if step is not followed.
	Note: Recommended course of action for less difficulty.
	Hot surface: This surface is hot during engine operation. Take care while working in this area during engine operation.

1.3 Coolant and Fuel Cooler Connections

- 1.3.1 Coolant and fuel lines can fail because of physical damage, age, vibration and exposure to extreme environments. Check and tighten hoses, lines and connections regularly and replace them if necessary.
- 1.3.2 Ensure all hose clamps are installed and functional before, during and after operation.
- 1.3.3 Ensure all lines are free from obstruction, crossover or physical contact with other lines in the system.

1.4 Safety Attire

Whenever working with the radiator:

- 1.4.1 Consult and comply with local and site specific safety guidelines.
- 1.4.2 Wear safety glasses and hearing protection.
- 1.4.3 Wear sturdy footwear that fully covers feet.
- 1.4.4 Wear protective gloves to protect against burns and cuts.

2. MANUAL SCOPE

- 2.1 This manual is provided to assist customers in the installation, operation, and maintenance of engine mounted radiators with charge air coolers and extended shafts (ECCX series).
- 2.2 This manual pertains to the installation, operation and assembly of the radiator only. Please refer to supplied drawings or customer service for instructions pertaining to accompanying components (i.e. containment clamps, coolant connections, etc.).
- 2.3 ECCX series radiators require additional components such as a coolant and charge air connections, fan drives and guards. Coolant and charge air connections are covered in **Sections 5.2** and **5.3** and the fan drive is covered in **Appendix III**.

3. RADIATOR DESCRIPTION & APPLICATION

- 3.1 The ECCX series radiator is an engine mounted cooling unit used to cool high horsepower gensets. The jacket water (JW) and Air to Air After Cooler (ATAAC) fans are driven at the same speed via a common long shaft with a coupling. Below are two diagrams: **Figure 1**, a general installation overview and **Figure 2**, the primary components of the radiator.
- 3.2 The ECCX series radiator is designed to be installed into a HI CUBE shipping container. Refer to drawings provided for mounting provisions and radiator dimensions.

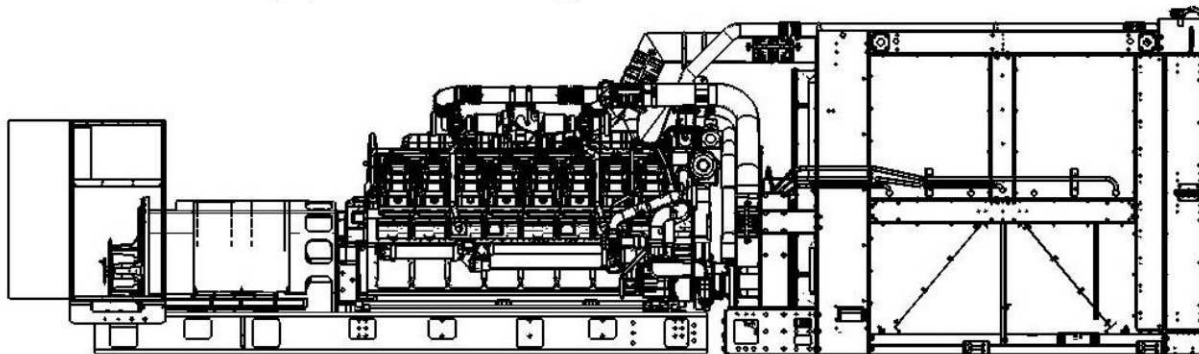

Figure 1: General Installation Overview

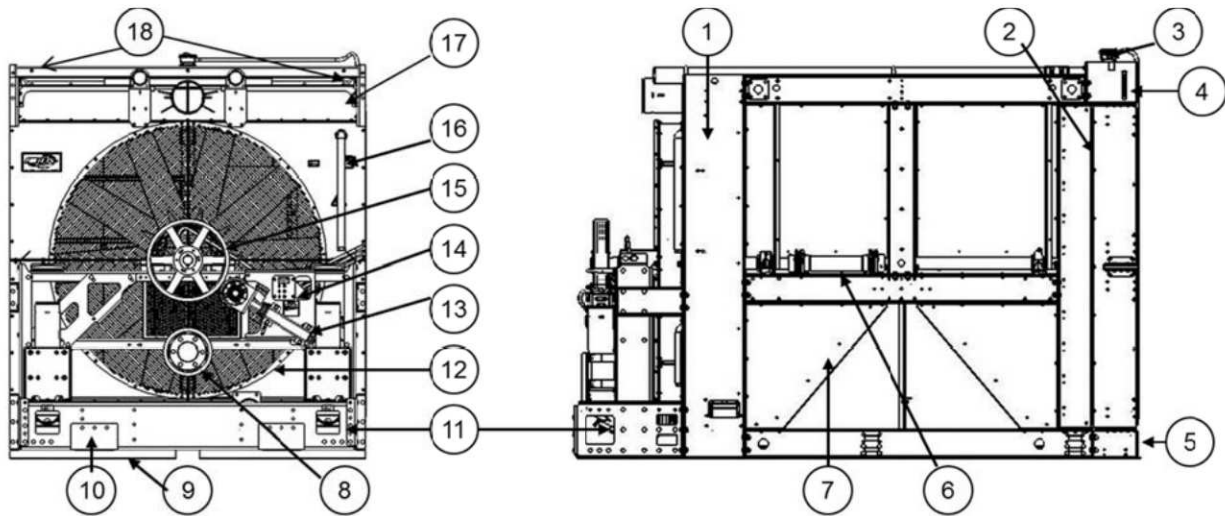

Figure 2: Primary components of radiator

Figure Legend

- 1 – Air to Air After Cooler circuit (ATAAC)
- 2 – Jacket Water circuit (JW)
- 3 – Bolt on JW filler neck
- 4 – JW sight glass
- 5 – JW Drain (middle of bottom JW tank)
- 6 – Coupling
- 7 – Service Access Panel (x3)
- 8 – Engine Sheave
- 9 – Floor Mounted Air Baffle (x2)
- 10 – Fork Pocket Covers (x4, JW and ATAAC sides)
- 11 – ATAAC Condensation Drains
- 12 – Fan Guard
- 13 – Tensioner
- 14 – Grease lines
- 15 – Fan Sheave
- 16 – Fuel Cooler lines
- 17 – ¼" NPT coupling (for JW low coolant sensor)
- 18 – ¼" NPT couplings (for vents)

4. PRE INSTALLATION

4.1 Receiving and Inspection

4.1.1 Packing Slip & Bill of Lading

- 4.1.1.1 Check packing slip/bill of lading to verify all items have been received. Refer to supplied drawings for list of included parts.
- 4.1.1.2 Items not received that are on the packing slip shall be reported to carrier.
- 4.1.1.3 Items not on the packing slip that should have been received shall be reported to an IEA representative per contact info at the bottom of page.

4.1.2 Damage

- 4.1.2.1 Check radiator and/or accessories for deformation, dents, fractures or any other type of damage – particularly around the water connections.
- 4.1.2.2 Any damage must be noted on bill of lading before carrier's departure.
- 4.1.2.3 Report and file damage claim with carrier immediately.
- 4.1.2.4 IEA is not responsible for unreported damage.

4.1.3 Items Shipped with the radiator

- 4.1.3.1 Items shipped with the radiator (i.e. coolant connections and hump hoses) need to be installed during the mounting of the radiator. Keep them with the radiator at all times.
- 4.1.3.2 Installation instructions are located in **Section 5** and **Appendix III** of this manual.

4.2 Storage

- 4.2.1 Radiator **must** be stored under a weather resistant canopy or indoors.
- 4.2.2 Drain radiator of any coolant or other liquids and store dry.



Note: Gaskets shrink with time. When refilled, there may be tank to header leaks. Allow 48 hours for the gaskets to swell before tightening any bolts. **If the bolts are tightened prematurely the gaskets will be ruined and the radiator will require disassembly to replace the gaskets.**

- 4.2.3 Protect radiator from damage during moving, lifting and storing.
- 4.2.4 Ensure unit is secured from falling or collision during moving, lifting and storing.
- 4.2.5 Keep caps over ports, secured in place to protect the radiator from animals nesting in tubes.
- 4.2.6 Secure radiator accessories to shipping skid to avoid misplacement.
- 4.2.7 If stored for long period of time, complete all of the above as well as the following:
 - 4.2.7.1 Protect the radiator from weather, make sure any motor conduit boxes are covered or plugged to prevent water entry.
 - 4.2.7.2 Apply grease or preservative compound to the sheaves, exposed fan shaft and keyway.
 - 4.2.7.3 Grease bearings on fan shafts.
 - 4.2.7.4 Rotate the fan shaft 10-15 turns every 30 days.
 - 4.2.7.5 Treat the radiator internals in the same manner as recommended by engine manufacturer for the engine.
 - 4.2.7.6 Remove belts and store in cool, dry location.

4.3 Transporting and Lifting

- 4.3.1 Transport with forklift when possible. When using forklift, use forklift capable of radiator weight with forks long enough to support entire radiator.
- 4.3.2 Use proper hoisting equipment for the size and weight of the radiator.
- 4.3.3 Use the lift points provided (Refer to **Figure 3**).
- 4.3.4 **Do not lift radiator and engine together. Do not cantilever radiator off engine rails.**
- 4.3.5 Rapid movements while lifting will cause the radiator to become unstable.
- 4.3.6 Use tether lines to restrict radiator movement and help guide unit into position where required.
- 4.3.7 Use lifting points provided if using an overhead crane (Refer to **Figure 3**).
- 4.3.8 **CAUTION: DO NOT LIFT FROM WATER OR AIR CONNECTIONS.**

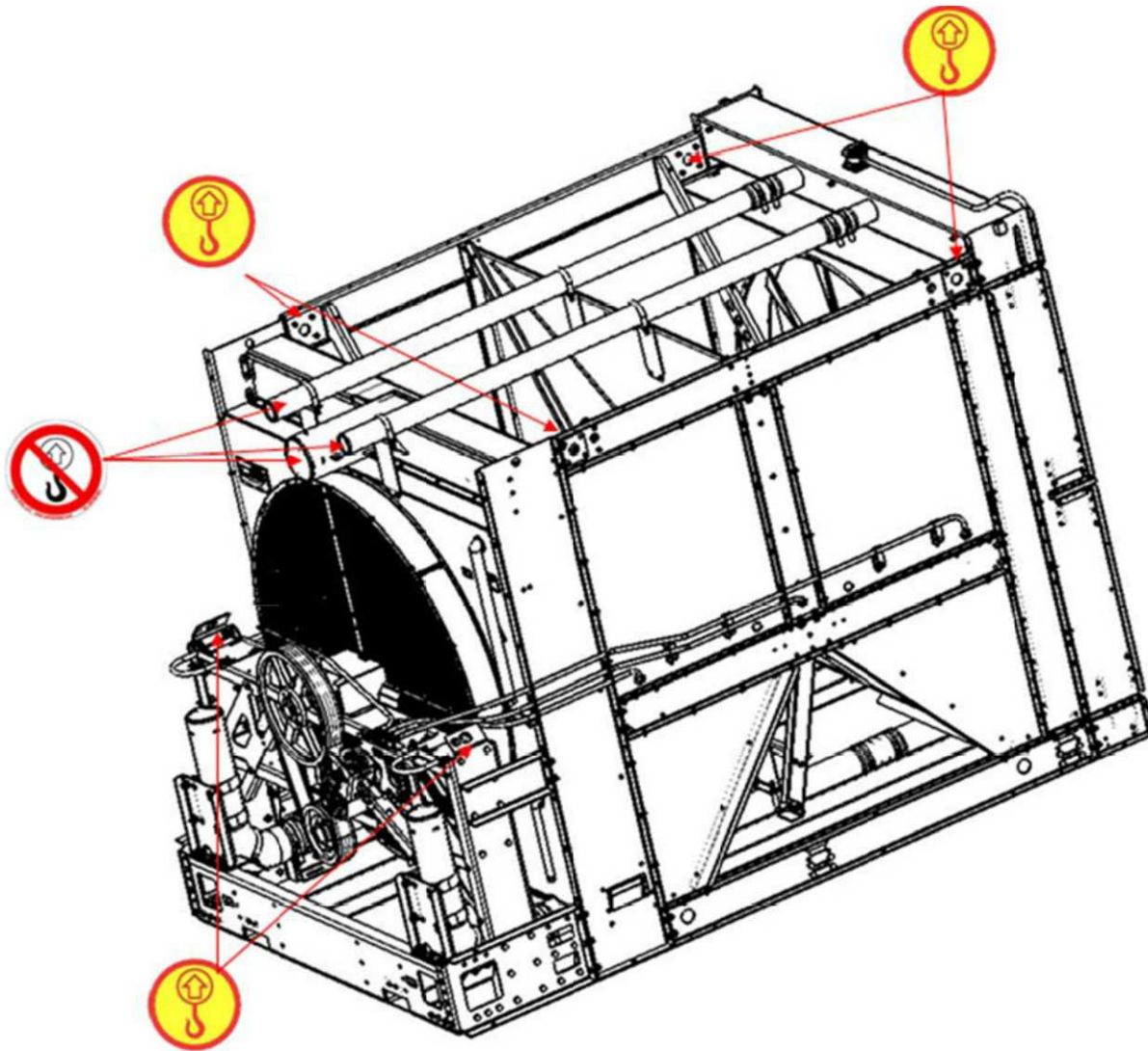

Figure 3: Lifting Provisions

4.4 Pre-Installation Procedure

- 4.4.1 Remove radiator and it's components from shipping container (Refer to **Section 4.1**).
- 4.4.2 Account for all ship loose items.
- 4.4.3 Clean all tubes, hoses, and pipes of any debris.
- 4.4.4 Drain radiator of any liquid.
- 4.4.5 **If radiator is mounted in hi-cube container, remove all bolts securing JW fillerneck and cover hole to prevent debris from getting into tank.**
- 4.4.6 Remove front and side belt guards.
- 4.4.7 Mount stub shaft per engine manufacturer's guidance.

5. INSTALLATION

5.1 General Installation Process

- 5.1.1 Locate and mount the radiator per installation drawing.
- 5.1.2 Loosen bolts holding floor mounted air baffles in place (Refer to **Figure 2**). Lower baffle so it is flush with floor. Mount baffle to floor.
- 5.1.3 Ensure all fork pocket covers are installed (two are below JW core, two are below ATAAC core).
- 5.1.4 Install fan drive and belt (Refer to **Appendix III**).
- 5.1.5 Install JW and ATAAC connection kits.
- 5.1.6 Connect fuel cooler lines.
- 5.1.7 Fill coolant per engine manufacturer's guidelines.

5.2 Piping General Guidelines

 **NOTE:** Plumbing varies by engine manufacturer and design requirements. Flow diagrams are for reference only (Refer to **Figures 4 and 5**).

- 5.2.1 All connecting components to the radiator need to be externally supported, not hung on radiator ports. Refer to drawings for connection supports provided.
- 5.2.2 Use flexible connections to isolate radiator from vibration, thermal growth or shock.
- 5.2.3 **Check all pipe internals for cleanliness. Remove debris before installing connections.**
- 5.2.4 Strainers or filters are recommended in JW coolant circuit for initial start-up to remove any debris inside engine or piping system.
- 5.2.5 When testing coolant connections for leaks, test at 2 psig below the pressure cap rating. **DO NOT EXCEED PRODUCT 25 PSIG.** Doing so may compromise integrity of the system.
- 5.2.6  **NOTE:** To prevent bodily harm, it is the responsibility of the end user to fully insulate all hot surfaces in the system.

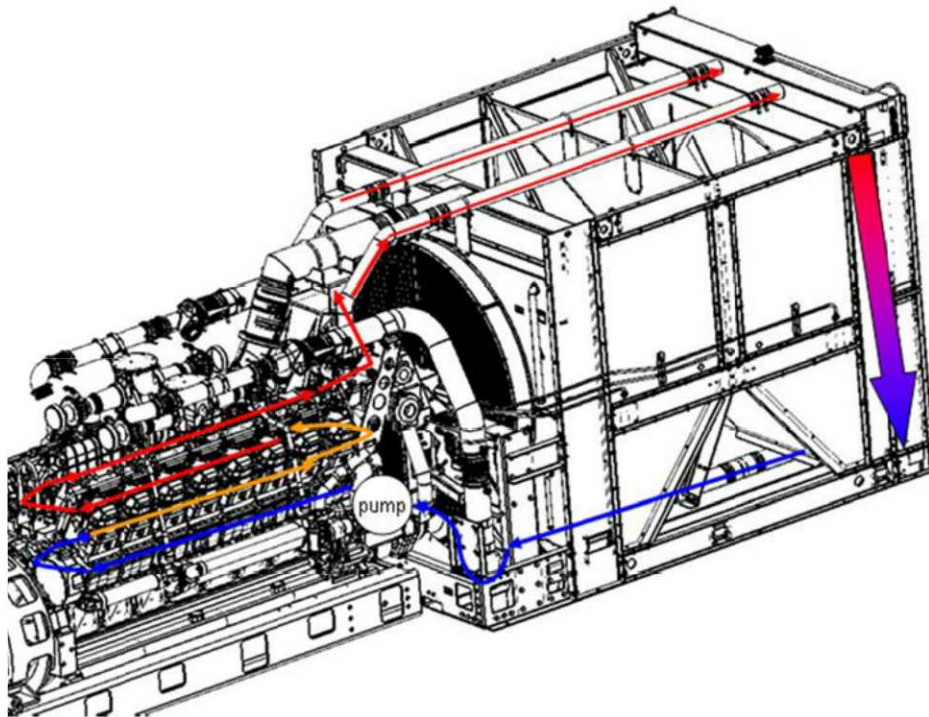

Figure 4: Jacket Water Flow direction (typical)

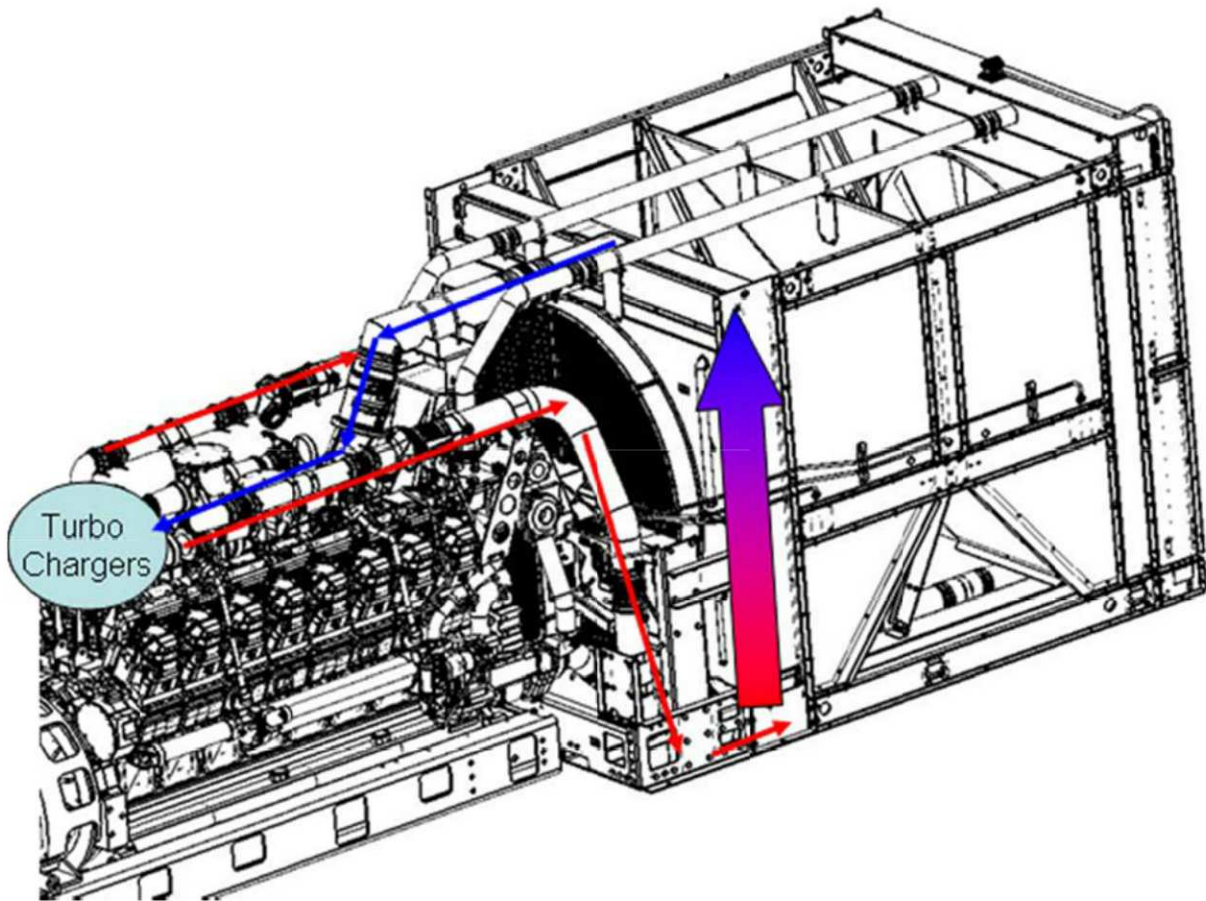



Figure 5: After Cooler Flow direction (typical)

5.3 Coolant Connection Installation

- 5.3.1 Plumb coolant connections per drawings provided, ensuring proper flow requirements are followed. (Refer to **radiator drawing and Figures 4 and 5**).
- 5.3.2 While connections can be installed in any order, best practice suggests installing connections from the top (highest point) to the bottom (lower points).
- 5.3.3 Align coolant fittings on radiator with coolant connections, loosely connecting all parts (so pipes are held in place but allow freedom of movement).
- 5.3.4 After all connections are in place, properly secure all pipes (so there is no freedom of movement and all fitting hardware is tightened to required torque specifications).
- 5.3.5 Properly support all coolant and charge air pipes. Refer to drawings for connection supports provided.
- 5.3.6 **DO NOT CANTILEVER ANY PLUMBING COMPONENTS ON COOLANT FITTINGS!** 

5.4 Deaeration System Considerations

- 5.4.1 Connection of a deaeration system shall be in accordance with engine manufacturer's recommendations.
- 5.4.2 A 3/4" to 1-1/2" line shall be plumbed from the radiator top tank to the engine water pump. Refer to **Figure 2** for JW vent line locations. For engines with separate jacket water and after cooler circuits, each top tank shall have lines plumbed to each water pump.
- 5.4.3 A 1/4" to 1/2" vent line from the engine thermostat housing to the radiator top tank is required.
- 5.4.4 Fast fill ports may be provided on models with deaerated tanks. This port is used to **INITIALLY FILL** the radiator.

5.5 Liquid Level Alarms

- 5.5.1 Radiators equipped with pre-alarm level gauges from IEA require no additional plumbing.
- 5.5.2 **Caution:** Pump cavitation can occur if additional alarms are installed at lower levels.
- 5.5.3 **Figure 6** shows low level alarm installation in a vertical radiator. The top connection is plumbed to the lowest acceptable coolant level in the radiator top tank. The lower connection is plumbed to the center of the radiator bottom tank (unless otherwise specified.)
- 5.5.4 **Figure 6** shows the wiring of the alarm system

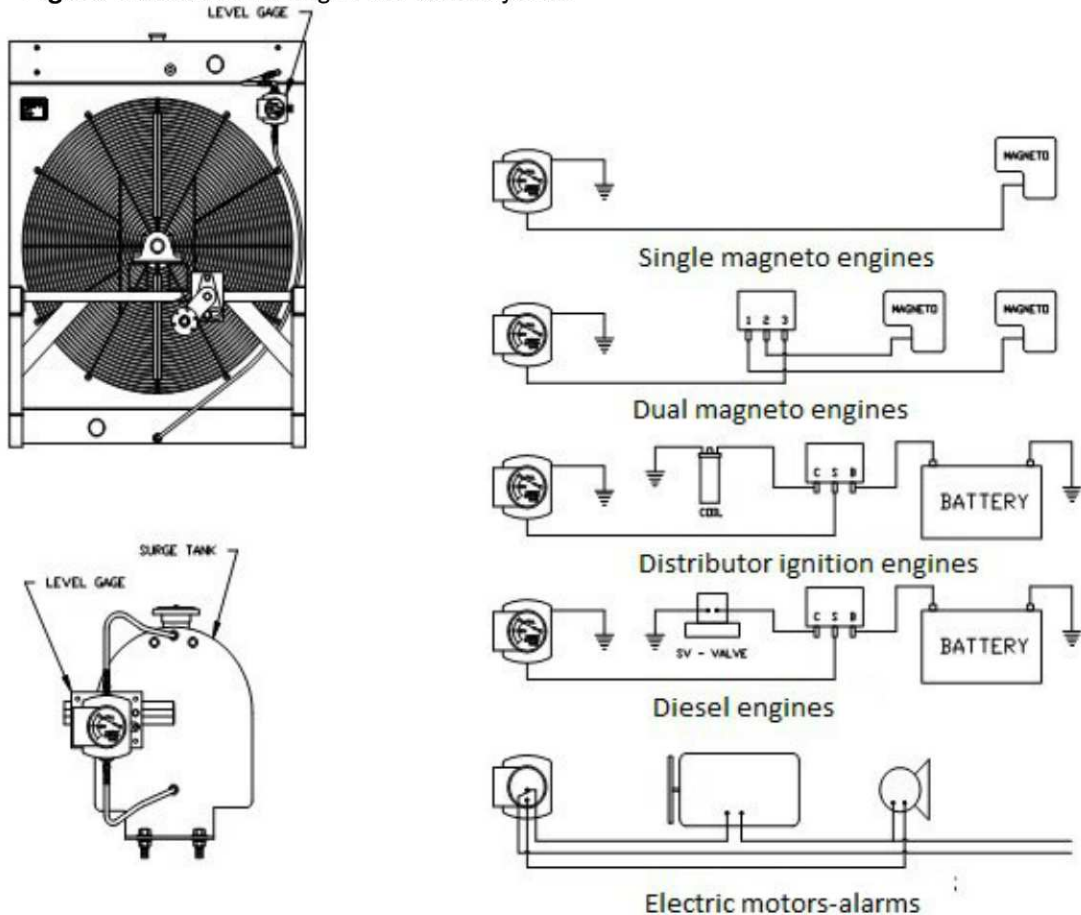

Figure 6: Liquid Level Alarm installation

6. OPERATION

6.1 Optional Jacket Water Air Pressure Decay Leak Test

NOTE: This test is used to ensure system is leak free prior to system filling.

- 6.1.1 Ensure all valves in system are set correctly (open or closed) for proper flow progression.
- 6.1.2 Fill with air to 2 psig below pressure cap rating. **DO NOT EXCEED 25 psig.**
- 6.1.3 Shut off air supply.
- 6.1.4 Measure air pressure for 10 minutes. A zero (0) psig loss in air pressure over 10 minutes is considered a leak free system.
- 6.1.5 If leak(s) are present in plumbing connections (loose hose clamps for example), repair as needed.
- 6.1.6 If leak(s) are present but cannot be found, contact IEA representative using the contact information below.
- 6.1.7 Relieve air from system and commence filling procedure.

6.2 System Filling

- 6.2.1 **NEVER FILL SYSTEM WITH UN-INHIBITED WATER! USE INHIBITED COOLANTS ONLY!**
(Refer to **Table 1**).
- 6.2.2 Refer to engine manufacturer instructions for specific filling procedures.
- 6.2.3 Ensure all valves in system are set correctly (open or closed) for proper flow progression
- 6.2.4 Fill system with pump off.
- 6.2.5 Fill through the filler neck located on the top tank (Refer to **Figures 2 and 4**), or pump coolant in through drain port, until the unit is full.
- 6.2.6 Open all vents in radiator top tanks until coolant comes out; then close (Refer to **Figure 2**).
- 6.2.7 **WARNING: DO NOT EXCEED 25 psig in next step!**
- 6.2.8 Turn on pump & circulate coolant until system is deaired (verified via site-glass) and the coolant level stops dropping.
- 6.2.9 Refill system as necessary.
- 6.2.10 Refer to **Figure 4** for plumbing diagram.

6.3 System Venting

- 6.3.1 Ensure all valves in system are set correctly (open or closed) for proper flow progression.
- 6.3.2 Ensure that all vent lines are directed "upward" and contain no loops or dips.
- 6.3.3 All vent lines should terminate in top tanks.
- 6.3.4 **CAUTION: WHEN VENTING COOLANT SYSTEM – HIGH PRESSURE AND HIGH TEMPERATURE COOLANT CAN CAUSE SERIOUS INJURY!**



6.4 Final Unit Inspection

- 6.4.1 Read and understand this manual before operating radiator.
- 6.4.2 Wear approved safety attire when operating the engine (Refer to **Section 1.4**).
- 6.4.3 Visually inspect radiator assembly. Check all decals, hose connections and other hardware.
- 6.4.4 If any parts are broken or missing, repair or replace them before operating the radiator.
- 6.4.5 Ensure all coolant and charge air connections are installed and secure (Refer to **Section 5.3**).
- 6.4.6 Ensure floor mounted air baffles and fork pocket covers are installed and secure. (Refer to **Section 5.1**)
- 6.4.7 Ensure all valves in system are set correctly (open or closed) for proper flow progression.
- 6.4.8 Ensure that qualified personnel have performed all recommended maintenance before operation.
- 6.4.9 Ensure all required air/coolant pressure gauges are present and functioning.

6.5 Initial Run

- 6.5.1 Activate engine and allow it to come up to standard operating temperature under no load (idle).
- 6.5.2 Check coolant connections and fittings for any leaks. Repair as necessary with engine turned off.
- 6.5.3  **Note: Gaskets shrink with time. When refilled, there may be tank to header leaks. Allow 48 hours for gaskets to swell before tightening any bolts. If the bolts are tightened prematurely the gaskets will be ruined and the radiator will require disassembly to replace the gaskets.**
- 6.5.4 If system is leak free at engine standard operating temperature, commence load banking as per manufacturer/site requirements.

7. Appendix I Reference Tables

Ambient Limitations			
	Low	High	Units
Medium	50%/50% Vol Ethylene Glycol/Water		
Operational	-20	110	°F
Storage	-20	150	°F

Jacket Water Circuit			
	Min	Max	Units
Medium	50%/50% Vol Ethylene Glycol/Water		
Inlet Temp	-20	220	°F
Inlet Pressure	NA	20	PSI(g)

ATAAC Circuit			
	Min	Max	Units
Medium	Turbo charged air		
Inlet Temp	NA	500	°F
Inlet Pressure	NA	50	PSI(g)

Table 1: Engine Mounted Radiator limitations

Bolt size	Torque (ft-lbs)	Bolt size	Torque (ft-lbs)
5/16 - 18 (Grade 8)	25	M8 Class 10.9	25
3/8 -16 (Grade 8)	45	M10 Class 10.9	45
1/2-13 (Grade 8)	110	M12 Class 10.9	110
5/8-11 (Grade 8)	185	M14 Class 10.9	185
3/4-10 (Grade 8)	300	M16 Class 10.9	300
7/8-9 (Grade 8)	530	M18 Class 10.9	530

Table 2: Bolt Torque Values

Bushing Type	Bolt Type	TORQUE	
		IN. LBS.	FT. LBS.
H	1/4-20 X 5/8	95	8
SH, SDS	1/4-20 X 1 3/8	108	9
SD	1/4-20 X 7/8	108	9
P1, P2, P3	5/16-18 X 1	192	16
SK	5/16-18 X 2	180	15
Q1, Q2, Q3	3/8-16 X 1 1/4	348	29
R1, R2	3/8-16 X 1 3/4	348	29
SF	3/8-16 X 2	360	30
S1, S2	1/2-13 X 2 1/4	840	70
E	1/2-13 X 2 3/4	720	60
F	9/16-12 X 3 5/8	920	75

Table 3: Bushing Torque Values



8. Appendix II Maintenance Requirements

 **NOTE:** The below table of maintenance check-points are based on standard installation applications. Further maintenance may be required for site-specific installations where standard arrangements cannot be achieved. Always consult IEA during installation for these cases, **prior to coolant line filling and start up**. Extreme working conditions (high ambient or dirty environments) will require more frequent maintenance and inspection.



WARNING: NEVER PERFORM ANY MAINTENANCE PROCEDURES DURING ENGINE OPERATION!

Item	Frequency			
	Daily	Weekly	Monthly	Annual
Lubricate fan bearings with specified grease.	Per lubrication frequency table below			
Check ATAAC condensation drains for moisture.	As required			
Inspect all cores for damage and cleanliness.		√		
Check sight gauges for coolant level and gauge cleanliness.		√		
Listen for unusual sounds from fan and fan drive		√		
Visually inspect all coolant connections for leaks.		√		
Vent air from system if automatic vents are not used.			√	
Check JW and ATAAC hose clamp torques.			√	
Straighten any fins that have become bent or have been flattened.			√	
Clean the cores from the AIR DISCHARGE side of the radiator to avoid pushing the debris further into the core. Use mild detergent that does not react w/ aluminum or copper.				√
Check tank to header bolt torque (25 ft-lbs).				√
Test coolant for proper glycol mixture and ensure it is free from contaminants, corrosion or sediment.				√
Check fan speed with tachometer.				√
All bolted joints are tightened to torques per Table 2.				√

Table 4: Maintenance Schedule

Lubrication Information

- Radiators require greasing at an interval dependent upon usage.
- Table below is lubrication schedule according to service hours.
- All bearings should be greased with Certified Labs Premalube red aluminum complex grease or equivalent. **DO NOT MIX GREASE TYPES.**
- Radiators requiring different lubricants or lubrication methods will be specified on the radiator drawings.
- When lubricating pillow block bearings, add greases slowly until it shows slightly at the seals. This indicates proper bearing lubrication.
- The use of excessive pressure when greasing the bearing can damage the bearing seals.

Service Hours	Lubrication Frequency
40 Hours per Year	Every Six Months
18 Hours per Day	Twice a Month
18 Hours per Day (Dirty Environment)	Once Each Week
24 Hours per Day	Once Each Week
24 Hours per Day (Dirty Environment)	Daily

Table 5: Lubrication Frequency

Condensation drains in ATAAC

NOTE: Condensation may build up in ATAAC during periods of engine inactivity or in applications with high relative humidity and low dew point temperature surfaces. As a general rule, if there is condensation on metal surfaces in the area, condensate should be drained. Drain condensate at frequencies determined by site specific requirements.

- Refer to **Figure 7** below for location of condensation drain.
- Remove the 1/2" NPT plug from center of drain.
- Allow all condensate (if any) to drain from the tube.
- Replace 1/2" NPT plug.
- Tighten plug to 25 ft-lbs.
- Repeat above steps for both Condensate Drains.

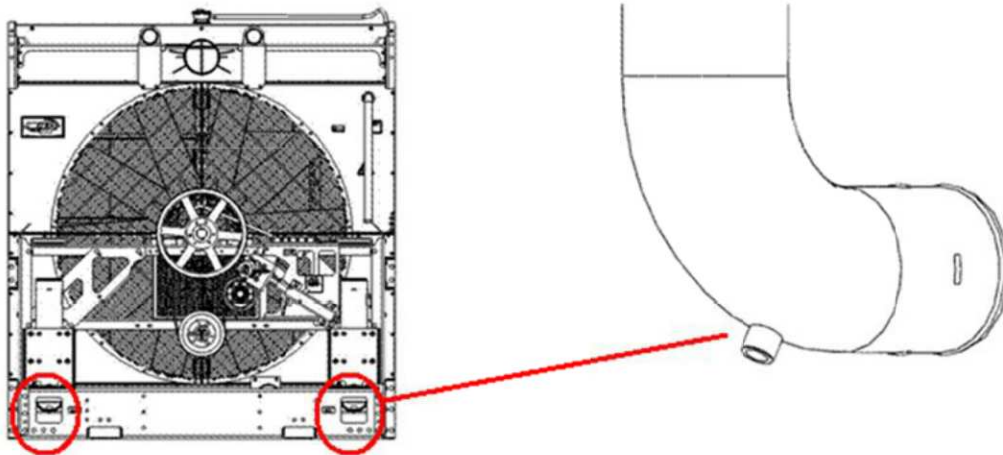

Figure 7: Condensate Drain location

Troubleshooting: Always contact IEA whenever system troubles arise. Before calling the assistance hotline, have the following information prepared (refer to **Figure 8** below):

- Radiator Part Number
- Radiator Serial Number
- Radiator MFG Date
- Number of radiators installed at site.
- Engine Manufacturer and Engine Number.
- Description of site error or failure.

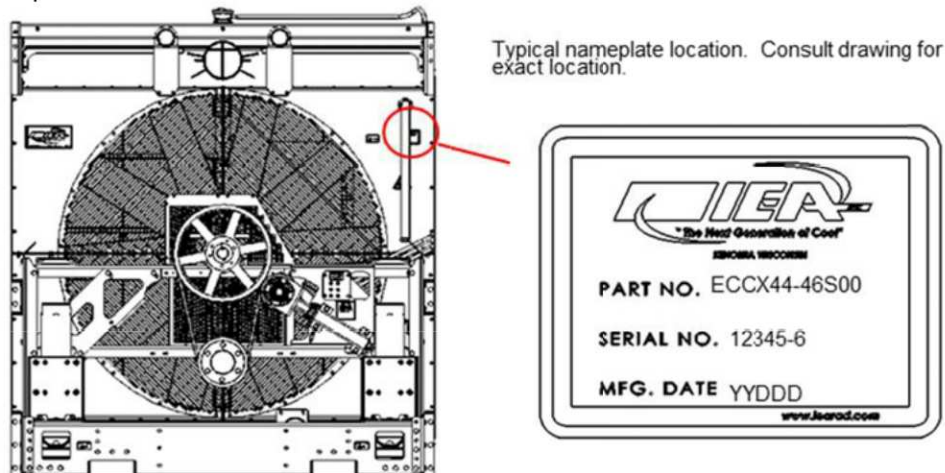

Figure 8: Nameplate location and diagram

9. Appendix III Fan Drive Installation and Belt Tensioning

NOTE: Prior to fan drive installation, ensure all required resources are on hand. Consult IEA packing slip and drawings for detailed list of items shipped with radiator.

Item	Source
Radiator Drawing	IEA supplied
Belt tension specifications	IEA supplied
Belt, sheaves, bushings per packing list	IEA supplied
Socket and wrench set	Customer supplied
3 foot long level	Customer supplied
Belt Tension checking gauge	Customer supplied

Table 6: Fan Drive Installation Resource Table

The chart below is for installation reference.

Step	Action	Result
1	Remove all front and side belt guards.	Gain access to stub.
2	Install radiator per drawing.	Radiator installed so drive system can be aligned.
3	Align drive sheave to driven sheave.	Sheaves aligned so belt can be installed properly.
4	Install belt.	Belt seated into both sheaves.
5	Place tensioner into working position.	Tensioner in correct location.
6	Extend tensioner to tension belts.	Belt properly tensioned
7	Install belt guard.	Drive system properly guarded.

Table 7: Fan Drive Installation Steps

Step 1: Remove all front and side belt guards.

- Remove front and side belt guard components. Refer to **Figure 9** below.
- There is no need to remove back pieces (guard pieces towards radiator).

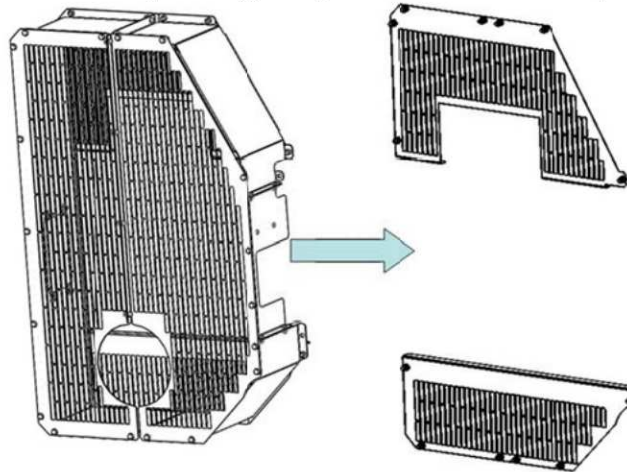

Figure 9: Guard parts to remove

Step 2: Install radiator per drawing

- Install radiator per radiator drawing. Refer to **Figure 10** below. Pay particular attention to the following:
 - a) Spacing between radiator and engine rails.
 - b) Radiator height relative to engine.
 - c) Engine and radiator in line with one another.

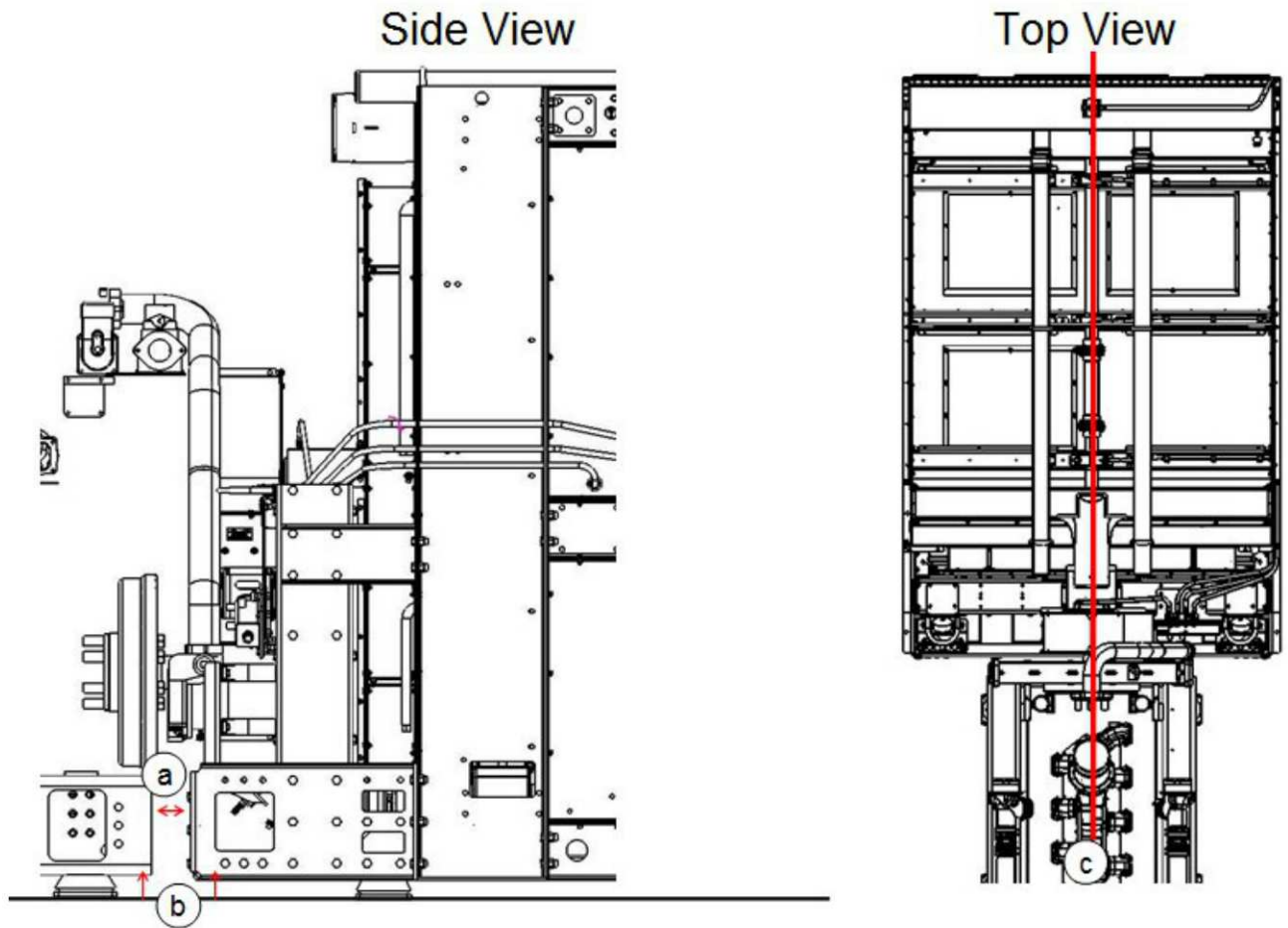

Figure 10: Radiator installation

Step 3: Align drive sheave to driven sheave



NOTE: IEA will deliver radiator with idler sheave aligned to driven sheave.

- Install driven sheave onto stub shaft. Torque taper lock bushing bolts to torque consistent with **Table 3** of this manual.
- Verify alignment with long level. (~3 feet long) Sheaves must be aligned in all three dimensions. Refer to **Figure 11** below.

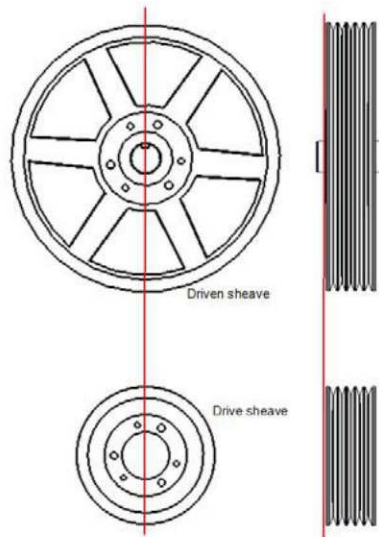

Figure 11: Sheave alignment

Step 4: Install belt

- Slide belt between sheaves and seat belt into grooves.

Step 5: Place tensioner in working location

- If tensioner is received with tensioner in installed position, omit this step. Refer to **Figure 13** below.
- On some units, IEA ships the radiator with the tensioner away from the working location. Loosen bolts holding tensioner in place. Nuts only have to be loose enough to allow movement. Refer to **Figure 12** below.
- Slide tensioner down to end of slot. Tighten nuts to torque specified in **Table 1**.

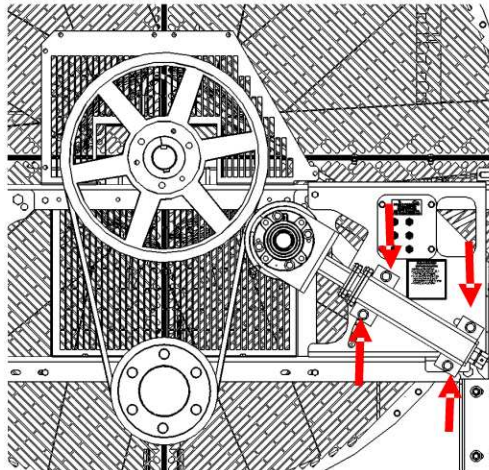

Figure 12: Tensioner in shipping position

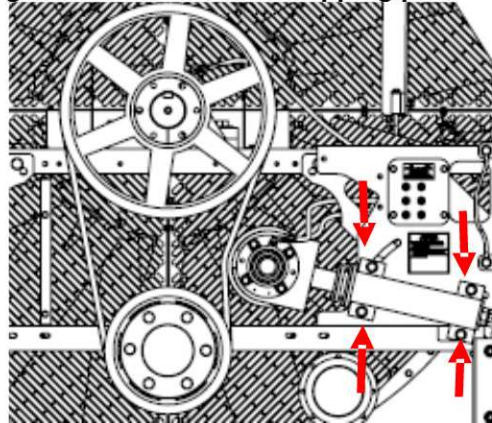

Figure 13: Tensioner in installed position

Step 6: Extend tensioner to tension belt

Refer to **Figure 14** below for nomenclature.

- Loosen jamb nut. Tighten adjusting nut to move idler sheave into belt. Move idler sheave until it makes firm contact with the belt.
- When the idler sheave firmly contacts the belt, measure distance between bearing bracket and middle tube. Refer to **Figure 15** below.
- Tighten belt by tightening adjusting nut. Continue to tighten adjusting nut until measurement between bearing bracket and middle tube is shortened to 3/4".
- Tighten jam nut to outer tube body.

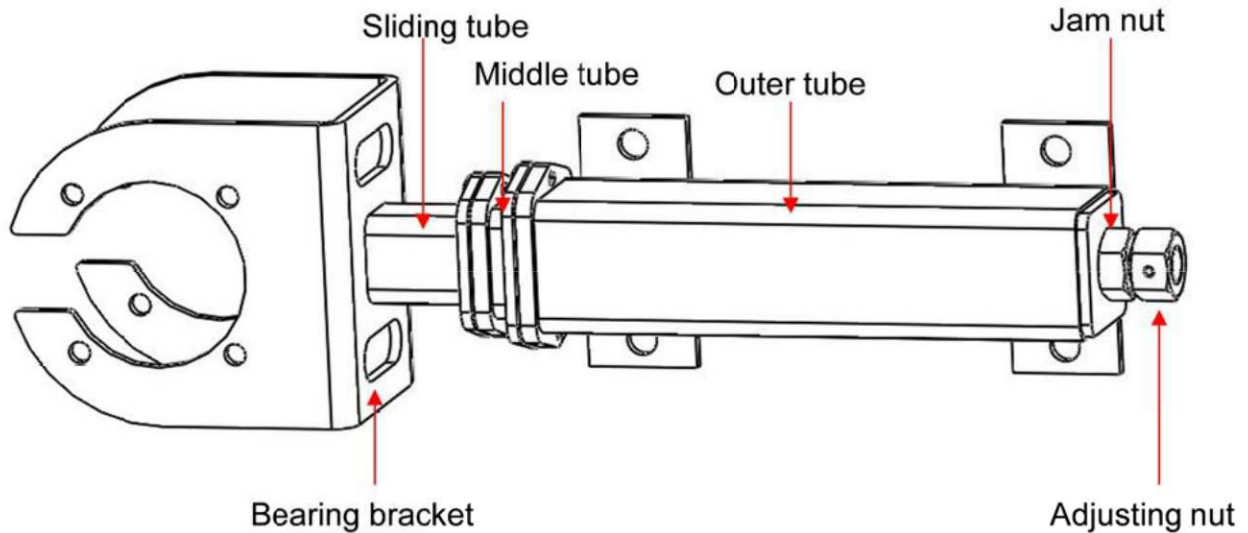

Figure 14: Tensioner nomenclature

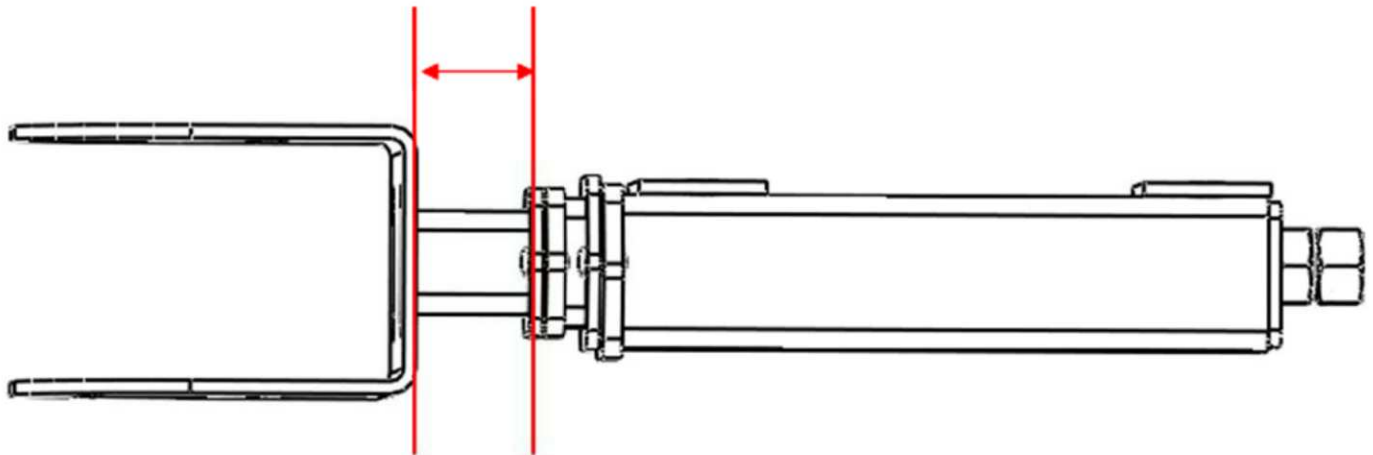

Figure 15: Dimension to take to tension belt

Step 7: Install belt guard

After belt is tensioned properly, place all guards back in place.