

SECTION A-A  
SCALE 1:2  
(B6)

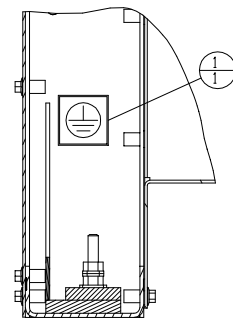

SECTION B-B  
SCALE 1:2  
(B8)

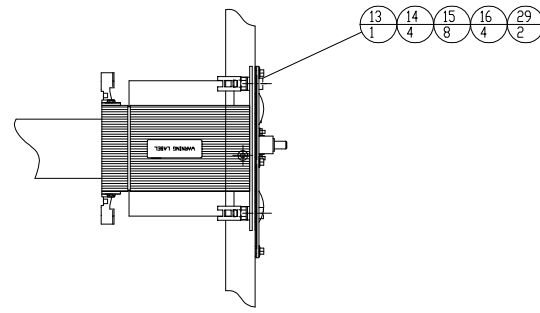

DETAIL C  
SCALE 3:1  
(C4)

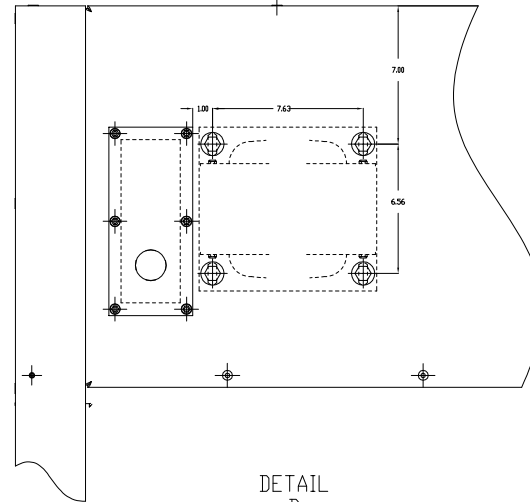

DETAIL D  
SCALE 3:1  
(C2)

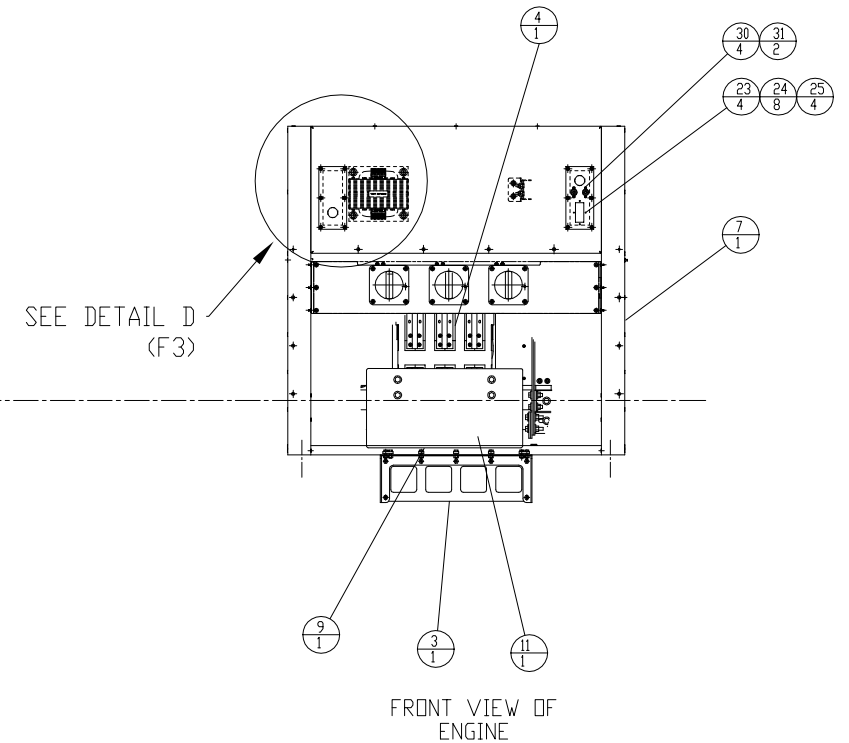
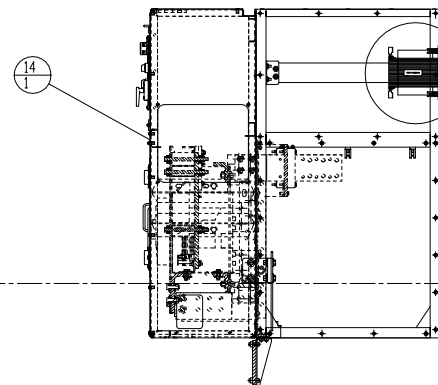
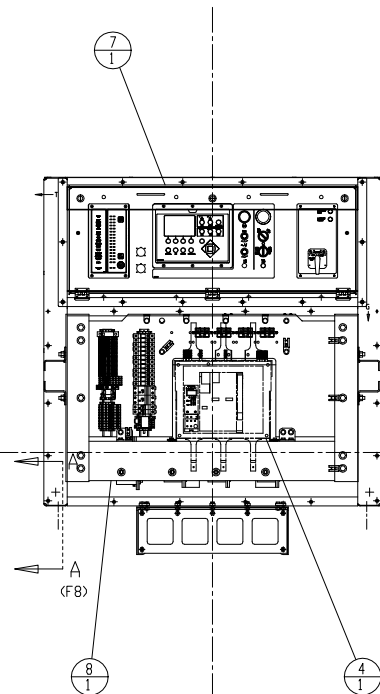
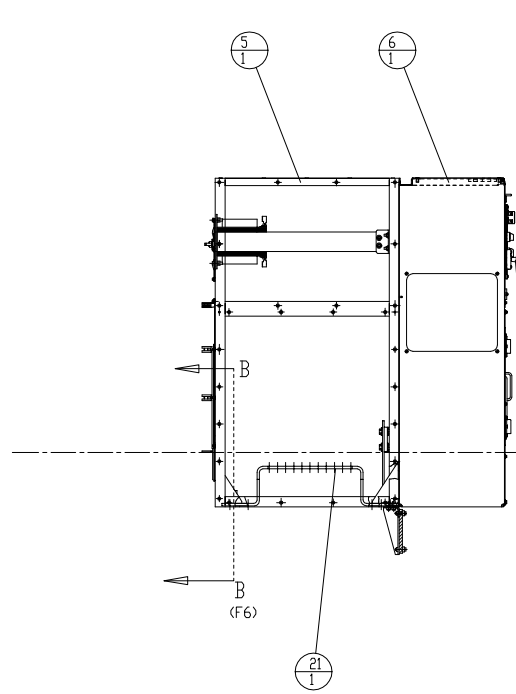
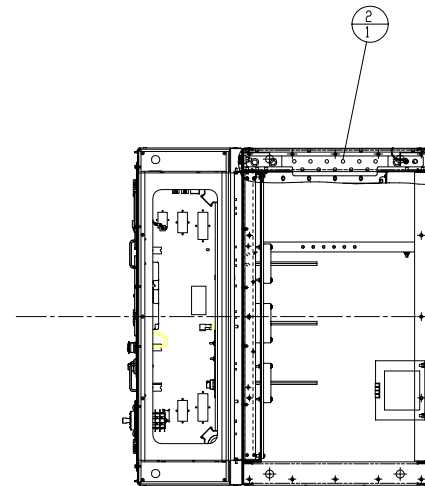

FRONT VIEW OF ENGINE

NO	QTY	MEAS UNIT	PART NO.	NAME
PARTS LIST				
1	1		228-4798	FILM-GROUND
2	1		307-3521	BUS BAR - GROUND
3	1		321-9047	SUPPORT GP-BRACE
4	1		352-7727	BREAKER AS
5	1		356-5634	BOX GP-BASIC
6	1		88E139	BOX GP - EXTENSION
7	1		88E142	BOX GP - CONTROL PANEL
8	1		88E163	MTG GP-BREAKER
9	1		369-3273	GUARD AS
10	2		5C-7261	NUT-HEX M8X1.25
11	1		5P-4116	WASHER-HARD
12	2		8T-4224	WASHER-HARD
A	13		9070T5000D31	TRANSFORMER
D	14	4	8T-4136	BOLT M10x1.5 - 25 Lg
D	15	8	8T-4121	WASHER-HARD
D	16	4	8T-0389	LOCKNUT - M10x1.5
B	17	1	86E133	HARNESS AS. GEN AC TO CDVR
B	18	1	86E150	HARNESS AS. AC SENSING
B	19	1	88E167	HARNESS AS. MAIN DC
B	20	1	88E168	HARNESS AS. MAIN AC
	21	1	88E186	CONNECTION GP - OMEGA BAR
B	22	40	3S-2093	STRAP - CABLE
	23	4	156-6451	SCREW-MACHINE 8-32x1
	24	8	096-6166	WASHER-FLAT
	25	4	6D-5801	LOCKNUT - 8-32
C	26	4	235-4451	BOLT M6x1 - 16 Lg
B	27	1	376-4734	HARNESS AS. - SUPPRESSOR
B	28	1	358-6989	DIODE AS.
	29	2	132-5789	CLIP - LADDER
	30	4	RW4440020SS0000	WASHER - 3/8" SS
	31	2	012-9158	LOCKNUT - 3/8" SS

NOTE A: HAND DRILL MOUNTING HOLES FOR TRANSFORMER  
 NOTE B: NOT SHOWN ON DRAWING FOR CLARITY  
 NOTE C: FOR USE WITH MOUNTING J11 CONNECTOR TO TRANSITION BOX  
 NOTE D: PUNCH MOUNTING HOLES FOR TRANSFORMER USING MOUNTING HOLE TEMPLATE

2/28/14 3 MOVE GENERATOR LEAD IN 2/19/14 2 ADDED BATTERY POS. HW & PIP 2/19/14 1 ADDED OMEGA BAR HARDWARE	DATE BY	<b>ALTORFER</b>	<b>ALTORFER POWER SYSTEMS</b>	
			6315 W. FAUBER RD. PHONE (309) 697-1234 BARTONVILLE, IL 61607 FAX (309) 282-7546	
THIS DOCUMENT CONTAINS PROPRIETARY INFORMATION OF ALTORFER, INC. WITHOUT THE WRITTEN PERMISSION OF ALTORFER, INC., ANY COPYING OR OTHER USE EXCEPT THAT FOR WHICH IT WAS INTENDED IS PROHIBITED.			FILE	PROJECT REFERENCE
ALL DIMENSIONS IN INCHES UNLESS OTHERWISE SPECIFIED			DF\88E	APS2000
TOLERANCES: XXX ± 0.100 XXX ± 0.060 XXXX ± 0.005			SCALE/SHEET SIZE	DRAWN BY
THIRD ANGLE PROJECTION			1-15/D	D. RICHARDSON
ANGULAR ± 1'			SHEET	DATE
			1 OF 1	2/19/2013
TITLE			DRAWING NUMBER	
DOGHOUSE GROUP			88E101-03	