

ITEM	QTY.	PART No.	DESCRIPTION
9	8	172-3959	NUT - SPRING
17	8	5P-1076	WASHER - HARD
18	8	5P-2424	BOLT 1/2"-13

**METRIC** 183-1201

ITEM	QTY.	UNIT	PART NO.	NAME
1	2		2W-7868	GASKET
2	2		2W-7873	GASKET
3	2		5L-3773	GASKET
4	2		148-2296	INSULATION AS
5	2		155-4669	INSULATION AS
6	2		160-7016	FITTING
7	2		167-7934	INSULATION
8	2		167-7935	INSULATION
9	8		172-3959	NUT-SPRING
10	1		180-8477	ADAPTER AS
11	1		187-7739	INSULATION AS
12	1		205-2939	MUFFLER GP-BASIC
13	1		205-2840	MUFFLER GP-BASIC
14	24		1A-1460	BOLT 1/2-13
15	40		1C-2251	BOLT 3/8-16
16	24		1F-7958	NUT-FULL 1/2-13
17	8		5P-1076	WASHER-HARD
18	8		5P-2424	BOLT 1/2-13
19	48		5P-8245	WASHER-HARD
20	40		9S-8752	NUT-FULL 3/8-16
21	64		9X-6458	WASHER-HARD

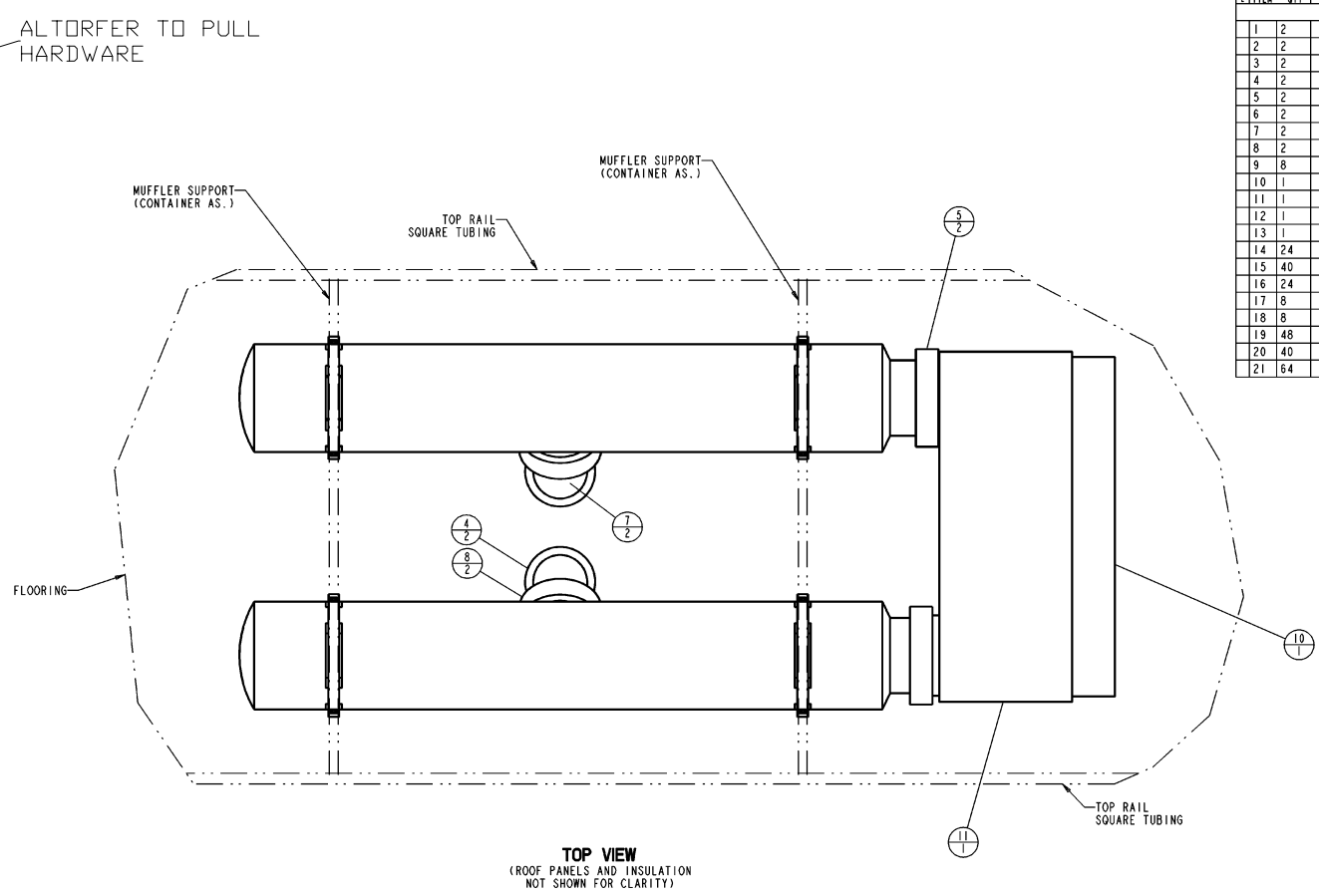
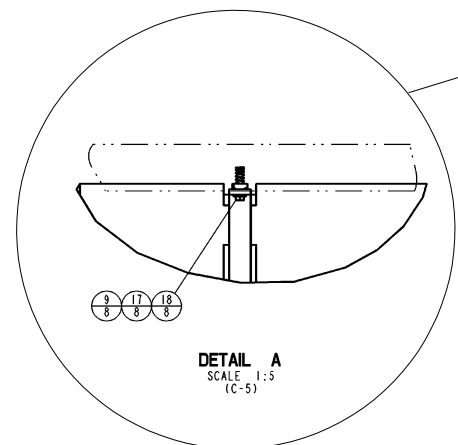

**TOP VIEW**  
(ROOF PANELS AND INSULATION NOT SHOWN FOR CLARITY)

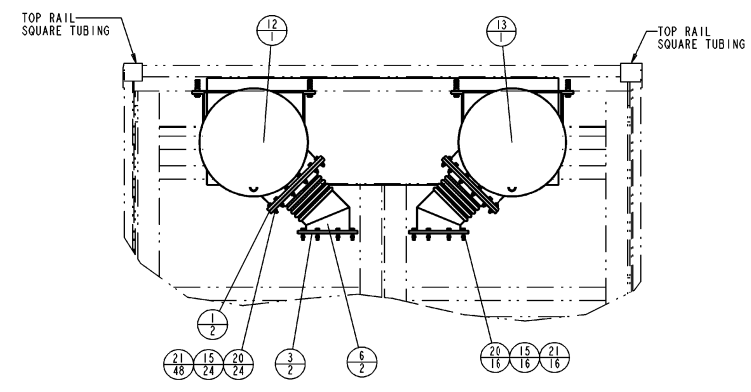

**FRONT VIEW**  
(FRONT WALL AND INSULATION NOT SHOWN FOR CLARITY)

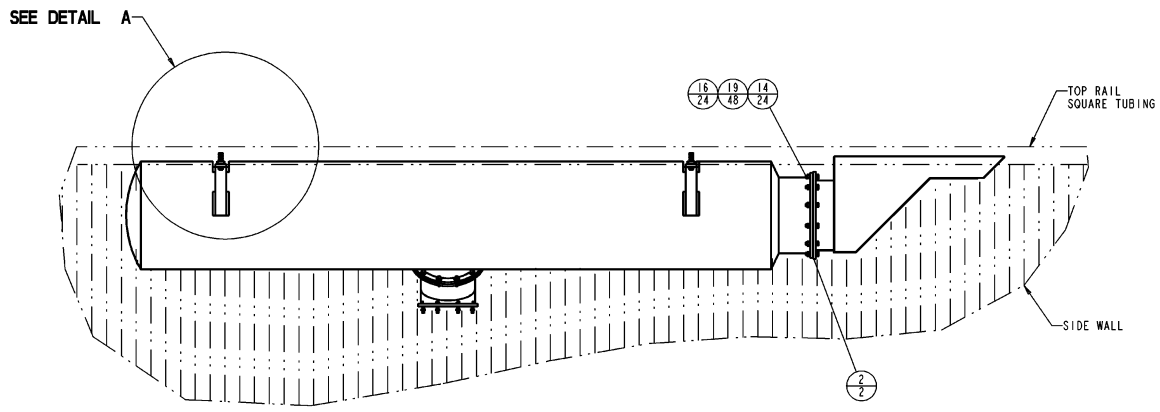

**ROADSIDE VIEW**  
(ROADSIDE WALL AND INSULATION NOT SHOWN FOR CLARITY)

NOTE A: REF. EXHAUST KIT# RUT-16-6451

DATE	06/15/18
BY	BML
REVISION	REVISED HARDWARE
NO.	1
DATE	03/08/18
BY	BML
REVISION	PROT
NO.	0
DATE	03/08/18
BY	BML
REVISION	ENG
NO.	0
DATE	03/08/18
BY	BML
REVISION	PROT
NO.	0
DATE	03/08/18
BY	BML
REVISION	ENG
NO.	0
DATE	03/08/18
BY	BML
REVISION	PROT
NO.	0
DATE	03/08/18
BY	BML
REVISION	ENG
NO.	0
DATE	03/08/18
BY	BML
REVISION	PROT
NO.	0
DATE	03/08/18
BY	BML
REVISION	ENG
NO.	0
DATE	03/08/18
BY	BML
REVISION	PROT
NO.	0
DATE	03/08/18
BY	BML
REVISION	ENG
NO.	0
DATE	03/08/18
BY	BML
REVISION	PROT
NO.	0
DATE	03/08/18
BY	BML
REVISION	ENG
NO.	0
DATE	03/08/18
BY	BML
REVISION	PROT
NO.	0
DATE	03/08/18
BY	BML
REVISION	ENG
NO.	0
DATE	03/08/18
BY	BML
REVISION	PROT
NO.	0
DATE	03/08/18
BY	BML
REVISION	ENG
NO.	0
DATE	03/08/18
BY	BML
REVISION	PROT
NO.	0
DATE	03/08/18
BY	BML
REVISION	ENG
NO.	0
DATE	03/08/18
BY	BML
REVISION	PROT
NO.	0
DATE	03/08/18
BY	BML
REVISION	ENG
NO.	0
DATE	03/08/18
BY	BML
REVISION	PROT
NO.	0
DATE	03/08/18
BY	BML
REVISION	ENG
NO.	0
DATE	03/08/18
BY	BML
REVISION	PROT
NO.	0
DATE	03/08/18
BY	BML
REVISION	ENG
NO.	0
DATE	03/08/18
BY	BML
REVISION	PROT
NO.	0
DATE	03/08/18
BY	BML
REVISION	ENG
NO.	0
DATE	03/08/18
BY	BML
REVISION	PROT
NO.	0
DATE	03/08/18
BY	BML
REVISION	ENG
NO.	0
DATE	03/08/18
BY	BML
REVISION	PROT
NO.	0
DATE	03/08/18
BY	BML
REVISION	ENG
NO.	0
DATE	03/08/18
BY	BML
REVISION	PROT
NO.	0
DATE	03/08/18
BY	BML
REVISION	ENG
NO.	0
DATE	03/08/18
BY	BML
REVISION	PROT
NO.	0
DATE	03/08/18
BY	BML
REVISION	ENG
NO.	0
DATE	03/08/18
BY	BML
REVISION	PROT
NO.	0
DATE	03/08/18
BY	BML
REVISION	ENG
NO.	0
DATE	03/08/18
BY	BML
REVISION	PROT
NO.	0
DATE	03/08/18
BY	BML
REVISION	ENG
NO.	0
DATE	03/08/18
BY	BML
REVISION	PROT
NO.	0
DATE	03/08/18
BY	BML
REVISION	ENG
NO.	0
DATE	03/08/18
BY	BML
REVISION	PROT
NO.	0
DATE	03/08/18
BY	BML
REVISION	ENG
NO.	0
DATE	03/08/18
BY	BML
REVISION	PROT
NO.	0
DATE	03/08/18
BY	BML
REVISION	ENG
NO.	0
DATE	03/08/18
BY	BML
REVISION	PROT
NO.	0
DATE	03/08/18
BY	BML
REVISION	ENG
NO.	0
DATE	03/08/18
BY	BML
REVISION	PROT
NO.	0
DATE	03/08/18
BY	BML
REVISION	ENG
NO.	0
DATE	03/08/18
BY	BML
REVISION	PROT
NO.	0
DATE	03/08/18
BY	BML
REVISION	ENG
NO.	0
DATE	03/08/18
BY	BML
REVISION	PROT
NO.	0
DATE	03/08/18
BY	BML
REVISION	ENG
NO.	0
DATE	03/08/18
BY	BML
REVISION	PROT
NO.	0
DATE	03/08/18
BY	BML
REVISION	ENG
NO.	0
DATE	03/08/18
BY	BML
REVISION	PROT
NO.	0
DATE	03/08/18
BY	BML
REVISION	ENG
NO.	0
DATE	03/08/18
BY	BML
REVISION	PROT
NO.	0
DATE	03/08/18
BY	BML
REVISION	ENG
NO.	0
DATE	03/08/18
BY	BML
REVISION	PROT
NO.	0
DATE	03/08/18
BY	BML
REVISION	ENG
NO.	0
DATE	03/08/18
BY	BML
REVISION	PROT
NO.	0
DATE	03/08/18
BY	BML
REVISION	ENG
NO.	0
DATE	03/08/18
BY	BML
REVISION	PROT
NO.	0
DATE	03/08/18
BY	BML
REVISION	ENG
NO.	0
DATE	03/08/18
BY	BML
REVISION	PROT
NO.	0
DATE	03/08/18
BY	BML
REVISION	ENG
NO.	0
DATE	03/08/18
BY	BML
REVISION	PROT
NO.	0
DATE	03/08/18
BY	BML
REVISION	ENG
NO.	0
DATE	03/08/18
BY	BML
REVISION	PROT
NO.	0
DATE	03/08/18
BY	BML
REVISION	ENG
NO.	0
DATE	03/08/18
BY	BML
REVISION	PROT
NO.	0
DATE	03/08/18
BY	BML
REVISION	ENG
NO.	0
DATE	03/08/18
BY	BML
REVISION	PROT
NO.	0
DATE	03/08/18
BY	BML
REVISION	ENG
NO.	0
DATE	03/08/18
BY	BML
REVISION	PROT
NO.	0
DATE	03/08/18
BY	BML
REVISION	ENG
NO.	0
DATE	03/08/18
BY	BML
REVISION	PROT
NO.	0
DATE	03/08/18
BY	BML
REVISION	ENG
NO.	0
DATE	03/08/18
BY	BML
REVISION	PROT
NO.	0
DATE	03/08/18
BY	BML
REVISION	ENG
NO.	0
DATE	03/08/18
BY	BML
REVISION	PROT
NO.	0
DATE	03/08/18
BY	BML
REVISION	ENG
NO.	0
DATE	03/08/18
BY	BML
REVISION	PROT
NO.	0
DATE	03/08/18
BY	BML
REVISION	ENG
NO.	0
DATE	03/08/18
BY	BML
REVISION	PROT
NO.	0
DATE	03/08/18
BY	BML
REVISION	ENG
NO.	0
DATE	03/08/18
BY	BML
REVISION	PROT
NO.	0
DATE	03/08/18
BY	BML
REVISION	ENG
NO.	0
DATE	03/08/18
BY	BML
REVISION	PROT
NO.	0
DATE	03/08/18
BY	BML
REVISION	ENG
NO.	0
DATE	03/08/18
BY	BML
REVISION	PROT
NO.	0
DATE	03/08/18
BY	BML
REVISION	ENG
NO.	0
DATE	03/08/18
BY	BML
REVISION	PROT
NO.	0
DATE	03/08/18
BY	BML
REVISION	ENG
NO.	0
DATE	03/08/18
BY	BML
REVISION	PROT
NO.	0
DATE	03/08/18
BY	BML
REVISION	ENG
NO.	0
DATE	03/08/18
BY	BML
REVISION	PROT
NO.	0
DATE	03/08/18
BY	BML
REVISION	ENG
NO.	0
DATE	03/08/18
BY	BML
REVISION	PROT
NO.	0
DATE	03/08/18
BY	BML
REVISION	ENG
NO.	0
DATE	03/08/18
BY	BML
REVISION	PROT
NO.	0
DATE	03/08/18
BY	BML
REVISION	ENG
NO.	0
DATE	03/08/18
BY	BML
REVISION	PROT
NO.	0
DATE	03/08/18
BY	BML
REVISION	ENG
NO.	0
DATE	03/08/18
BY	BML
REVISION	PROT
NO.	0
DATE	03/08/18
BY	BML
REVISION	ENG
NO.	0
DATE	03/08/18
BY	BML
REVISION	PROT
NO.	0
DATE	03/08/18
BY	BML
REVISION	ENG
NO.	0
DATE	03/08/18
BY	BML
REVISION	PROT
NO.	0