

TOP VIEW (ROOF REMOVED)

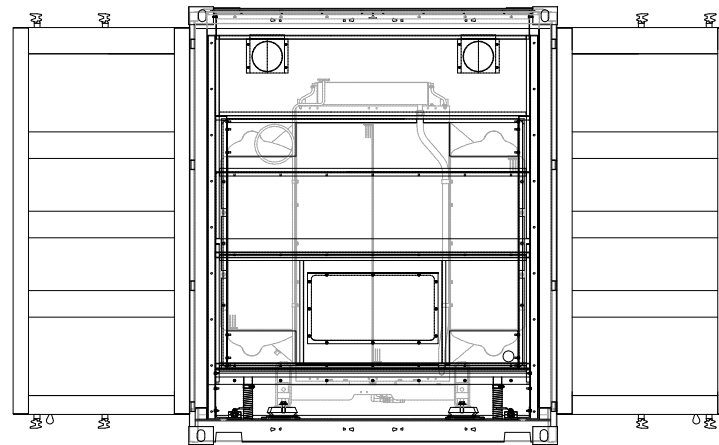

REAR VIEW (DOORS OPEN)

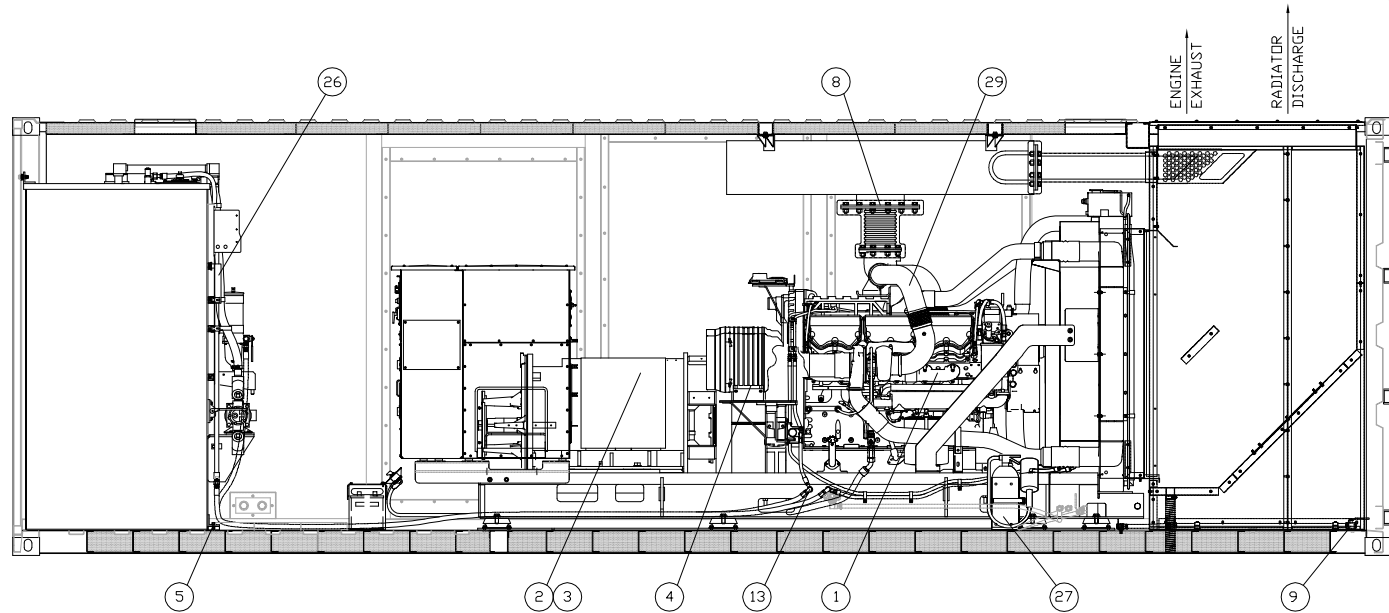

STREET SIDE VIEW (WALL REMOVED)

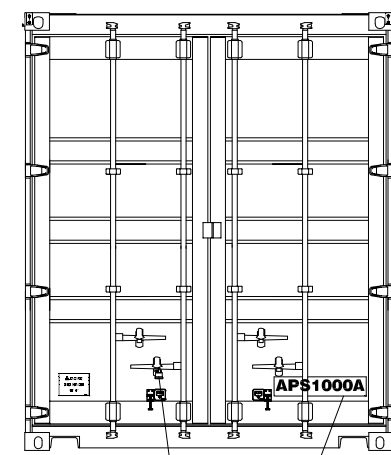

REAR VIEW (DOORS CLOSED)

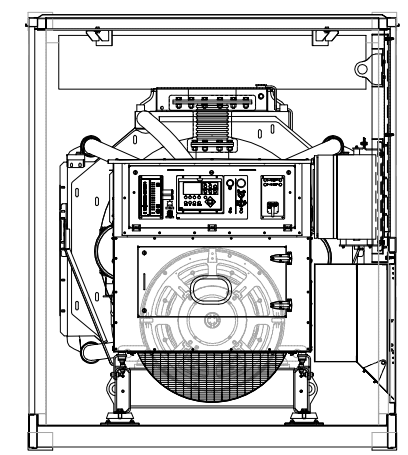

CONTROLS VIEW

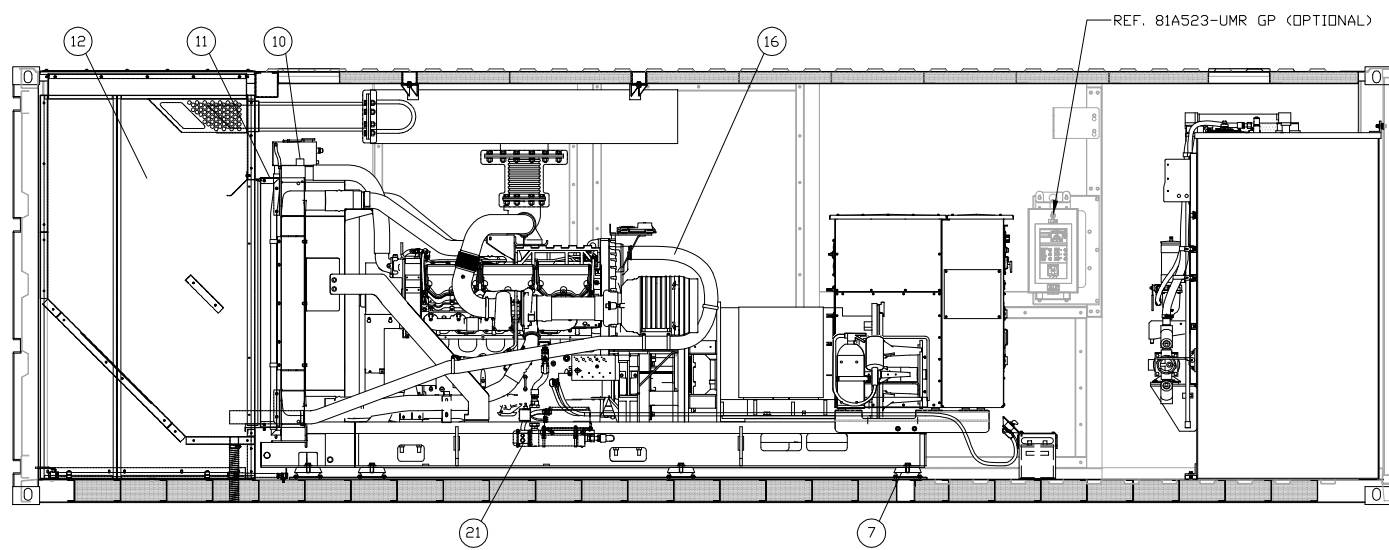

CURB SIDE VIEW (WALL REMOVED)

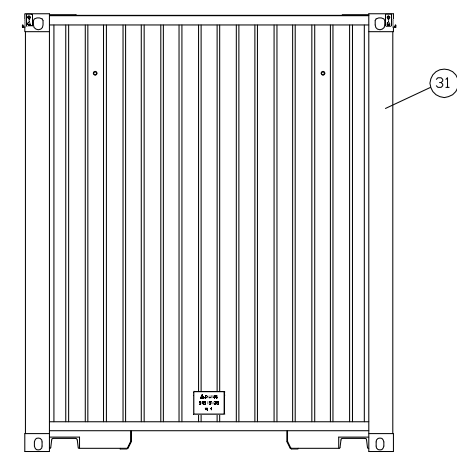

FRONT VIEW

ITEM	QTY.	GROUP NO.	DESCRIPTION
1	1	466-3231	CATERPILLAR C32 ENGINE AR-EPG
2	1	285-6738	SR4B GENERATOR AR-POWER (480V)
3	1	271-8138	ADAPTER GROUP - GENERATOR COUPLING
4	1	435-0400	AIR CLEANER GROUP
5	1	81A502	FUEL TANK MOUNTING GROUP
6	1	81A503	CONDUIT & JUNCTION BOX INSTALLATION GROUP
7	1	81A504	GENSET MOUNTING GROUP
8	1	81A505	EXHAUST SILENCER MOUNTING GROUP
9	1	81A506	SPILL CONTAINMENT DRAINS GROUP
10	1	81A507	RADIATOR MOUNTING GROUP
11	1	81A508	RADIATOR DUCT GROUP
12	1	81A509	DISCHARGE DIVERTER INSTALLATION GROUP
13	1	81A510	FUEL LINES MOUNTING GROUP
14	1	81A511	ENGINE OIL & COOLANT REMOTE DRAINS GROUP
15	1	81A512	CAC & JWH LINES INSTALLATION GROUP
16	1	81A513	OCV (OPEN CRANKCASE VENT) MOUNTING GROUP
17	1	81A514	STARTING BATTERIES INSTALLATION GROUP
18	1	81A540	"QUICKFIT KIT" (RPM INDUSTRIES) OIL DRAIN & FILL KIT
19	1	81A516	CONTAINER ACCESS MOUNTING GROUP
20	1	81A517	PLATFORM MOUNTING GROUP
21	1	81A518	JACKET WATER HEATER GROUP
22	1	81A519	CONTAINER FILMS GROUP
23	1	81A520	LOAD PAN GROUP
24	1	81A521	TRANSITION BOX INSTALLATION GROUP
25	1	81A524	INSTALLATION AR - CONTROLS (DOGHOUSE)
26	1	81A525	DOCUMENT BOX GROUP
27	1	81A526	FIRE EXTINGUISHER GROUP
28	1	81A529	APS1000 LOCK GROUP
29	1	81A530	ENGINE EXHAUST (TURBO PIPING) BLANKET GROUP
30	1	81A532	CAC (RETURN AIR PIPING) BLANKET GROUP
31	1	81A533	PARALLELING HARNESS GROUP
32	1	81A534	CONTAINER GROUP

NOTE A: ILLUSTRATIONS SHOWN ON THIS SHEET ARE FOR INFORMATION PURPOSES ONLY AND MAY NOT REFLECT ACTUAL CONSTRUCTION. DO NOT SCALE FROM THIS DRAWING. PLEASE REFERENCE TOP LEVEL GROUP DRAWINGS DENOTED ABOVE AND THE GENERAL DIMENSIONS DRAWING 81A600 FOR MORE INFORMATION. ALSO SEE MANUFACTURER LITERATURE PROVIDED IN DOCUMENT BOX.

NOTE B: 81A515-ENGINE COMPARTMENT FILMS SHALL BE RECEIVED IN 81A519BM-00 AND/ OR 81A519BM-CSA. USE 81A515 DRAWING AS A REFERENCE FOR THE INSTALLATION OF ENGINE ROOM FILMS.

DATE			ALTORFER POWER SYSTEMS 6315 W. FAUBER RD. PHONE (309) 697-1234 BARTONVILLE, IL 61607 FAX (309) 262-7546	
	THIS DOCUMENT CONTAINS PROPRIETARY INFORMATION OF ALTORFER, INC. WITHOUT THE WRITTEN PERMISSION OF ALTORFER, INC., ANY COPYING OR OTHER USE EXCEPT THAT FOR WHICH IT WAS INTENDED IS PROHIBITED.			
CHANGE NOTICE	ALL DIMENSIONS IN INCHES UNLESS OTHERWISE SPECIFIED	FILE	PROJECT REFERENCE	
	TOLERANCES: XX ± 0.100 THIRD ANGLE PROJECTION XX ± 0.060 XX ± 0.005 ANGULAR ± 1°	DF/81A	SCALE/SHEET SIZE	DRAWN BY
		1=25/D	JAM	QUOTE NUMBER
		SHEET	DATE	WORK ORDER NUMBER
		1 OF 1	01-08-15	-
				DRAWING NUMBER
				81A500-00