

ITEM	QTY	MEAS UNIT	PART NO.	NAME
MISC REF				
1				
2				
3				
4				
5				
6	2		7C-6121	MOUNT
7	2		5N-9067	COLLAR
8	1		9Y-9771	FILM
9	3		4P-2160	WASHER
10	3		4P-2161	SCREW
11	3		4P-2162	CLIP
12	1		104-7287	PANEL AS.
13	2		5N-9072	CLIP
14	16	dm	5N-8359	CONDUIT
15	2		5N-9117	ADAPTER
16	2		062-5388	LOCKNUT
17	1		204-9551	PANEL AS.
18	1		204-0747	BOX AS.

NOTE: REFERENCE CAT DRAWING# 194-7764-03 SHEET 2 FOR BILL OF MATERIALS.

- NOTE A: MOUNT FILMS ON CONTROL PANEL FLOOR.
- NOTE B: FRONT PANEL TO BE 14 GA HINGED AT BOTTOM. BOLT OR PIN SECURE AT THE TOP.
- NOTE C: COMPLETE CONTROL PANEL SHALL BE FINISH PAINTED CATERPILLAR YELLOW, INSTRUMENT DOOR SHALL BE PAINTED FLAT BLACK.
- NOTE D: CONTROL PANEL BOX TO BE 14 GA. FORMED CONSTRUCTION.
- NOTE E: IDENTIFICATION NAME PLATE SHALL BE PERMANENTLY AFFIXED TO THE INSIDE LOWER SURFACE OF THE CONTROL PANEL ENCLOSURE & SHALL INCLUDE THE PANEL PART NUMBER, MODEL NUMBER & DATE CODE OF MANUFACTURE.
- NOTE F: A COMPLETE SET OF CATERPILLAR DRAWINGS SHALL BE PACKED INSIDE EACH CONTROL PANEL.
- NOTE G: CONTROL PANEL ENCLOSURE JOINTS & HARDWARE MOUNTING HOLES SHALL BE SEALED WITH DOW CORNING RTV732.

ALTORFER		ALTORFER POWER SYSTEMS	
6315 W. FAUBER RD. BARTONVILLE, IL 61607		PHONE (309) 697-1234 FAX (309) 282-7546	
THIS DOCUMENT CONTAINS PROPRIETARY INFORMATION OF ALTORFER, INC. WITHOUT THE WRITTEN PERMISSION OF ALTORFER, INC. ANY COPYING OR OTHER USE EXCEPT THAT FOR WHICH IT WAS INTENDED IS PROHIBITED.			
ADD REV. DATE & REVISIONS IN RED INCHES & TERMINALS IN BLACK CHANGE NOTICE 1 ME	ALL DIMENSIONS IN INCHES (UNLESS OTHERWISE SPECIFIED)	FILE	PROJECT REFERENCE
	TOLERANCES: X.X ± 0.100 X.XX ± 0.050 X.XXX ± 0.005	THIRD ANGLE PROJECTION	DF/54E
	SCALE/SHEET SIZE	DRAWN BY	QUOTE NUMBER
	ANGULAR ± 1'	SHEET	D. ROLING
TITLE		DATE	WORK ORDER NUMBER
XQ400RM (3456) CONTROL PANEL GROUP		12/01/2015	DRAWING NUMBER
		2 OF 3	54A415-01

LEFT SIDE OF ENCLOSURE

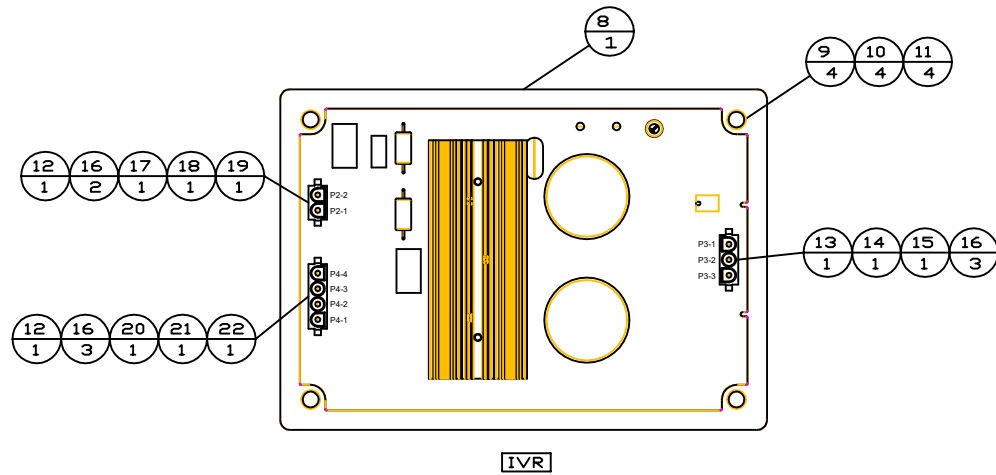
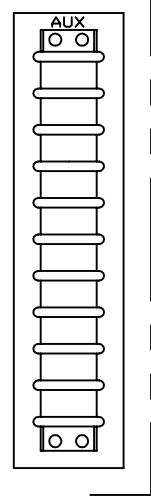

TS1

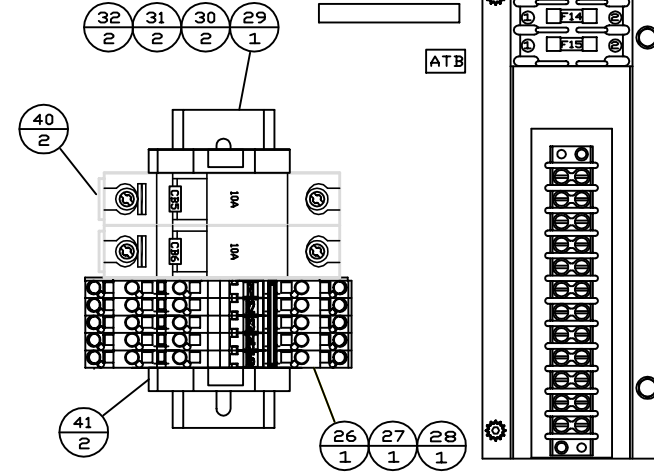
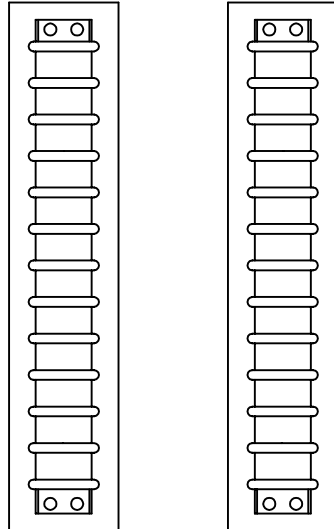

ATB

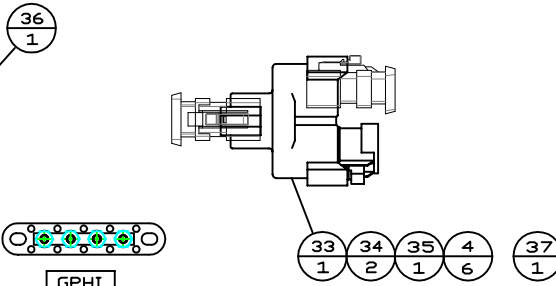
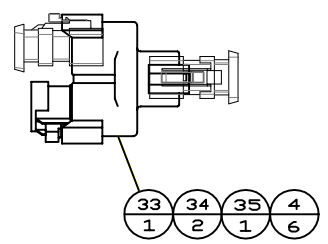
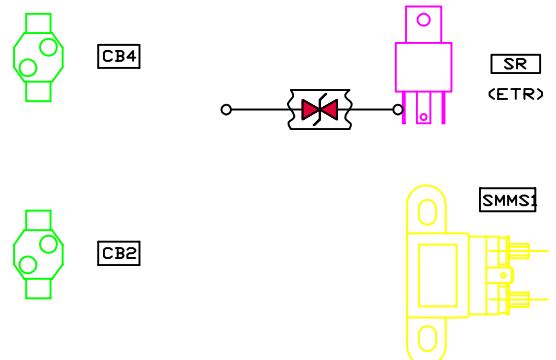

SUB PAN (FRONT VIEW)

INSTRUMENT DOOR (TOP VIEW WITH DOOR OPEN)

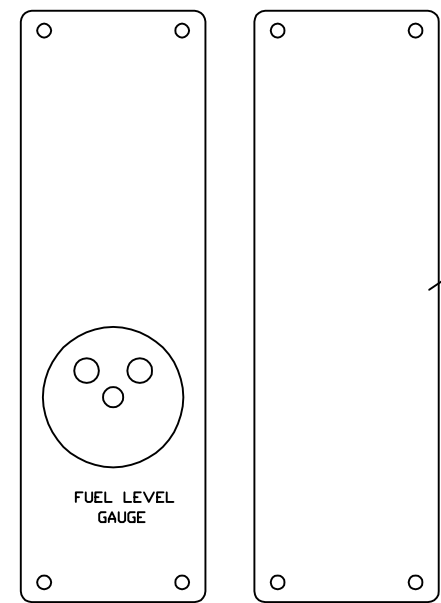
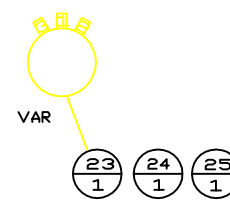
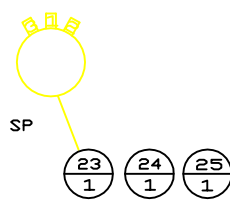
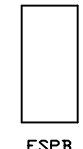
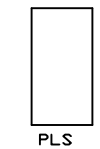
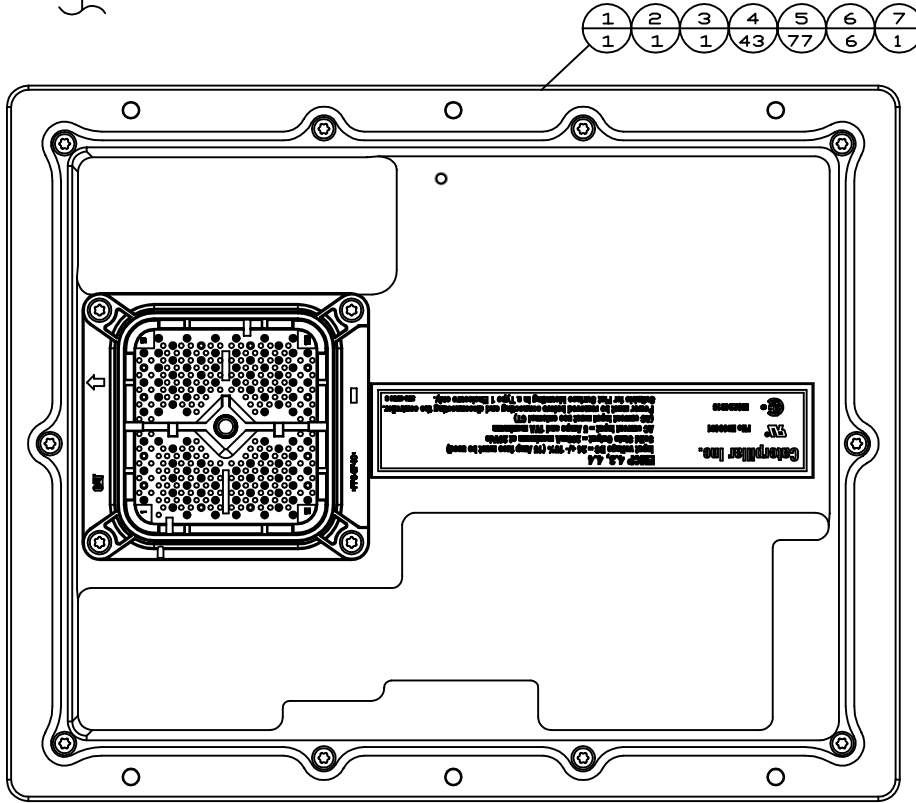

ITEM	QTY.	PART NUMBER	DESCRIPTION
1	1	450-9609	EMCP4.3 CONTROL GROUP
2	1	103-6272	SEAL
3	1	264-5732	PLUG-120 PIN
4	55	126-1768	SOCKET-CONNECTOR (GOLD)
5	77	8T-8737	PLUG-SEALING
6	6	243-5027	NUT-M6X1
7	1	233-7742	SCREW-EMCP GND.
8	1	398-7248	IVR CONTROL ASSEMBLY
9	4	9X-8256	WASHER-HARD 1/4"
10	4	7X-2501	BOLT 1/4" X 1-1/4"
11	4	150-4286	NUTSERT 1/4"-20
12	2	416-4615	CORE SUPPRESSION FERRITE BEADS
13	1	366-9370	P3 PLUG HOUSING
14	1	416-1335	P3 INTERFACE SEAL
15	1	416-1334	P3 WIRE SEAL
16	8	244-0452	CONTACT- MATE-N-LCK
17	1	416-1367	P2 PLUG HOUSING
18	1	416-1332	P2 INTERFACE SEAL
19	1	416-1333	P2 WIRE SEAL
20	1	351-9187	P4 PLUG HOUSING
21	1	416-1336	P4 INTERFACE SEAL
22	1	416-1337	P4 WIRE SEAL
23	2	4W-5972	KNOB
24	2	7C-4550	SEAL-ROD. SFT.
25	2	MW22B-10-1K	POTENTIOMETER-10 TURN 1K
26	5	347-0328	BLOCK-RELAY
27	1	347-0329	COVER-END
28	1	347-0337	BAR-FIXED BRIDGE
29	12cm	147-1960	RAIL-DIN
30	2	6V-7978	SCREW-10-32 X 3/4"
31	2	33074	WASHER-FLAT #10
32	2	6V-5157	INSERT-THREADED 10-32
33	2	133-0970	RECEPTACLE
34	4	174-0503	PLUG KIT
35	2	174-3016	PLUG ASSY.-RESISTOR
36	1	9W-1951	RECEPTACLE ASSY.-SVC CONN.
37	31dm	153-2707	SHIELDED WIRE-J1939
38	1	139-2118	SWITCH ASSY.-TOGGLE (VFSS)
39	1	54C300	PLATE-ANNUNCIATOR BLOCKOFF
40	2	125-9962	BREAKER-10 AMP
41	2	314-9101	BRACKET-END
42	1	102-8802	RECEPTACLE ASSY. 2 PIN
43	1	102-8804	RECEPTACLE ASSY. 4 PIN
44	1	155-2274	PLUG ASSY. 6 PIN
45	12	126-1767	SOCKET-CONNECTOR (GOLD)
46	1	155-2270	PLUG ASSY. 2 PIN
47	1	155-2271	PLUG ASSY. 4 PIN
48	1	126-1767	PIN-CONNECTOR (GOLD)

NOTE: VFSS LOCATED ON LOAD PAN BY CHANGEDOVER BOARD

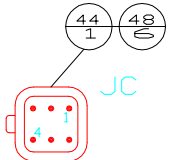
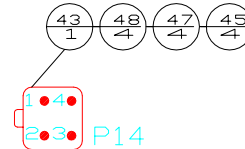
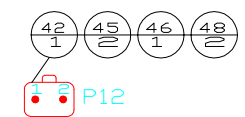

		ALTORFER POWER SYSTEMS 8315 W. FAUBER RD. PHONE (309) 897-1234 BARTONVILLE, IL 61807 FAX (309) 282-7546	
THIS DOCUMENT CONTAINS PROPRIETARY INFORMATION OF ALTORFER, INC. WITHOUT THE WRITTEN PERMISSION OF ALTORFER, INC. ANY COPYING OR OTHER USE EXCEPT THAT FOR WHICH IT WAS INTENDED IS PROHIBITED.	ALL DIMENSIONS IN INCHES UNLESS OTHERWISE SPECIFIED	FILE: DF/54E	PROJECT REFERENCE: XQ400 (3456) RENTAL UNIT
TOLERANCES: XX ± 0.100 XXX ± 0.050 XXXX ± 0.005	THIRD ANGLE PROJECTION	SCALE/SHEET SIZE: 1=1/D	DRAWN BY: D. ROLLING
ANGULAR ± 1°	SHEET: 3 OF 3	DATE: 12/08/2015	WORK ORDER NUMBER:
TITLE: XQ400RM (3456) CONTROL PANEL LAYOUT			DRAWING NUMBER: 54A415-01