

ITEM	QTY.	DESCRIPTION	WEIGHT
1	1	54C263 - SILENCER ASSEMBLY	280
2	1	54C260-1 - FLEX ASSEMBLY	40
3	1	54C261-2 - PIPE ASSEMBLY	21
4	1	54C264 - ELBDW ASSEMBLY	31
5	1	54C262-1 - BLANKET GROUP	8
6	1	610406 - 6" SEAL CLAMP	--
7	1	57D124 - 8" RAIN CAP	2
8	1	5H8331 - EXHAUST GASKET	--
9	4	7X-0346 - 5/8-11X2.0 BOLT	--
10	8	8T-4122 - 5/8 FLATWASHER	--
11	4	7X-0448 - 5/8-11 NC NUT	--
12	2	GHT8 - 8" ASA EXHAUST GASKET	--
13	16	7X-0366 - 3/4-10x2.0 BOLT	13
14	32	8T-4994 - 3/4 FLATWASHER	--
15	16	6V-8182 - 3/4-10NC NUT	--
16	8	345-8531 - 3/8-16x1.0 FLANGE BOLT	--
17	10	198-2970 - 3/8-16NC FLANGE NUT	--
18	1	*54C255 - EXHAUST HANGER AS.	3
19	1	*54C163 - EXHAUST HANGER	2
TOTAL			400

\* - REFERENCE ONLY

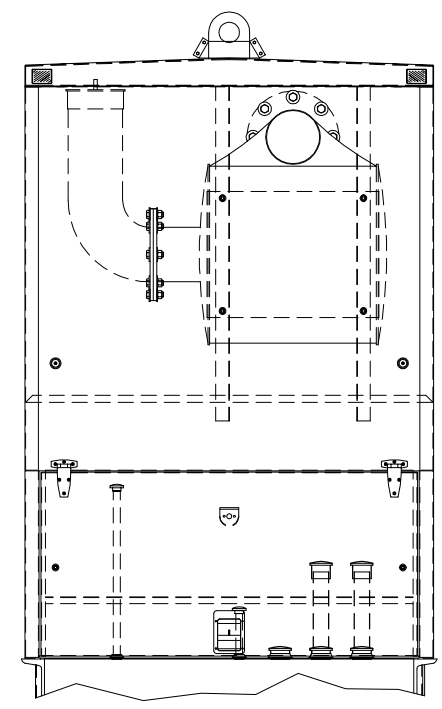
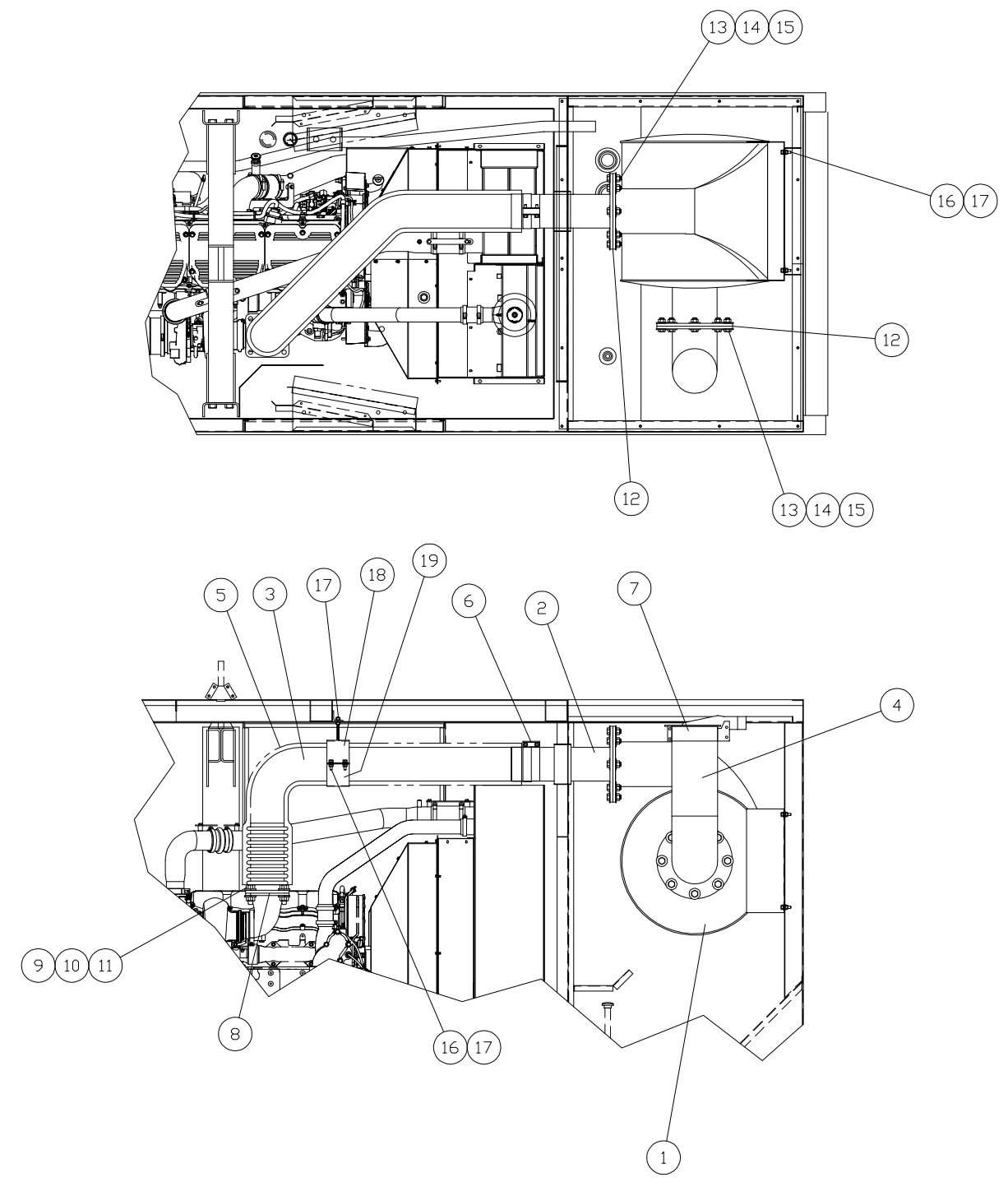

NOTE: ITEMS #18 & 19 RECEIVED WITH ENCLOSURE PARTS GROUP 54C200BM

<p>DATE: 06/27/13 BY: [Signature]</p>		<p><b>ALTORFER</b> 6315 W. FAUBER RD. PHONE (309) 697-1234 BARTONVILLE, IL 61607 FAX (309) 282-7546</p>	
<p>THIS DOCUMENT CONTAINS PROPRIETARY INFORMATION OF ALTORFER, INC. WITHOUT THE WRITTEN PERMISSION OF ALTORFER, INC., ANY COPYING OR OTHER USE, EXCEPT THAT FOR WHICH IT WAS INTENDED IS PROHIBITED.</p>			
<p>ALL DIMENSIONS IN INCHES UNLESS OTHERWISE SPECIFIED</p>		<p>PROJECT REFERENCE</p>	
<p>TOLERANCES: X.X ± 0.100 X.XX ± 0.060 X.XXX ± 0.005</p>		<p>FILE: DF54A SCALE/SHEET SIZE: 1=20/C DRAWN BY: K. NUNN DATE: 5/15/06</p>	
<p>THIRD ANGLE PROJECTION</p>		<p>QUOTE NUMBER</p>	
<p>ANGULAR ± 1'</p>		<p>WORK ORDER NUMBER</p>	
<p>TITLE: XQ400A/APS400A ENGINE EXHAUST GROUP</p>		<p>DRAWING NUMBER: 54A220-1</p>	