

| COMP | QTY | DESCRIPTION               | WEIGHT |
|------|-----|---------------------------|--------|
| 1    | 1   | 51E119-1 - S.H. WRNG HRNS | 1      |
| 2    | 1   | 13055 - 5/16-18x1.0 BOLT  | -      |
| 3    | 1   | 33006 - 5/16 FL WSHR      | -      |
| 4    | 1   | 33620 - 5/16 LCK WSHR     | -      |
| 5    | 2   | 4P-3829 - SAPCE HEATER    | 1      |

TOTAL 2

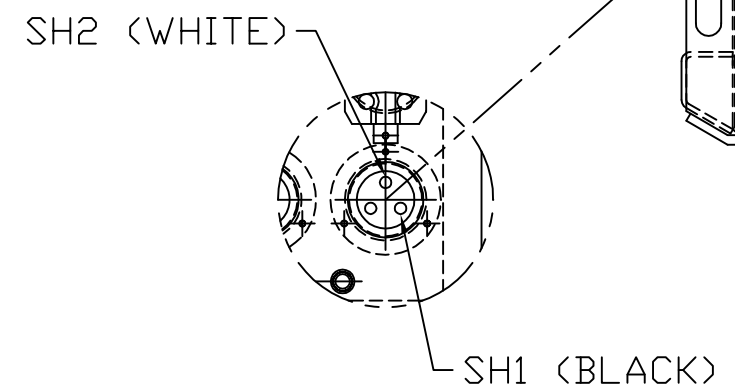
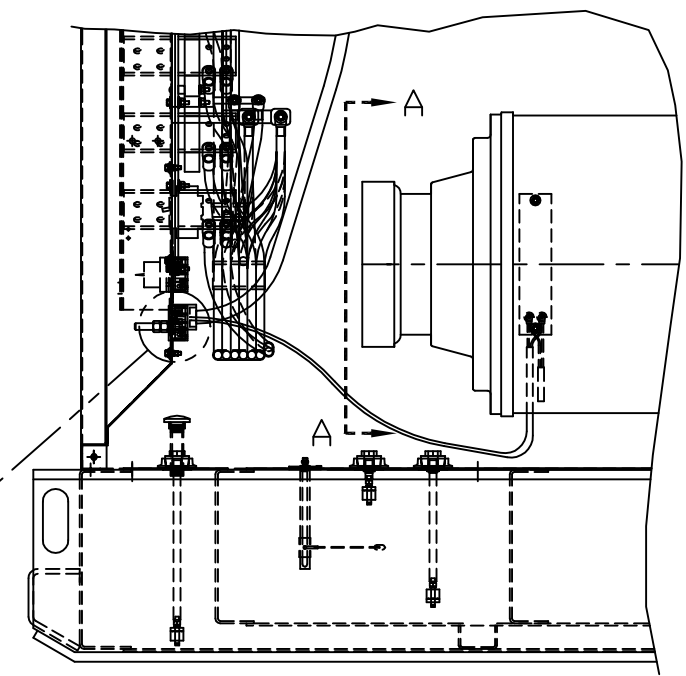
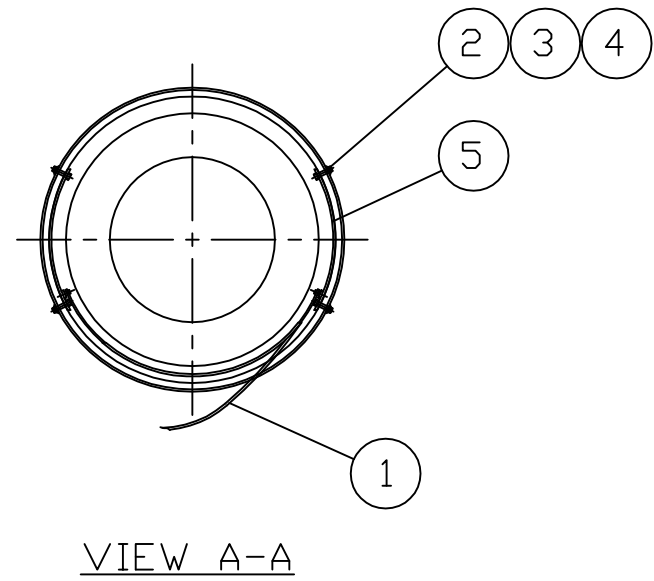

NOTE: TIE WRAP HARNESS TO MAIN LOAD CABLES AS NEEDED

DUAL VOLTAGE GENERATOR SPACE HEATER WIRING GROUP

|                              |  |                              |
|------------------------------|--|------------------------------|
| <b>ALTORFER</b><br>PACKAGING | <b>ALTORFER POWER SYSTEMS</b><br>#1 CAPITOL DRIVE P.O. BOX 2550 PH. 309-694-1234<br>EAST PEDRIA, IL. 61611-0550 FAX 309-694-1262 | <b>ALTORFER</b><br>PACKAGING |
|------------------------------|--|------------------------------|

|  |                       |    |      |              |            |
|--|-----------------------|----|------|--------------|------------|
|  |                       |    |      | JOB REF.     |            |
|  |                       |    |      | DRN BY       | QUOTE NO.  |
|  |                       |    |      | M. RANTA     |            |
|  |                       |    |      | DATE         | W/D NUMBER |
|  |                       |    |      | 12-19-00     |            |
|  |                       |    |      | SCALE        | FILE       |
|  |                       |    |      | 1=10         | DF51       |
| NO.  | DESCRIPTION OF CHANGE | BY | DATE | DRAWING NO.  |            |
| PROPRIETARY INFORMATION<br>UNAUTHORIZED DUPLICATION PROHIBITED |                       |    |      | SHEET 1 OF 1 |            |
|  |                       |    |      | 51A112       |            |