

ITEM	QTY.	DESCRIPTION
1	1	APS150 DUAL VOLTAGE GENERATOR SET
2	1	APS150 SOUND ATTENUATED ENCLOSURE GROUP
3	1	SINGLE POINT INTERNAL LIFT ARCH GROUP
4	2	HEAT SHIELD
5	1	5 Amp BATTERY CHARGER GROUP
6	1	3/4" NPT MAIN TANK VENT
7	1	BATTERY DISCONNECT SWITCH
8	1	STARTING BATTERY w/ RACK AND CABLE GROUP
9	1	10,000 Lb DROP SHOE HEAVY DUTY TONGUE JACK
10	1	16,000 Lb FULL STRUCTURAL FRAME TRAILER ASSEMBLY w/ ELEC/HYD BRAKES
11	1	3' ADJUSTABLE LUNETTE EYE
12	2	3/8" HEAVY DUTY SAFETY CHAIN w/ GRAB HOOK
13	1	3/4" NPT RUPTURE BASIN DRAIN
14	1	3/4" NPT MAIN TANK DRAIN
15	1	3/4" NPT EXTERNAL OIL DRAIN w/ INTERIOR VALVE
16	1	3/4" NPT EXTERNAL COOLANT DRAIN w/ INTERIOR VALVE
17	1	330 GAL ULI42 FUEL BASE ASSEMBLY
18	1	MECHANICAL TRAILER PARKING BRAKE
19	1	D.I.T. TRAILER LIGHT PACKAGE
20	1	EXTERNAL EMERGENCY STOP PUSH BUTTON
21	1	CRANKCASE FUMES DISPOSAL LINE GROUP
22	1	HINGED BATTERY ACCESS DOOR
23	1	5' CRITICAL GRADE EXHAUST SYSTEM w/ BLANKET AND RAIN CAP
24	1	7 PIN HEAVY DUTY TRAILER HARNESS PLUG
25	1	EMERGENCY BRAKE AWAY KIT w/ BATTERY AND CHARGER
26	1	2" NPT MANUAL FUEL FILL w/ CAP
27	1	1 1/2" NPT MECHANICAL FUEL LEVEL GAUGE
28	1	LOW FUEL LEVEL ALARM SWITCH
29	1	HIGH FUEL LEVEL ALARM SWITCH
30	1	FUEL LEVEL GAUGE SENDING UNIT w/ COVER
31	1	RUPTURE BASIN ALARM SWITCH
32	1	3/4" NPT RUPTURE BASIN VENT
33	1	HEAVY DUTY LICENSE PLATE BRACKET
34	1	EMC/PII CONTROL PANEL w/ ALARM MODULE AND ELECTRIC FUEL GAUGE
35	1	OPERATION DOCUMENT STORAGE BOX
36	1	DUAL VOLTAGE MAIN LOAD CONNECTION BUS ASSEMBLY
37	1	HINGED LOAD COVER DOOR w/ PLEXIGLASS WINDOW
38	1	1/2" NC BRONZE GROUNDING STUD w/ WASHERS AND NUTS
39	1	LOAD DOOR SAFETY TRIP SWITCH
40	1	CHANGE - OVER BOARD
41	1	12VDC SHUNT TRIP
42	1	PLEXIGLASS CONTROL PANEL WINDOW w/ WEATHER SEAL
43	1	15 Amp 120V BRANCH CIRCUIT BREAKER
44	2	15 Amp 120V GFI DUPLEX RECEPTACLE
45	1	20 Amp 120V BRANCH CIRCUIT BREAKER
46	2	20 Amp 120V GROUND FAULT INTERRUPTER
47	2	20 Amp 120V TWISTLOCK RECEPTACLE
48	1	20 Amp 240V BRANCH CIRCUIT BREAKER
49	1	20 Amp 240V TWISTLOCK RECEPTACLE
50	1	50 Amp 240V BRANCH CIRCUIT BREAKER
51	1	50 Amp 240V TWISTLOCK RECEPTACLE
52	1	30 Amp 125V TWISTLOCK JACKET WATER HEATER PLUG
53	1	30 Amp 125V TWISTLOCK BATTERY CHARGER AND GENERATOR HEATER PLUG
54	2	AUTO START/STOP CONTACT TERMINAL
55	8	DOOR KEEP ASSEMBLY
56	7	PERSONEL SAFETY GRAB HANDLE
57	2	PADLOCKABLE DOOR SLAM LATCH
58	2	ELECTRICAL ACCESS WEATHER FLAP
59	1	10,000 Lb TRAILER TIE DOWN RING
60	1	UL 142 CERTIFICATION LABEL
61	2	2" EMERGENCY TANK VENTS
62	2	2" EMERGENCY RUPTURE BASIN TANK VENTS

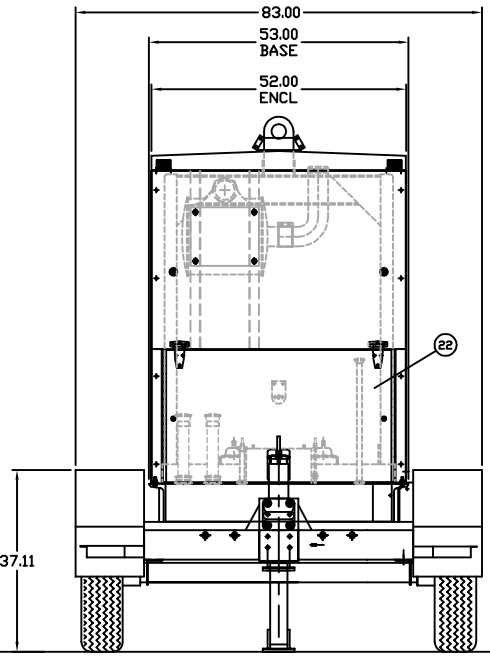

PACKAGE WEIGHTS:
 GENERATOR SET PACKAGE w/o TRAILER NO FUEL: 7,860 Lbs
 GENERATOR SET PACKAGE w/o TRAILER FULL FUEL: 10,110 Lbs
 GEN SET w/ TRAILER & NO FUEL: 10,850 Lbs
 GEN SET w/ TRAILER & FULL FUEL: 13,100 Lbs

DATE BY		ALTORFER		6315 W. FAUBER RD. PHONE (309) 697-1234 BARTONVILLE, IL 61607 FAX (309) 282-7546	
CHANGE NOTICE	THIS DOCUMENT CONTAINS PROPRIETARY INFORMATION OF ALTORFER, INC. WITHOUT THE WRITTEN PERMISSION OF ALTORFER, INC. ANY COPYING OR OTHER USE EXCEPT THAT FOR WHICH IT WAS INTENDED IS PROHIBITED UNLESS OTHERWISE SPECIFIED	FILE	DF/49A	PROJECT REFERENCE	APS150A RENTAL PACKAGE
	TOLERANCES: XX ± 0.100 ANGLE X.XX ± 0.060 X.XXX ± 0.005	THIRD PROJECTION	SCALE/SHEET SIZE	DRAWN BY	QUOTE NUMBER
	ANGULAR ± 1'		SHEET	DATE	WORK ORDER NUMBER
	TITLE		1 OF 1	02-10-12	
ALTORFER	APS150A RENTAL PACKAGE GENERAL DIMENSION				DRAWING NUMBER 49A201