

INCH 49A102

ITEM	QTY.	PART NO.	DESCRIPTION	WEIGHT
1	1	49A100	APS150 DUAL VOLTAGE ARRANGEMENT W/D FUEL W/ FUEL	10,980
2	1	49A117	APS150 TRAILER GROUP	13,840
3	1	49A118	APS150 TRAILER MOUNTING GROUP	2,750

TOTAL PACKAGE WEIGHTS:
 GENERATOR SET W/ TRAILER & NO FUEL= 10,950 lbs.
 GENERATOR SET W/ TRAILER & FUEL LOAD= 13,100 lbs.

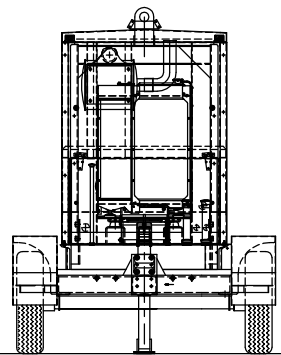
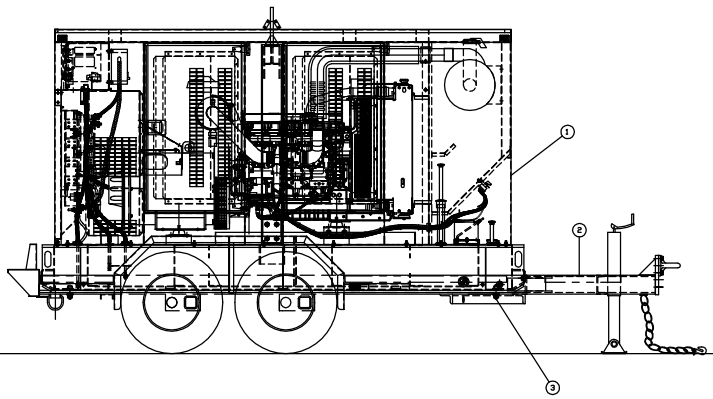
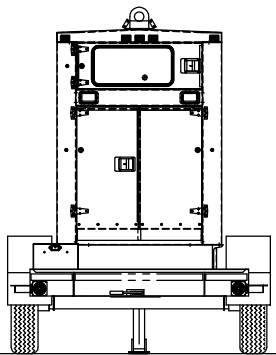
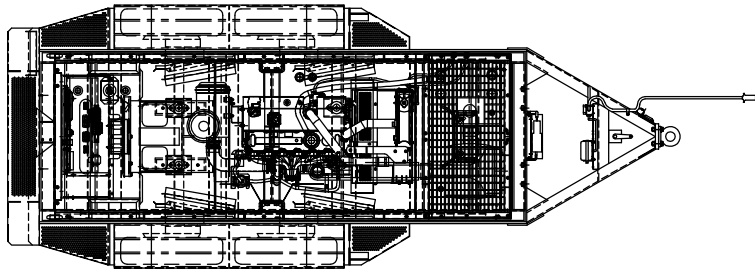

		ALTORFER POWER SYSTEMS 6315 N. FAUBER RD. PHONE (309) 697-1234 BARTONVILLE, IL 61807 FAX (309) 282-7546		
		THIS DOCUMENT CONTAINS PROPRIETARY INFORMATION OF ALTORFER, INC. WITHOUT THE WRITTEN PERMISSION OF ALTORFER, INC., ANY COPYING OR OTHER USE EXCEPT THAT FOR WHICH IT WAS INTENDED IS PROHIBITED.		
CHANGE NOTICE DATE:	ALL DIMENSIONS IN INCHES UNLESS OTHERWISE SPECIFIED	FILE: DF 49A	PROJECT REFERENCE: APS150 RENTAL PACKAGE	
	TOLERANCES: THIRD ANGLE PROJECTION XX & 0.100 XXX & 0.040 XXXX & 0.005	SCALE/SHEET SIZE: 1=20/D	DRAWN BY: B. LOHNES	QUOTE NUMBER: -
	ANGULAR ± 1'	SHEET: 1 OF 1	DATE: 02-19-09	WORK ORDER NUMBER: -
	TITLE: APS150 DUAL VOLTAGE RENTAL PACKAGE ARR. W/ TRAILER		DRAWING NUMBER: 49A102	