

ITEM	QTY.	DESCRIPTION
1	1	EMCP 4.2 CONTROL PANEL ARRANGEMENT
2	1	GENERATOR ARRANGEMENT
3	1	AIR CLEANER ARRANGEMENT
4	1	C4.4 BASIC ENGINE ARRANGEMENT
5	1	OPEN CRANK CASE VENT (FUMES DISPOSAL GROUP)
6	1	FUEL PRIMING PUMP
7	1	ENGINE OIL CAP AND DIPSTICK
8	1	RADIATOR CAP
9	1	EXHAUST SILENCER, PIPE, & ELBOW ASSEMBLY
10	1	MODULAR ARRANGEMENT (COMBUSTION EMISSIONS MODULE)
11	1	TRAILER TONGUE
12	1	STARTER
13	1	12V BATTERY ASSEMBLY
14	5	DOOR KEEP
15	2	GRAB HANDLE
16	7	PADLOCKABLE DOOR HANDLE
17	1	EMERGENCY STOP BUTTON EXTENSION
18	1	ENCLOSURE ASSEMBLY
19	1	SINGLE POINT LIFT-EYE
20	1	RAIN SKIRT
21	1	ANTENNA ASSEMBLY (GPS/CELLULAR)
22	1	FUEL TANK 150 GALLON CAPACITY (UL142/ULC-S601/UN314 CERTIFIED)
23	4	D-RING TIE DOWN
24	1	OIL MAKE UP TANK 2 GALLON CAPACITY (OPTIONAL)
25	1	REMOTE FUEL TANK SUPPLY - 3/4"NPT
26	1	REMOTE FUEL TANK RETURN - 3/4"NPT
27	4	SPILL CONTAINMENT DRAIN - 1/2" NPT
28	1	ENGINE OIL DRAIN - 3/4"NPT
29	1	RADIATOR COOLANT DRAIN - 3/4"NPT
30	1	BATTERY CHARGER
31	1	FUEL LINES - 3 WAY VALVE
32	1	TRAILER LEVELING JACK
33	1	FUEL COOLER
34	1	LOAD PAN GROUNDING STUD
35	1	SHUNT TRIP SWITCH
36	4	LOAD BUS BAR
37	1	DOCUMENT STORAGE BOX
38	1	ANNUNCIATOR PANEL LEGEND
39	1	ACKNOWLEDGE INDICATOR
40	1	HORN BUTTON
41	1	NAVIGATION BUTTON
42	1	NAVIGATION BUTTON
43	1	NAVIGATION BUTTON
44	1	RUN COMMAND BUTTON
45	1	ESCAPE COMMAND BUTTON
46	1	NAVIGATION SELECTOR BUTTON
47	1	AUTO MODE COMMAND BUTTON
48	1	STOP COMMAND BUTTON
49	1	EMERGENCY STOP BUTTON
50	1	ACKNOWLEDGE SELECTOR BUTTON
51	1	LED DISPLAY
52	1	HERTZ SELECTOR SWITCH
53	1	LAMP TEST INDICATOR LIGHT
54	1	VOLTAGE SELECTOR SWITCH
55	1	RESET BUTTON
56	1	PANEL LIGHT SWITCH
57	1	EVENT LOG BUTTON
58	1	MAIN ENGINE HARNESS ASSEMBLY
59	1	D.C. ALTERNATOR 105 AMP CIRCUIT BREAKER
60	1	D.C. MAIN FEED 105 AMP CIRCUIT BREAKER
61	1	D.C. ON/OFF SWITCH
62	1	JACKET WATER HEATER (120V W ISOLATION VALVE)
63	1	ENGINE D.C. ALTERNATOR
64	1	QUAD VOLTAGE CHANGE OVER SWITCH

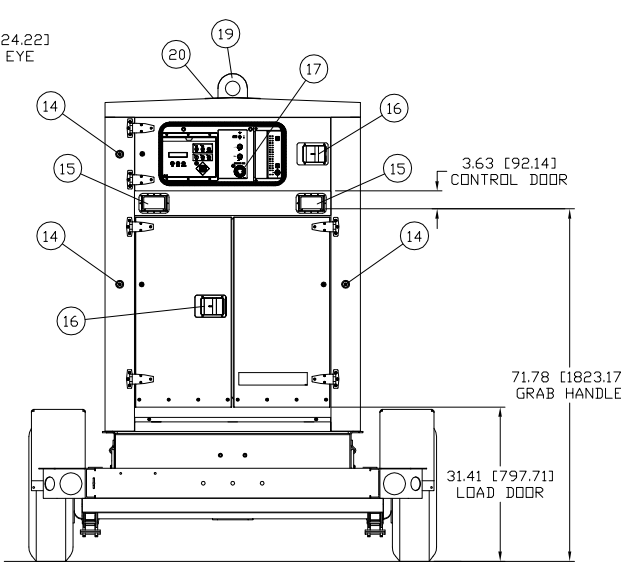
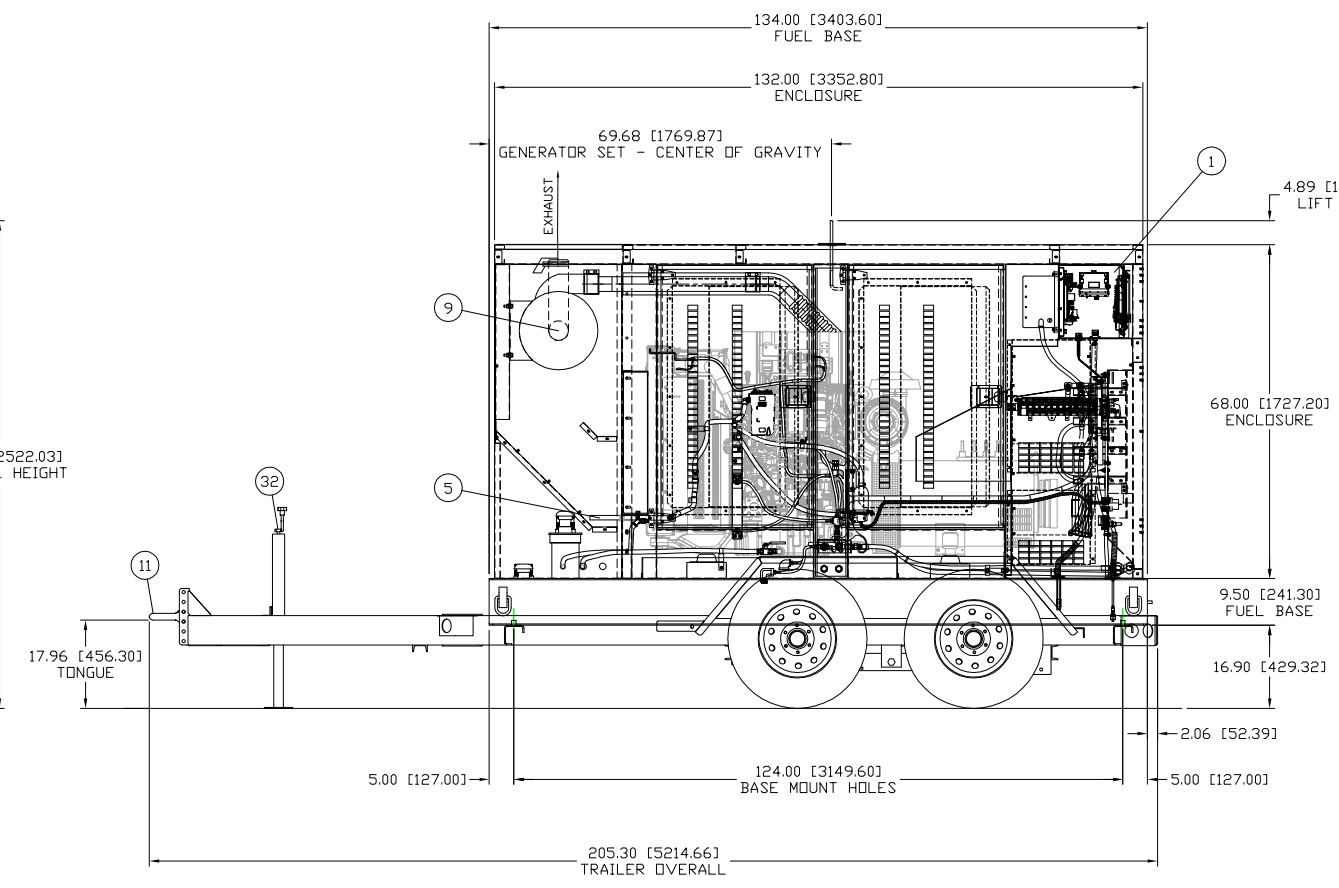
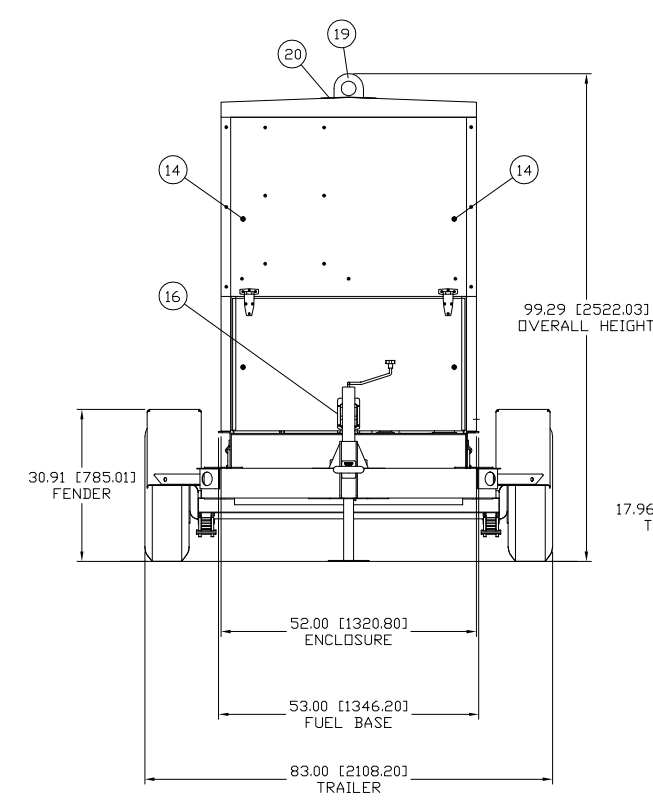

APS60 PACKAGE WEIGHTS:

GENERATOR SET PACKAGE NO FUEL: 5,855 Lbs
 GENERATOR SET PACKAGE FULL FUEL: 6,980 Lbs
 GENERATOR SET PACKAGE W/ TRAILER NO FUEL: 7,295 Lbs
 GENERATOR SET PACKAGE W/ TRAILER FULL FUEL: 8,420 Lbs

APS100 PACKAGE WEIGHTS:

GENERATOR SET PACKAGE NO FUEL: 6,370 Lbs
 GENERATOR SET PACKAGE FULL FUEL: 7,495 Lbs
 GENERATOR SET PACKAGE W/ TRAILER NO FUEL: 7,810 Lbs
 GENERATOR SET PACKAGE W/ TRAILER FULL FUEL: 8,935 Lbs

TRAILER INFORMATION:

GROSS VEHICLE WEIGHT RATING (GVWR): 9,980 lbs
 GROSS AXLE WEIGHT RATING (GAWR): 5,080 lbs
 THE WEIGHT OF CARGO SHOULD NEVER EXCEED 8,500 lbs

CONNECTION LEDGER

A - ENGINE FUEL SUPPLY - 3/4" NPT
 B - ENGINE FUEL RETURN - 1/2" NPT
 C - FUEL FILL - 2" NPT
 D - SIGHT LEVEL GAUGE - 1-1/2" NPT
 E - ELECTRIC FUEL LEVEL SENDER
 F - RUPTURE ALARM - 1-1/2" NPT
 G - ATMOSPHERIC MAIN TANK VENT - 5" NPT
 H - EMERGENCY VENT - 3" NPT
 I - NORMAL WORKING VENT - 2" NPT
 J - MAIN TANK DRAIN - 3/4" NPT

DATE		ALTORFER		ALTORFER POWER SYSTEMS	
BY		8315 W. FAUBER RD.		PHONE (309) 697-1234	
		BARTONVILLE, IL 61607		FAX (309) 282-7546	
CHANGE NOTICE	FILE	PROJECT REFERENCE	THIS DOCUMENT CONTAINS PROPRIETARY INFORMATION OF ALTORFER, INC. WITHOUT THE WRITTEN PERMISSION OF ALTORFER, INC., ANY COPYING OR OTHER USE EXCEPT THAT FOR WHICH IT WAS INTENDED IS PROHIBITED.		
	DF/47	APS60/100 RENTAL PACKAGE	ALL DIMENSIONS IN INCHES UNLESS OTHERWISE SPECIFIED		
	THIRD ANGLE PROJECTION	DRAWN BY BML	TOLERANCES: XX ± 0.100	SCALE/SHEET SIZE I=20/D	QUOTE NUMBER
	SHEET 1 OF 2	DATE 05/14/14	X.XX ± 0.050		WORK ORDER NUMBER
TITLE	APS60/100 GENERAL DIMENSION			DRAWING NUMBER 47A104A	

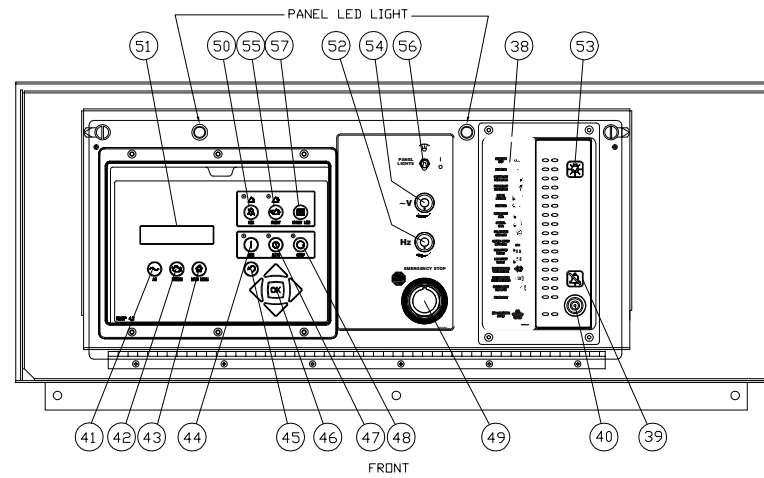
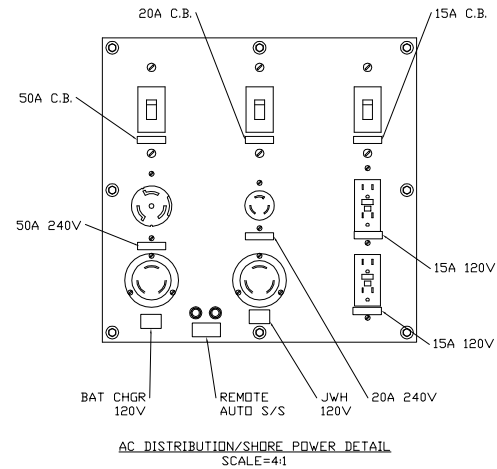
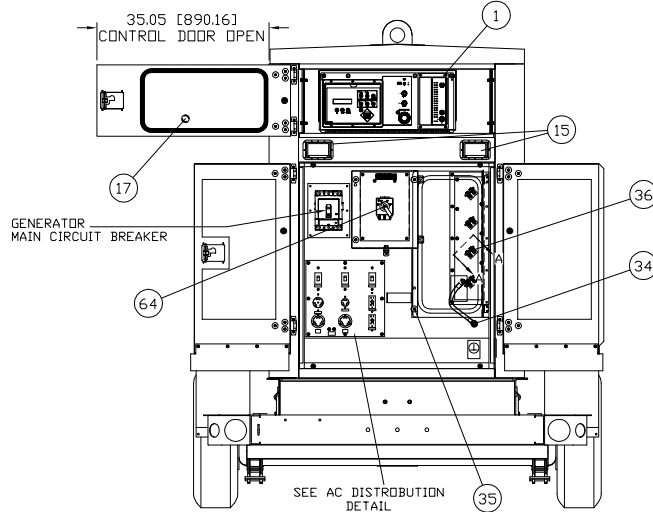
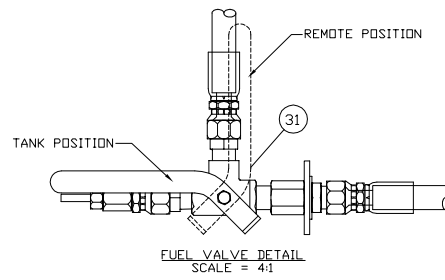
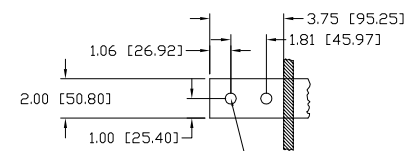
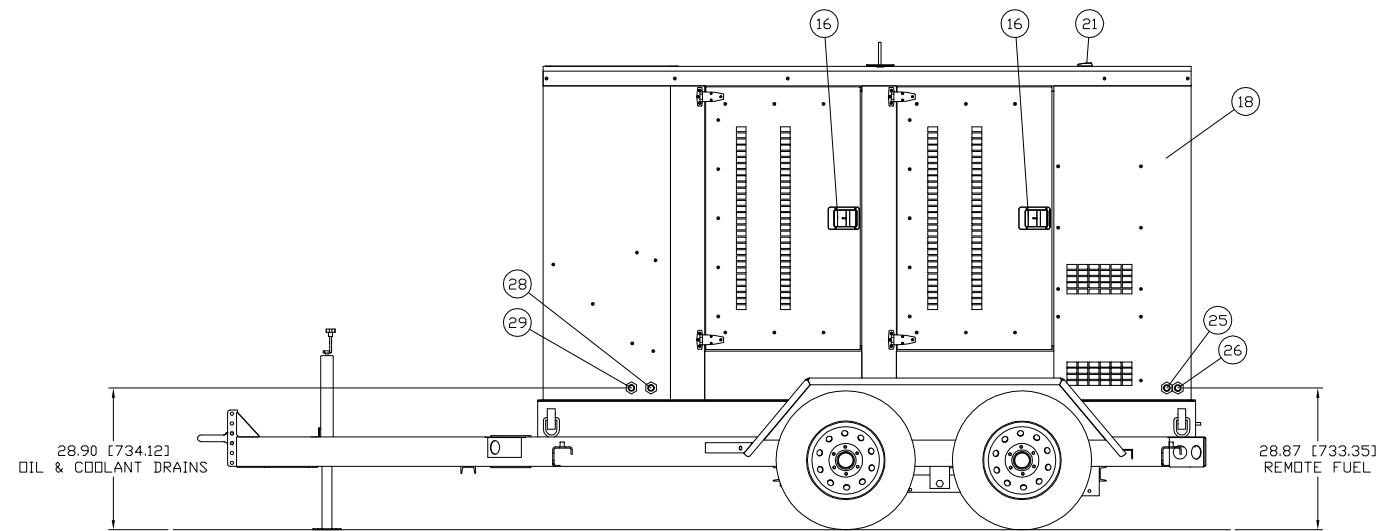
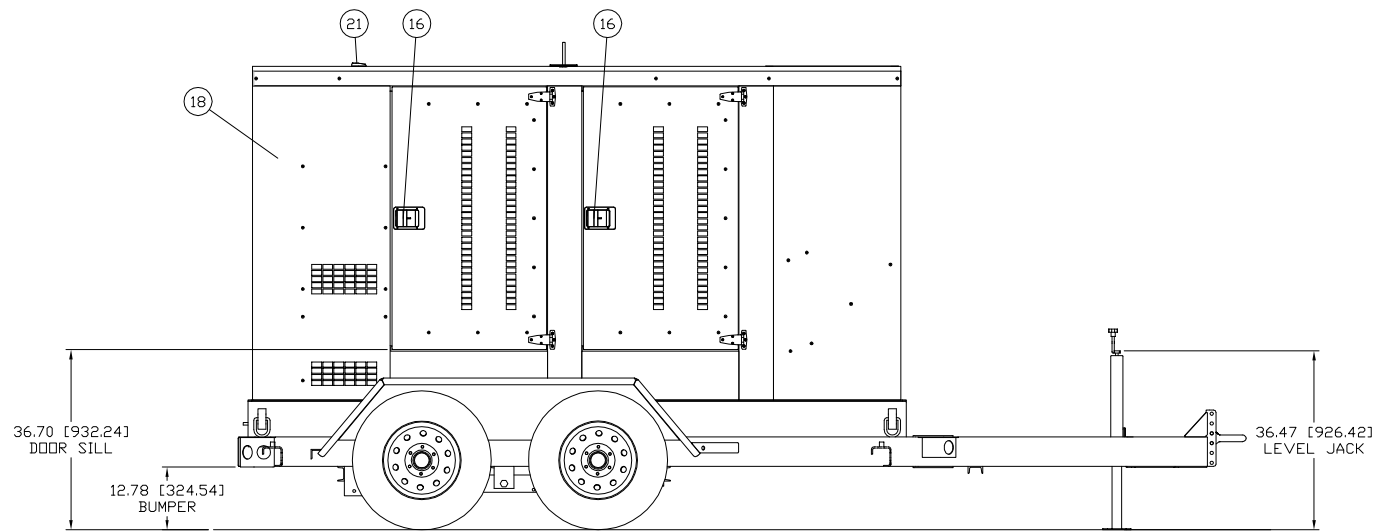
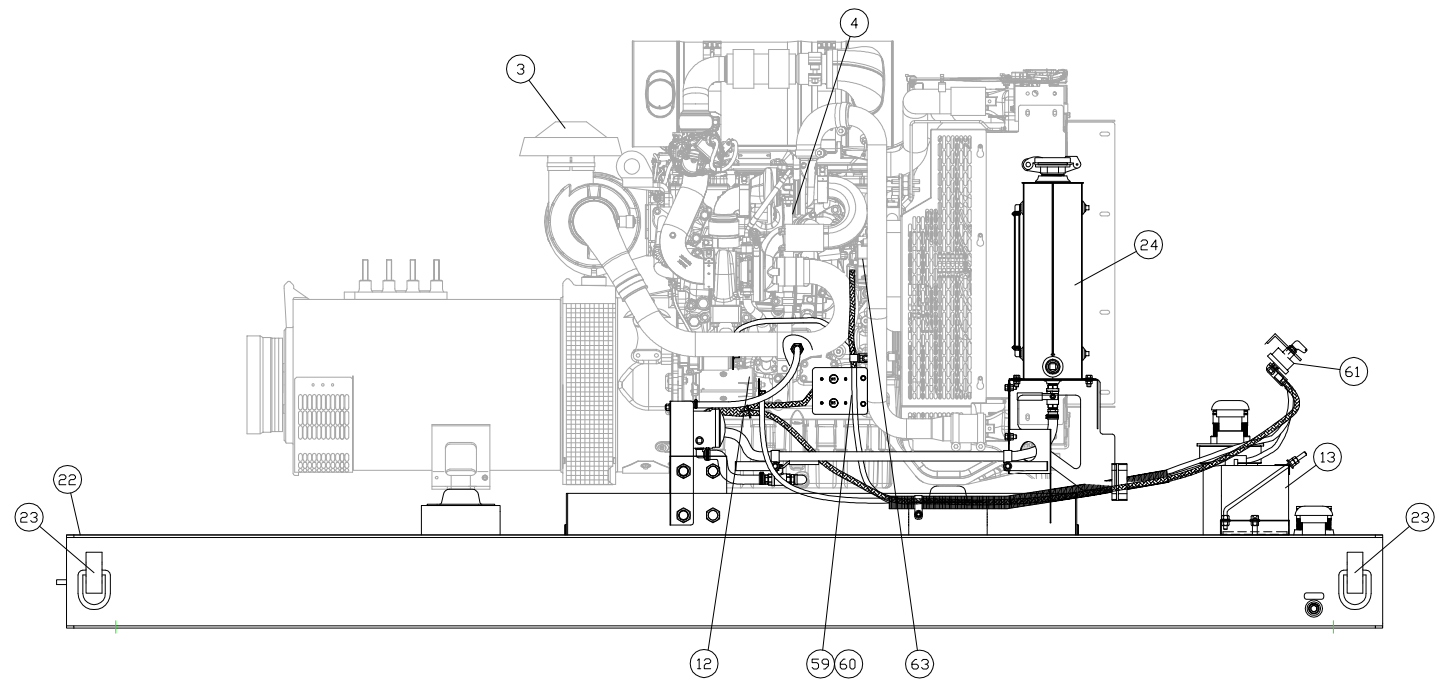
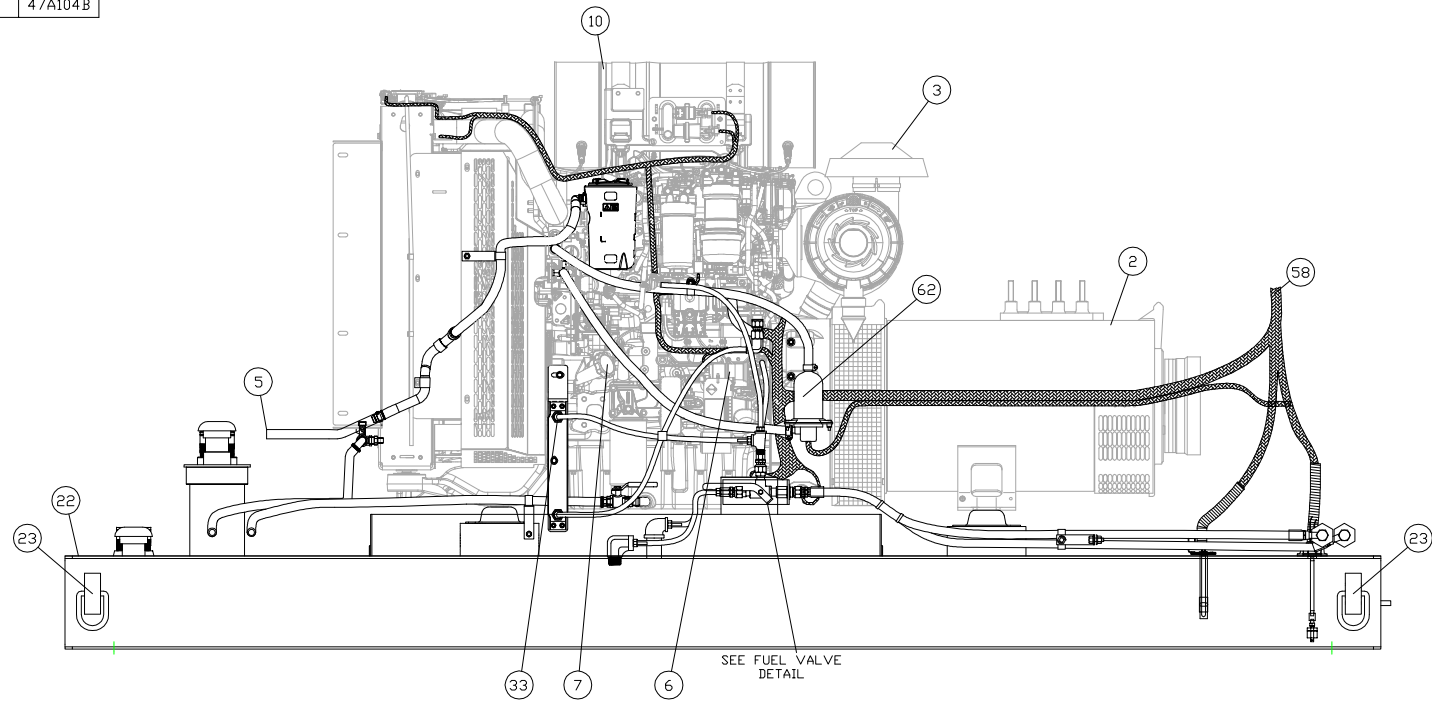

EMCP 4.2 DETAIL
SCALE=4:1

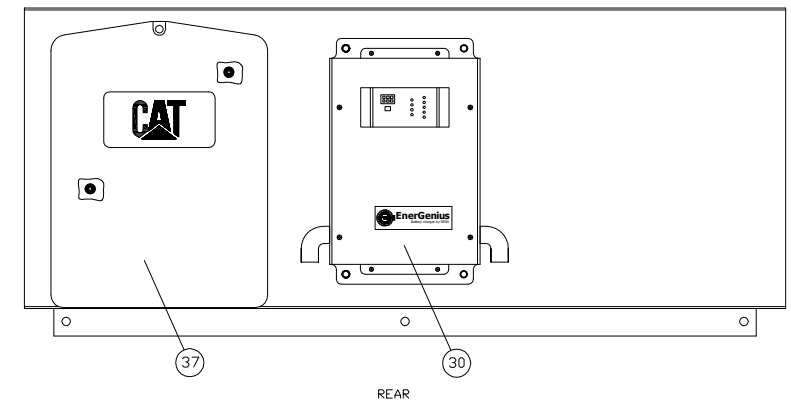

DATE BY		ALTORFER		ALTORFER POWER SYSTEMS	
		6315 W. FAUBER RD.		PHONE (309) 697-1234	
		BARTONVILLE, IL 61607		FAX (309) 282-7546	
THIS DOCUMENT CONTAINS PROPRIETARY INFORMATION OF ALTORFER, INC. WITHOUT THE WRITTEN PERMISSION OF ALTORFER, INC. ANY COPYING OR OTHER USE EXCEPT THAT FOR WHICH IT WAS INTENDED IS PROHIBITED.		FILE		PROJECT REFERENCE	
ALL DIMENSIONS IN INCHES UNLESS OTHERWISE SPECIFIED		DF/47		APS60/100 RENTAL PACKAGE	
TOLERANCES:		THIRD ANGLE PROJECTION		DRAWN BY	
X.X ± 0.100		SCALE/SHEET SIZE		BML	
X.XX ± 0.050		1=20/D		DATE	
X.XXX ± 0.005		SHEET		05/14/14	
ANGULAR ± 1'		2 OF 2		WORK ORDER NUMBER	
TITLE		APS60/100 GENERAL DIMENSION		DRAWING NUMBER	
				47A104B	