

| | | | | | |
|--|--|---|--|--|--|
| ADD PREP. TIME & COSTS FOR WELDING CONNECTORS & TERMINALS IN BILLING SHEET CHANGE NOTICE DATE BY | | ALTORFER | | ALTORFER POWER SYSTEMS 6315 W. FAUBER RD. PHONE (309) 697-1234 BARTONVILLE, IL 61607 FAX (309) 282-7546 | |
| | | THIS DOCUMENT CONTAINS PROPRIETARY INFORMATION OF ALTORFER, INC. WITHOUT THE WRITTEN PERMISSION OF ALTORFER, INC., ANY COPYING OR OTHER USE EXCEPT THAT FOR WHICH IT WAS INTENDED IS PROHIBITED | | ALL DIMENSIONS IN INCHES UNLESS OTHERWISE SPECIFIED | |
| FILE: DF/54E | | PROJECT REFERENCE: XQ400 (3456) RENTAL UNIT | | DRAWN BY: D. ROLING | |
| TOLERANCES: X.X ± 0.100 X.XX ± 0.050 X.XXX ± 0.005 | | SCALE/SHEET SIZE: 1=1/D | | QUOTE NUMBER: - | |
| THIRD ANGLE PROJECTION | | SHEET: 1 OF 3 | | DATE: 12/01/2015 | |
| ANGULAR ± 1° | | TITLE: XQ400RH (3456) CONTRL. PANEL GRPUP | | WORK ORDER NUMBER: - | |
| DRAWING NUMBER: 54A415-01 | | | | | |

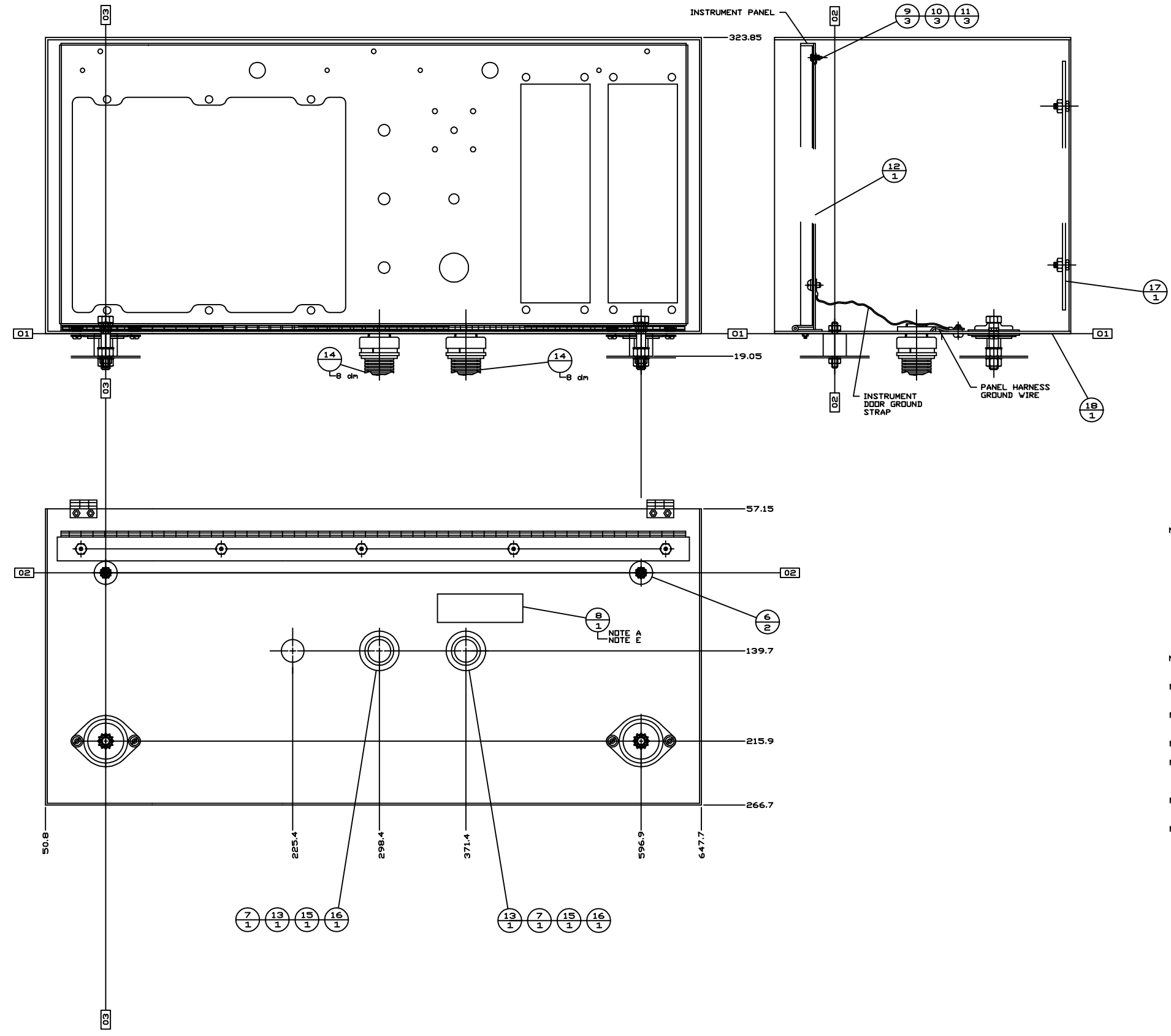

| ITEM | QTY | MEAS UNIT | PART NO. | NAME |
|----------|-----|-----------|----------|-----------|
| MISC REF | | | | |
| 1 | | | | |
| 2 | | | | |
| 3 | | | | |
| 4 | | | | |
| 5 | | | | |
| 6 | 2 | | 7C-6121 | MOUNT |
| 7 | 2 | | 5N-9067 | COLLAR |
| 8 | 1 | | 9Y-9771 | FILM |
| 9 | 3 | | 4P-2160 | WASHER |
| 10 | 3 | | 4P-2161 | SCREW |
| 11 | 3 | | 4P-2162 | CLIP |
| 12 | 1 | | 104-7287 | PANEL AS. |
| 13 | 2 | | 5N-9072 | CLIP |
| 14 | 16 | dm | 5N-8359 | CONDUIT |
| 15 | 2 | | 5N-9117 | ADAPTER |
| 16 | 2 | | 062-5388 | LOCKNUT |
| 17 | 1 | | 204-9551 | PANEL AS. |
| 18 | 1 | | 204-0747 | BOX AS. |

NOTE: REFERENCE CAT DRAWING# 194-7764-03 SHEET 2 FOR BILL OF MATERIALS.

- NOTE A: MOUNT FILMS ON CONTROL PANEL FLOOR.
- NOTE B: FRONT PANEL TO BE 14 GA HINGED AT BOTTOM. BOLT OR PIN SECURE AT THE TOP.
- NOTE C: COMPLETE CONTROL PANEL SHALL BE FINISH PAINTED CATERPILLAR YELLOW, INSTRUMENT DOOR SHALL BE PAINTED FLAT BLACK.
- NOTE D: CONTROL PANEL BOX TO BE 14 GA. FORMED CONSTRUCTION.
- NOTE E: IDENTIFICATION NAME PLATE SHALL BE PERMANENTLY AFFIXED TO THE INSIDE LOWER SURFACE OF THE CONTROL PANEL ENCLOSURE & SHALL INCLUDE THE PANEL PART NUMBER, MODEL NUMBER & DATE CODE OF MANUFACTURE.
- NOTE F: A COMPLETE SET OF CATERPILLAR DRAWINGS SHALL BE PACKED INSIDE EACH CONTROL PANEL.
- NOTE G: CONTROL PANEL ENCLOSURE JOINTS & HARDWARE MOUNTING HOLES SHALL BE SEALED WITH DOW CORNING RTV732.

| | | | |
|---|------------------------|--|----------------------------|
| ALTORFER | | ALTORFER POWER SYSTEMS | |
| 6315 W. FAUBER RD. BARTONVILLE, IL 61607 | | PHONE (309) 697-1234 FAX (309) 282-7546 | |
| THIS DOCUMENT CONTAINS PROPRIETARY INFORMATION OF ALTORFER, INC. WITHOUT THE WRITTEN PERMISSION OF ALTORFER, INC. ANY COPYING OR OTHER USE EXCEPT THAT FOR WHICH IT WAS INTENDED IS PROHIBITED. | | | |
| ALL DIMENSIONS IN INCHES UNLESS OTHERWISE SPECIFIED | FILE | PROJECT REFERENCE | |
| TOLERANCES: X.X ± 0.100 X.XX ± 0.050 X.XXX ± 0.005 | THIRD ANGLE PROJECTION | DF/54E | XQ400RM (3456) RENTAL UNIT |
| ANGULAR ± 1° | SHEET | DRAWN BY | QUOTE NUMBER |
| | 2 OF 3 | D. ROLING | - |
| | | DATE | WORK ORDER NUMBER |
| | | 12/01/2015 | - |
| TITLE | | | DRAWING NUMBER |
| XQ400RM (3456) CONTROL PANEL GROUP | | | 54A415-01 |

